

SERVICE MANUAL

PARTS LIST

AKAI STEREO TAPE DECK

MODEL **GX-4000**

ALSO APPLICABLE TO MODEL GX-4000-PRO

pages 2, 51, 52, 92 are blank and not included

pages 2, 51, 52, 92 are blank and not included



STEREO TAPE DECK

MODEL GX-400D

ALSO APPLICABLE TO MODEL GX-400D-PRO
STEREO TAPE DECK

SECTION 1	SERVICE MANUAL	3
SECTION 2	PARTS LIST	53
SECTION 3	CONNECTION DIAGRAM	91
SECTION 4	SCHEMATIC DIAGRAM	

I. SPECIFICATIONS

1. MODEL: GX-400D

An asterisk next to a figure indicates the minimum guaranteed performance.

TRACK SYSTEM		4 track 2 channel stereo, monaural Recording/Playback
TAPE SPEED		15, 7-1/2 and 3-3/4 ips. $\pm 0.5\%$ (*1.5%)
WOW AND FLUTTER		Less than 0.035%(*0.06%) R.M.S. at 15 ips. Less than 0.05%(*0.09%) R.M.S. at 7-1/2 ips. Less than 0.08%(*0.15%) R.M.S. at 7-1/2 ips.
FREQUENCY RESPONSE	S.R.T. Tape	20 to 30,000 Hz(*30 to 27,000 Hz ± 3 dB) at 15 ips. 20 to 28,000 Hz(*30 to 24,000 Hz ± 3 dB) at 7-1/2 ips. 30 to 20,000 Hz(*30 to 17,000 Hz ± 3 dB) at 3-3/4 ips.
	Normal Tape	20 to 28,000 Hz(*30 to 24,000 Hz ± 3 dB) at 15 ips. 20 to 26,000 Hz(*30 to 22,000 Hz ± 3 dB) at 7-1/2 ips. 30 to 19,000 Hz(*30 to 15,000 Hz ± 3 dB) at 3-3/4 ips.
DISTORTION		*Less than 2% at 15 ips. 1,000 Hz "0" VU recording *Less than 2% at 7-1/2 ips. 1,000 Hz "0" VU recording *Less than 3% at 3-3/4 ips. 1,000 Hz "0" VU recording
OUTPUTS	Line Output Din Output Head Phone Output	0 \pm 1 dB(O VU), 6 \pm 1.5 dB(VR Max.) 390 mV 50 \pm 10 mV 8 Ω load 1,000 Hz O VU Head Phone Volume maximum
INPUTS	Mic Input Line Input Din Input	0.7 mV 70 mV 15 mV(low), 300 mV(high)
RECORDING/PLAYBACK LEVEL		0 \pm 1.5 dB
SIGNAL TO NOISE RATIO		Better than 54 dB(*48 dB)
CROSS TALK	Stereo Monaural	*Better than 45 dB at 1,000 Hz 3 VU recording Better than 70 dB *Better than 60 dB at 1,000 Hz 3 VU recording
ERASE RATIO		Better than 70 dB
RECORDING BIAS FREQUENCY		100 \pm 5 kHz
BIAS LEAK	Stereo Monaural	Less than -30 VU Less than -20 VU
HIGH FREQUENCY DEVIATION		0 \pm 1.5 dB, using a 15,000 Hz test tape at 15 ips.
REVERSING TIME		Within 4 sec. at 15 ips. Within 3 sec. at 7-1/2, 3-3/4 ips.
RECORDING CAPACITY		90 min. stereo recording, using a 3,600 ft. tape at 15 ips.
F.FWD AND RWD TIME		120/100 sec., using a 2,400 ft. tape at 50/60 Hz
MOTORS	Capstan Motor Reel Motor	4 pole eddy current A.C. servo motor Type: SCM3-16TW Revolutions: 800 r.p.m. at 15 ips. 400 r.p.m. at 7-1/2 ips. 200 r.p.m. at 3-3/4 ips. Two 6 pole eddy current inner rotor motors Type: IM1-24TW Revolutions: 1,000/1,200 r.p.m. at 50/60 Hz
HEADS	Combo Recording/ Erase Head Playback Head	Type: RE4-6 Gap: 3.5 to 5.5 microns(Rec.) 0.2 mm x 2 W Gap(Erase) Impedance: 1,400 Ω \pm 25% at 100 kHz(Rec.) 130 Ω \pm 7% at 100 kHz(Erase) D.C. Resistance: 5.5 Ω Rec.(approx.) 2.3 Ω Erase(approx.) Type: P4-220 Gap: 0.5 to 2 microns Impedance: 1.2 k Ω \pm 25% at 1 kHz D.C. Resistance: 160 Ω (approx.)

TRANSISTORS	2SA564(Q)(R) ... 3 2SA628(D)(F) ... 3 2SA640(L) ... 10 2SA733(R) ... 2 2SC458LG(C) ... 2 2SC711(D)(E) ... 32 2SC792 ... 1 2SC945(Q)(R) ... 8	2SC971 ... 1 2SC1014(C)(D) ... 1 2SC1098(L)(M) ... 2 2SC1211(C)(D) ... 1 2SC1222(E)(F) ... 12 2SC1247A(B)(V) ... 12 2SD234(O)(R) ... 1
F.E.T.	2SK30(O) ... 2	
DIODES	1N34A ... 4 WG713 ... 5 1S1588 ... 52 10D05 ... 9 10D1 ... 7	10D4 ... 7 10DC-2(Blk) ... 1 10DC-2(Red) ... 1 5B2 ... 1
ZENER DIODES	RD7A(L)(N) ... 3 RD9A ... 2	WZ085 ... 2
THERMISTER	31D26 ... 1	
POWER SUPPLY	100 to 240V.A.C. 50/60Hz	
POWER CONSUMPTION	160W maximum	
INSULATION RESISTANCE	More than 50 M Ω	
DIMENSIONS	457(W)x590(H)x240(D) mm (18"x23.2"x9.5")	
WEIGHT	31.2 kg(68.7 lbs.)	

NOTE: Specifications subject to change without notice.

2. MODEL: GX-400D-PRO

An asterisk next to a figure indicates the minimum guaranteed performance.

TRACK SYSTEM		2 track 2 channel stereo Recording/Playback 4 track 2 channel stereo Playback
TAPE SPEED		15, 7-1/2 and 3-3/4 ips. $\pm 1.5\%$
WOW AND FLUTTER		Less than 0.035% (*0.06%) R.M.S. at 15 ips. Less than 0.09% R.M.S. at 7-1/2 ips. Less than 0.15% R.M.S. at 3-3/4 ips.
FREQUENCY RESPONSE	S.R.T. Tape	30 to 27,000 Hz ± 3 dB at 15 ips. 30 to 24,000 Hz ± 3 dB at 7-1/2 ips. 30 to 18,000 Hz ± 3 dB at 3-3/4 ips.
	Normal Tape	30 to 24,000 Hz ± 3 dB at 15 ips. 30 to 22,000 Hz ± 3 dB at 7-1/2 ips. 30 to 16,000 Hz ± 3 dB at 3-3/4 ips.
DISTORTION		*Less than 2% at 15 ips. 1,000 Hz 0 VU recording *Less than 2% at 7-1/2 ips. 1,000 Hz 0 VU recording *Less than 3% at 3-3/4 ips. 1,000 Hz 0 VU recording
OUTPUTS	Line Output	0 \pm 1 dB (0 VU), 6 \pm 1.5 dB (VR Max.)
	Din Output	390 mV
	Head Phone Output	50 \pm 10 mV 8 Ω load 1,000 Hz 0 VU Head Phone Volume maximum
INPUTS	Mic Input	0.5 mV
	Line Input	50 mV
	Din Input	10 mV (low), 250 mV (high)
RECORDING PLAYBACK LEVEL		0 \pm 1.5 dB
SIGNAL TO NOISE RATIO	2 Track	Better than 58 dB *Better than 53 dB
	4 Track	*Better than 48 dB
CROSS TALK		Better than 45 dB (*43 dB) at 1,000 Hz 3VU recording
ERASE RATIO		Better than 70 dB
RECORDING BIAS FREQUENCY		160 \pm 10 kHz
BIAS LEAK		Less than -30 VU
HIGH FREQUENCY DEVIATION	2 Track	0 \pm 1.5 dB, using a 15,000 Hz test tape at 15 ips.
	4 Track	0 \pm 3 dB, using a 15,000 Hz test tape at 15 ips.
RECORDING CAPACITY		45 min. stereo recording, using a 3,600 ft. tape at 15 ips.
F. FWD AND RWD TIME		120/100 sec., using a 2,400 ft. tape at 50/60 Hz
MOTORS	Capstan Motor	4 pole eddy current A.C. servo motor Type: SCM3-16TW Revolutions: 800 r.p.m. at 15 ips. 400 r.p.m. at 7-1/2 ips. 200 r.p.m. at 3-3/4 ips.
	Reel Motor	Two 6 pole eddy current inner rotor motors Type: IM1-24TW Revolutions: 1,000/1,200 r.p.m. at 50/60 Hz
HEADS	Erase Head	Type EF-210 Gap: 0.2mm x 2 W Gap Impedance: 360 Ω \pm 10% at 100 kHz D.C. Resistance: 2.8 Ω (approx.)
	2 Track Recording Head	Type: R2-100 Gap: 4.5 \pm 1 microns Impedance: 3 k Ω \pm 20% at 100 kHz D.C. Resistance: 8 Ω (approx.)
	2 Track Playback Head	Type: P2-100 Gap: 0.5 to 1 microns Impedance: 1.9 k Ω \pm 20% at 1 kHz D.C. Resistance: 250 Ω (approx.)
	4 Track Playback Head	Type: P4-220 Gap: 0.5 to 2 microns Impedance: 1.2 k Ω \pm 25% at 1 kHz D.C. Resistance: 160 Ω (approx.)

TRANSISTORS	2SA564(Q)(R) ... 3 2SA628(D)(F) ... 2 2SA640(L) ... 10 2SA733(R) ... 2 2SC458LG(C) ... 2 2SC711(D)(E) ... 30 2SC792 ... 1 2SC945(Q)(R) ... 8	2SC971 ... 1 2SC1014(C)(D) ... 1 2SC1098(L)(M) ... 2 2SC1211(C)(D) ... 1 2SC1222(E)(F) ... 12 2SC1247A(B)(V) ... 10 2SD234(O)(R) ... 1
F.E.T.	2SK30(O) ... 2	
DIODES	1N34A ... 4 WG713 ... 5 1S1588 ... 36 10D05 ... 7 10D1 ... 7	10D4 ... 7 10DC-2(Blk) ... 1 10DC-2(Red) ... 1 5B2 ... 1
ZENER DIODES	RD7A(L)(N) ... 3 RD9A ... 2	WZO85 ... 3
THERMISTER	31D26 ... 1	
POWER SUPPLY	100 to 240V.A.C. 50/60 Hz	
POWER CONSUMPTION	160W maximum	
INSULATION RESISTANCE	More than 50 M Ω	
DIMENSIONS	457(W)x590(H)x258(D) mm (18"x23.2"x10.2")	
WEIGHT	30.5 kg(67.2 lbs.)	

NOTE: Specifications subject to change without notice.

II. MEASURING METHOD

1. TAPE SPEED DEVIATION

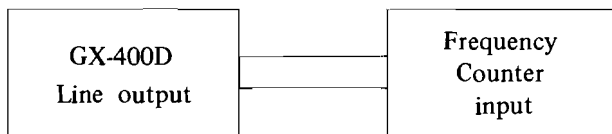

Fig. 1

As shown in Fig. 1, connect a Frequency Counter to the Line output of Model GX-400D. Playback a 1,000 Hz pre-recorded test tape. Take a Frequency Counter reading at the beginning, middle, and end of tape winding during playback. The maximum value of these respective readings will represent tape speed deviation.

2. WOW AND FLUTTER

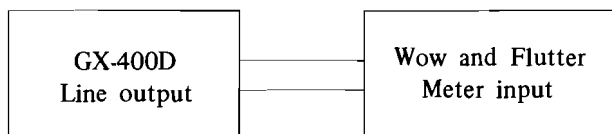

Fig. 2

Method A

As shown in Fig. 2, connect the Line output of Model GX-400D to the input of a Wow and Flutter Meter. Playback a 3,000 Hz pre-recorded test tape and take a Wow and Flutter Meter reading at the beginning, middle, and end of tape winding. The maximum value of these respective readings will represent the Wow and Flutter.

Method B

Supply a 3,000 Hz sine wave signal from an Audio Frequency Oscillator and make a recording on a blank tape at the beginning, middle, and end of tape winding. Rewind and playback the resultant signal. Measure Wow and Flutter with a Wow and Flutter Meter. (The Wow and Flutter value of Method B will be close to $\sqrt{2}$ times of value of Method A.)

3. FREQUENCY RESPONSE

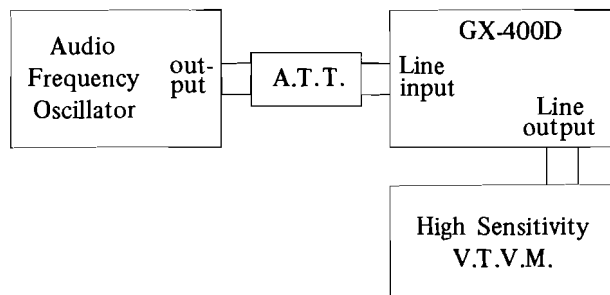

Fig. 3

For measuring Frequency Response, connect instruments as shown in Fig. 3 and proceed as follows:

- 1) Supply a 1,000 Hz sine wave signal to the Line input of Model GX-400D from an Audio Frequency Oscillator through an Attenuator.
- 2) Set recorder to recording mode and turn recording level control volume to maximum. Adjust Attenuator to obtain a 0 dB V.T.V.M. reading.
- 3) Under conditions described in 2) above, readjust Attenuator so that the Line output is -20 dB, and record 30 to 27,000 Hz spot frequencies.
- 4) Rewind tape and playback from the beginning. Take V.T.V.M. spot frequency readings and plot values on a graph.

NOTE: When measuring Frequency Response, new tape should be used.

4. SIGNAL TO NOISE RATIO

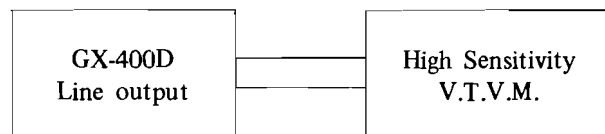

Fig. 4

As shown in Fig. 4, connect a High Sensitivity V.T.V.M. to the Line output of Model GX-400D. Playback a 700 Hz "0" VU pre-recorded test tape and measure the output. Then remove the tape and measure the noise level under the same condition. Convert each of the measured values into decibels.

5. TOTAL HARMONIC DISTORTION

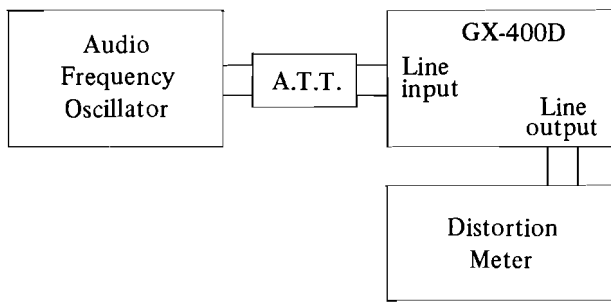

Fig. 5

Connect the measuring instruments as shown in Fig. 5 and record a 1,000 Hz sine wave signal at "0" VU. Playback the resultant signal and measure the overall distortion factor.

- NOTE: 1) At this time, Distortion of the Audio Frequency Oscillator must be sufficiently small.
2) When measuring the distortion factor, new tape should be used.

6. CROSS TALK (Cross talk between the tracks)

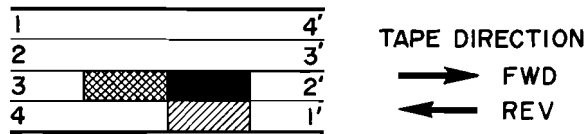

Fig. 6

As shown in Fig. 6 first record a 1,000 Hz sine wave signal on track No. 3 at +3 VU level. Next, record under a non-input condition. Then playback the tape on track No. 3 and 1' (reversed condition of tape) through the B.P.F. (1,000 Hz Band Pass Filter, sensitivity 1,000 Hz, ratio 1:1) and obtain the ratio from the following formula.

$$C = 20 \log \frac{E_0}{E_2 - E_1} \quad (\text{dB})$$

- where, C = Desired cross talk ratio (dB)
 E_0 = 1,000 Hz signal output level (V)
 E_2 = 1,000 Hz cross talk level (V)
 E_1 = Non-input cross talk level (V)

7. ERASE RATIO

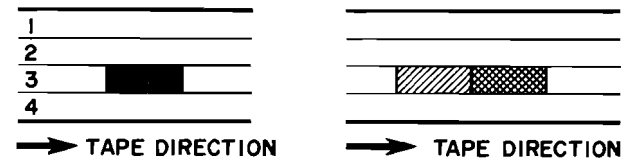

Fig. 7

As shown in Fig. 7 using a virgin tape first record a 1,000 Hz sine wave signal on track No. 3 at +3 VU level, then playback this recorded signal and take a V.T.V.M. reading at the output level. Next, erase this recorded portion and playback the erased part through the B.P.F. (1,000 Hz sensitivity 1:1) and take readings of the erased signal. Obtain a ratio between the two from the following formula:

$$E_r = 20 \log \frac{E_0}{E_2 - E_1} \quad (\text{dB})$$

- where, E_r = Desired erase ratio
 E_0 = 1,000 Hz signal output level (V)
 E_2 = Erased 1,000 Hz signal and noise level (V)
 E_1 = Erased noise level (V)

NOTE: When measuring cross talk and erase ratio virgin tape should be used.

III. DISMANTLING OF UNIT

In case of trouble, etc. necessitating disassembly, please disassemble in the order shown in photographs. Reassemble in reverse order.

1

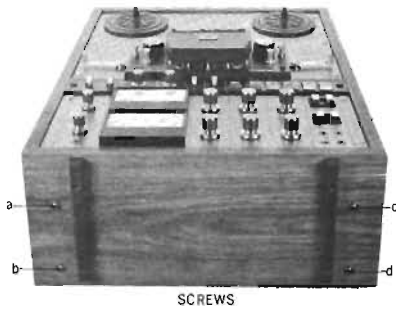

2

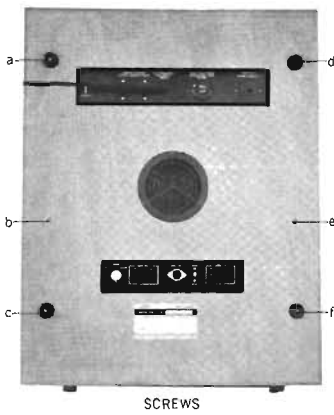

3



4

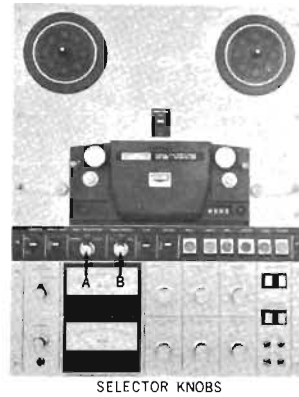

5



6

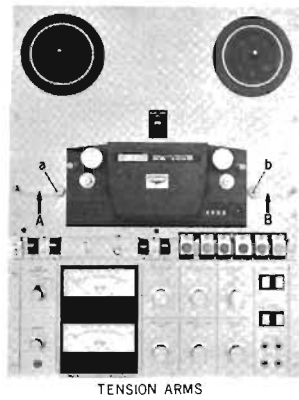

7

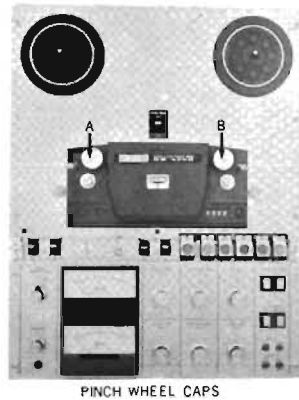

8

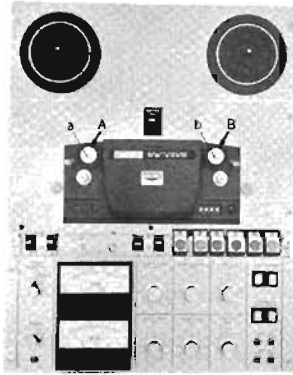

PINCH WHEELS

9

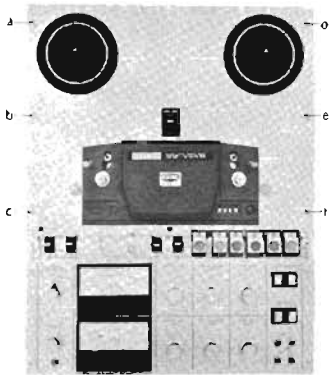

SCREWS

10

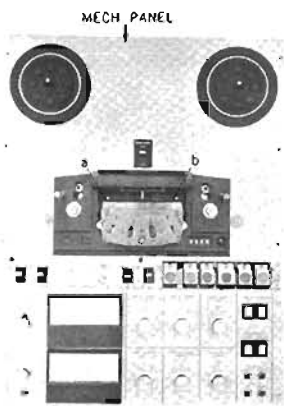

MECH / AMP ADJUSTMENT

11

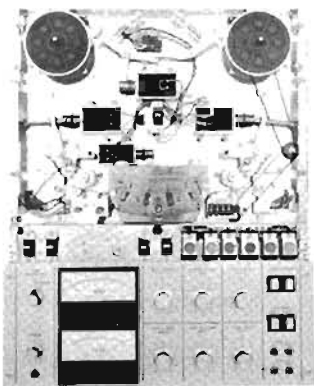

MECH / AMP ADJUSTMENT

12

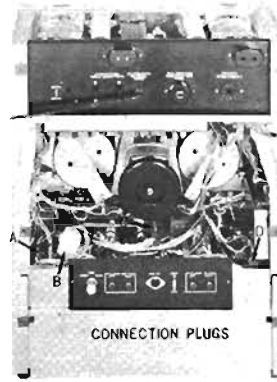

CONNECTION PLUGS

13

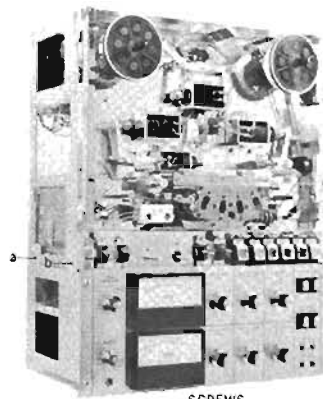

SCREWS

14

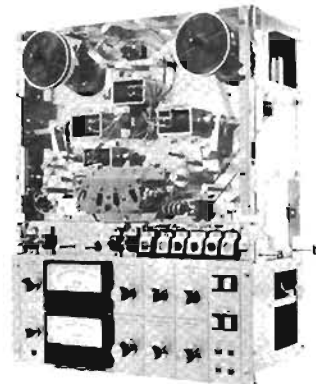

SCREWS

15



AMP BLOCK

IV. MECHANISM ADJUSTMENTS

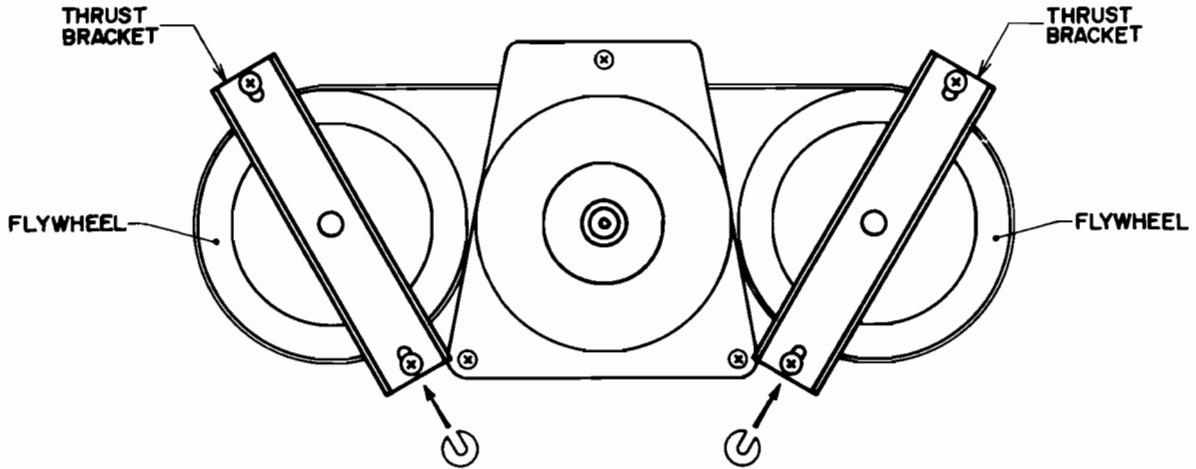

Fig. 8

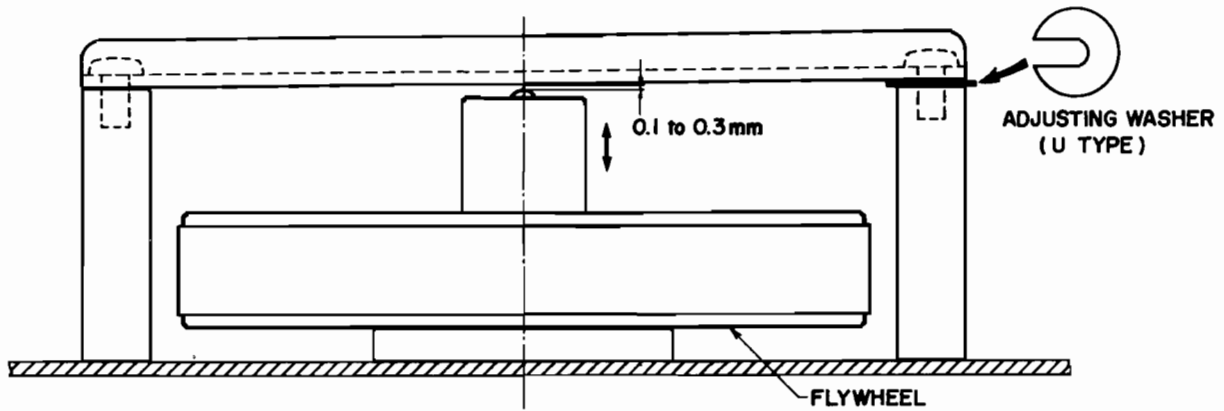

Fig. 9

1. FLYWHEEL LOOSE PLAY ADJUSTMENT

Adjust by inserting an Adjusting washer (U type) at the places indicated in Fig. 8 to obtain a 0.1 to 0.3 mm loose play when the flywheel is moved in the direction of the arrow shown in Fig. 9.

NOTE: When the flywheel is replaced, replace only with one of the same rank.

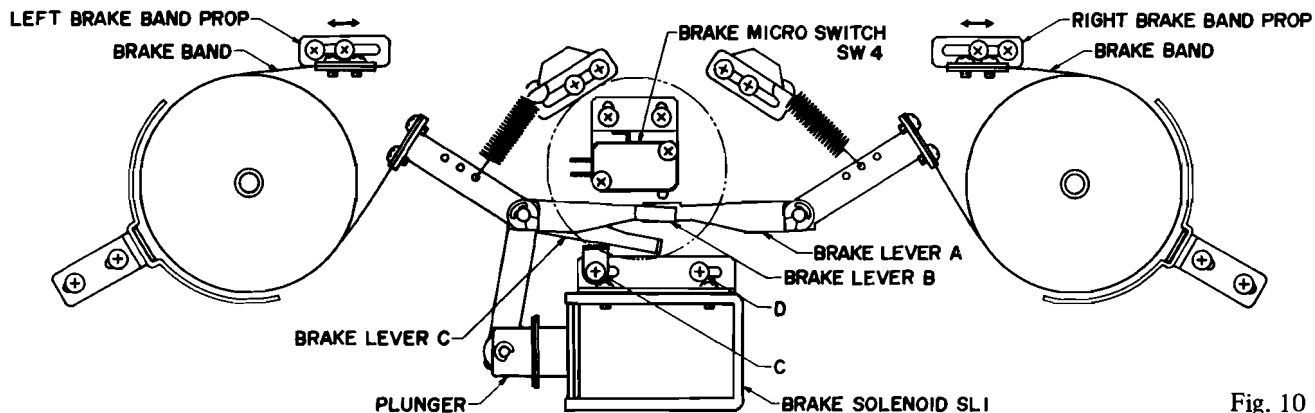

Fig. 10

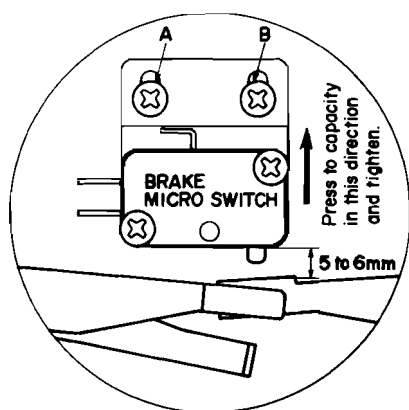

Fig. 11

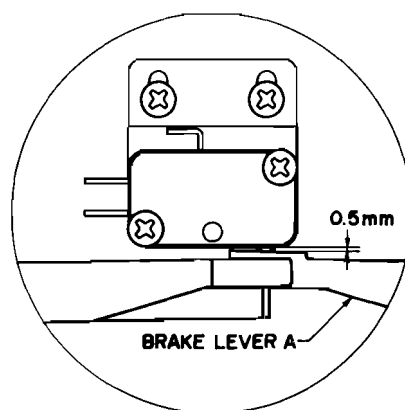

Fig. 12

2. BRAKE SOLENOID POSITION ADJUSTMENT

- 1) As shown in Fig. 11, press brake micro switch as far as it will go toward the top of the mechanical frame, and tighten screws A and B.
- 2) Move the Right Brake Band Prop shown in Fig. 10 so that the gap between Brake Lever A and the body of Brake Micro Switch is 5 to 6 mm (See Fig. 11).
- 3) Move the Left Brake Band Prop shown in Fig. 10 so that Brake Lever B and Brake Lever A are simultaneously operated by Brake Lever C.
- 4) As shown in Fig. 12, when the plunger is pulled, tighten Brake Solenoid Screws C and D at position at which the gap between Brake Lever A and the body of Brake Micro Switch is 0.5 mm at the narrowest place.

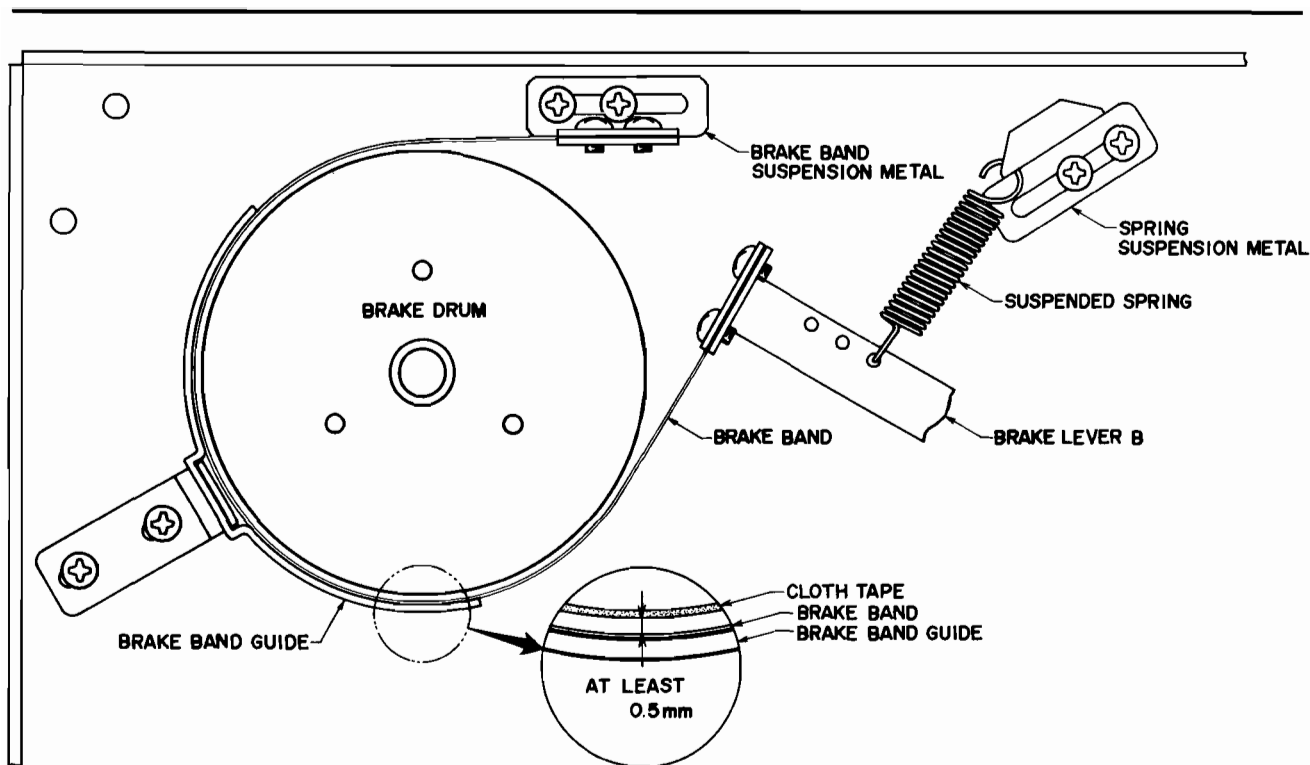

Fig. 13

3. BRAKE TENSION ADJUSTMENT

- 1) As shown in Fig. 14, brake tension is measured with a spring gauge using a 60 mm diameter tape wound on a 5" reel. Ideal brake tension is 650 ± 50 gr, and left/right deviation allowance should be within 50 gr.
- 2) Methods for brake tension adjustment are as follows: (See Fig. 13)
 - Method A: Change position of suspended spring.
 - Method B: Adjust position of spring suspension metal.

NOTE: Following Brake Tension Adjustment, confirm that when the machine is set to each of the various modes (except stop mode), the brake band separates from the cloth tape on the brake drum by at least 0.5 mm. (See Fig. 13)

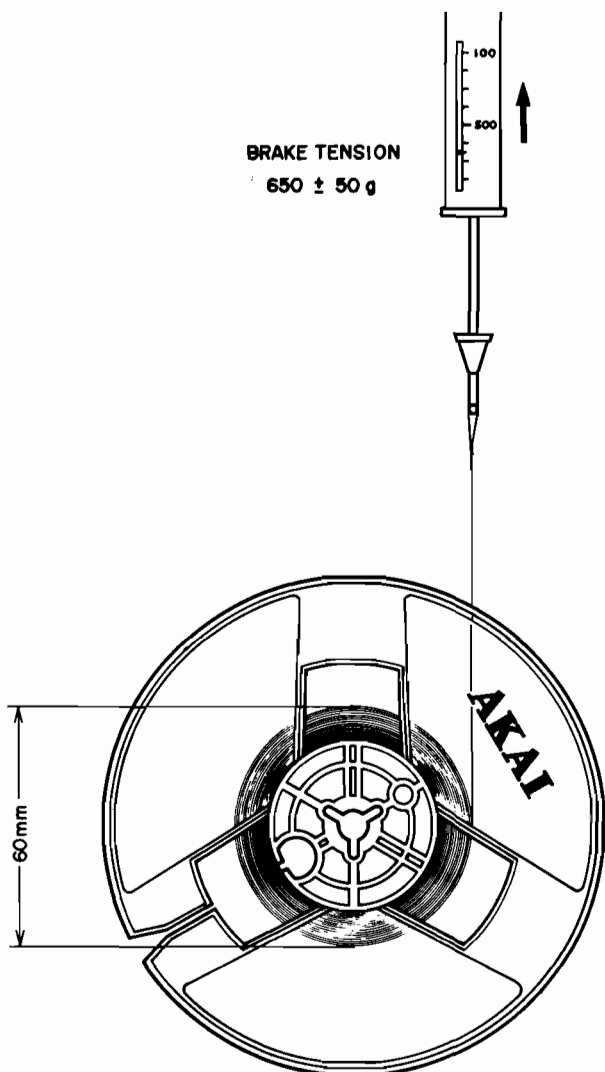

Fig. 14

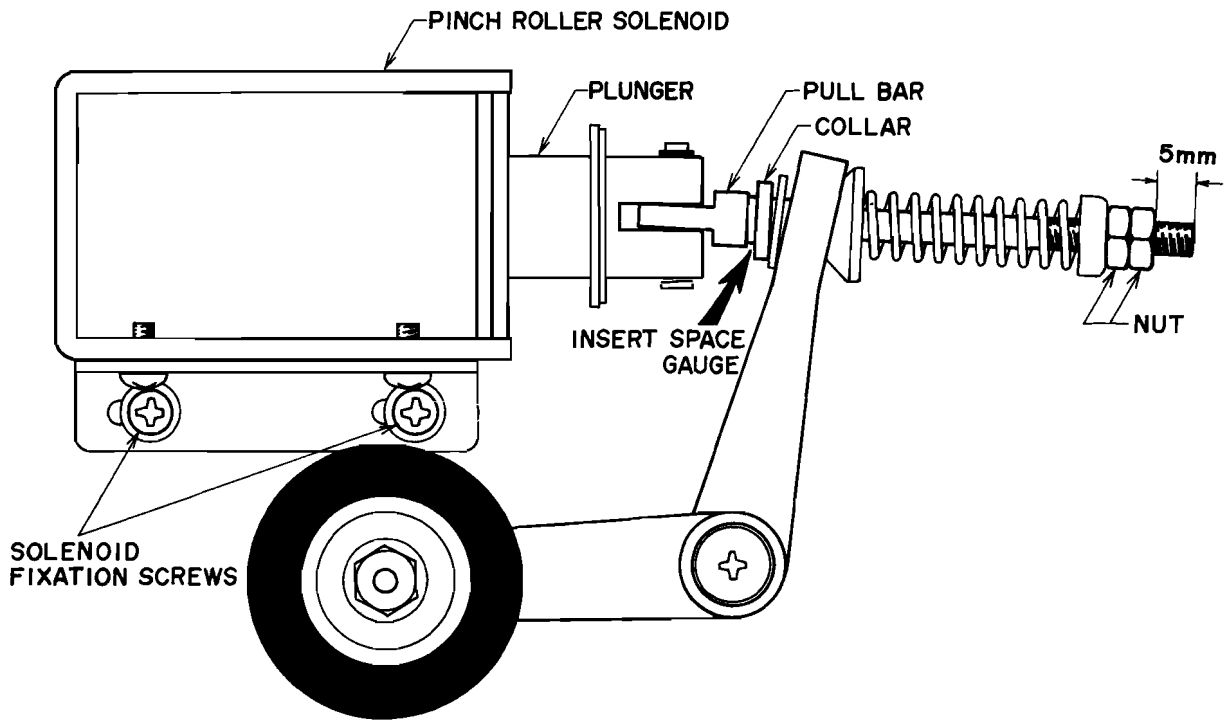

Fig. 15

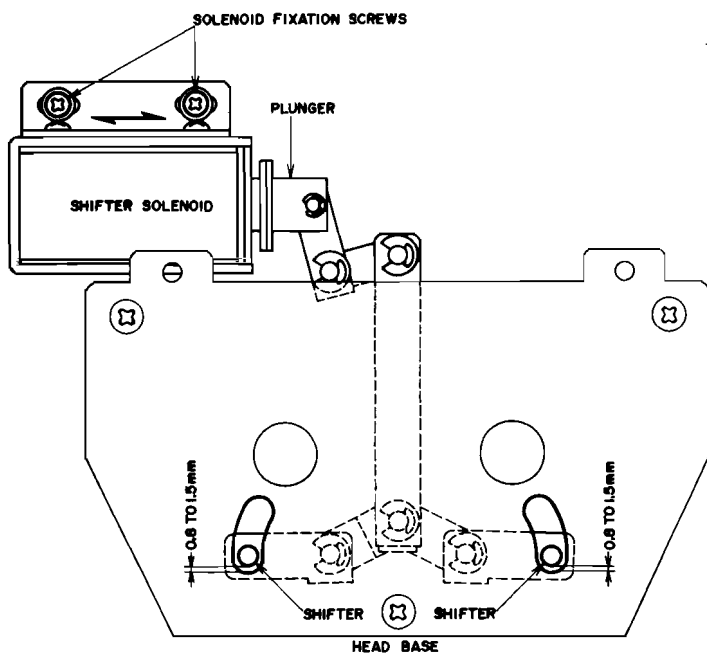

Fig. 17

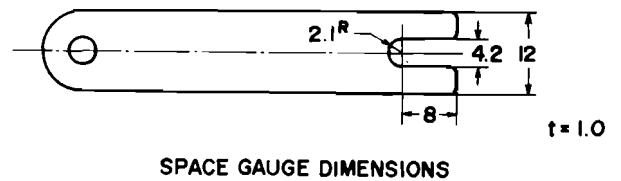

Fig. 16

4. PINCH ROLLER SOLENOID POSITION ADJUSTMENT

Set nut so that the screw part of the pull bar extends 5 mm further than the nut, and insert a space gauge of which the dimensions are the same as shown in Fig. 16 between the collar and pull bar shown in Fig. 15, and fix at position at which the pinch roller rests against the capstan. Set left and right to same degree.

5. SHIFTER SOLENOID POSITION ADJUSTMENT (See Fig. 17)

Adjust the position of the Shifter Solenoid so that when the plunger is pulled, the gap of the shifter and oblong hole of the head base is 0.8 to 1.5 mm.

NOTE: The tape must definitely not touch the head.

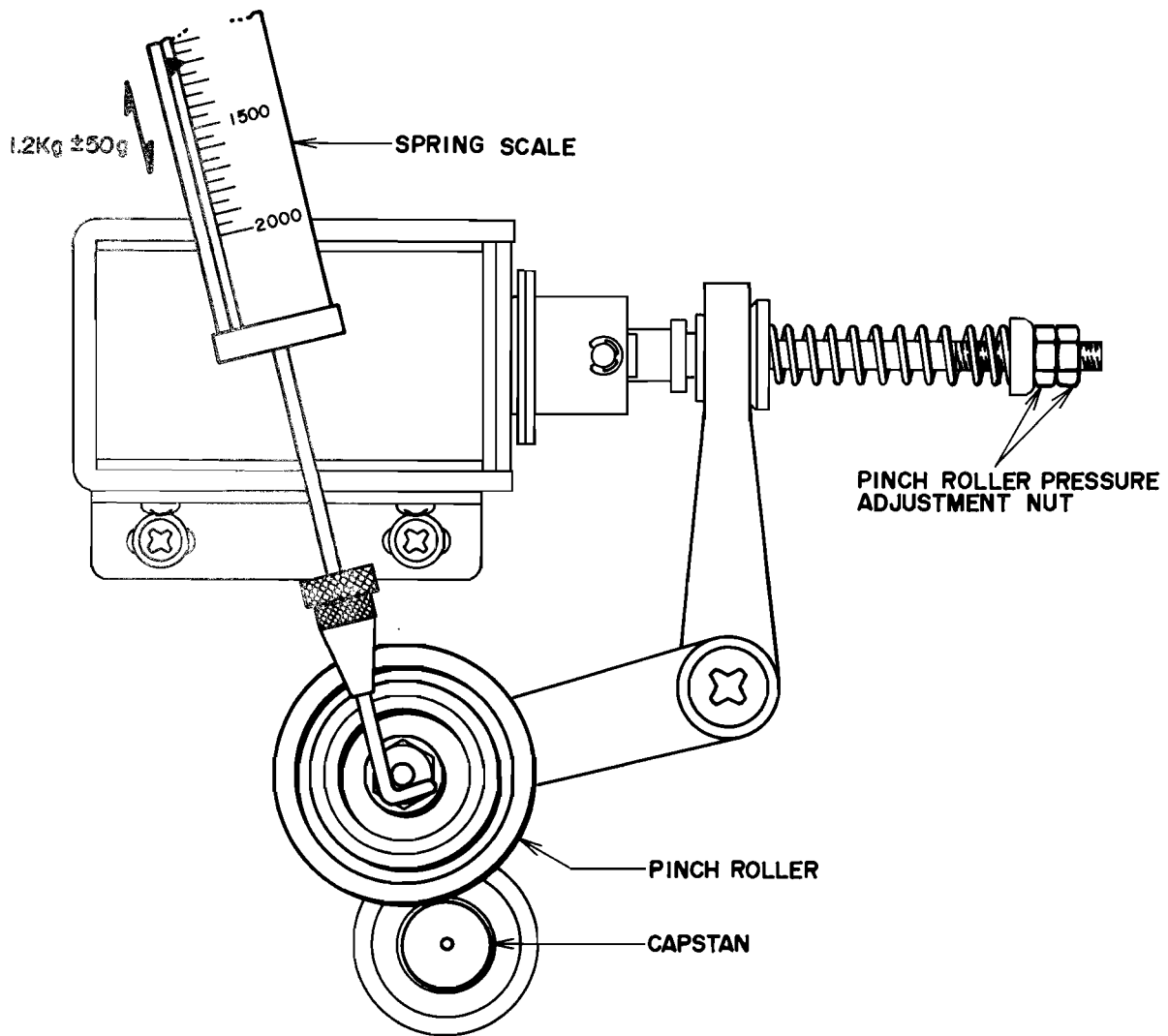

Fig. 18

6. PINCH ROLLER PRESSURE ADJUSTMENT (See Fig. 18)

As shown in Fig. 18, pull back the Pinch Roller with a spring scale, and then return. Take a reading of the spring scale indication at the time the pinch roller touches the capstan. Adjust Pinch Roller Pressure Adjustment nut to obtain a 1.2 kg±50 gr spring scale indication at this time.

NOTE: Because this model employs a dual capstan system, adjust so that the difference in pinch roller pressure between left and right is within 50 gr.

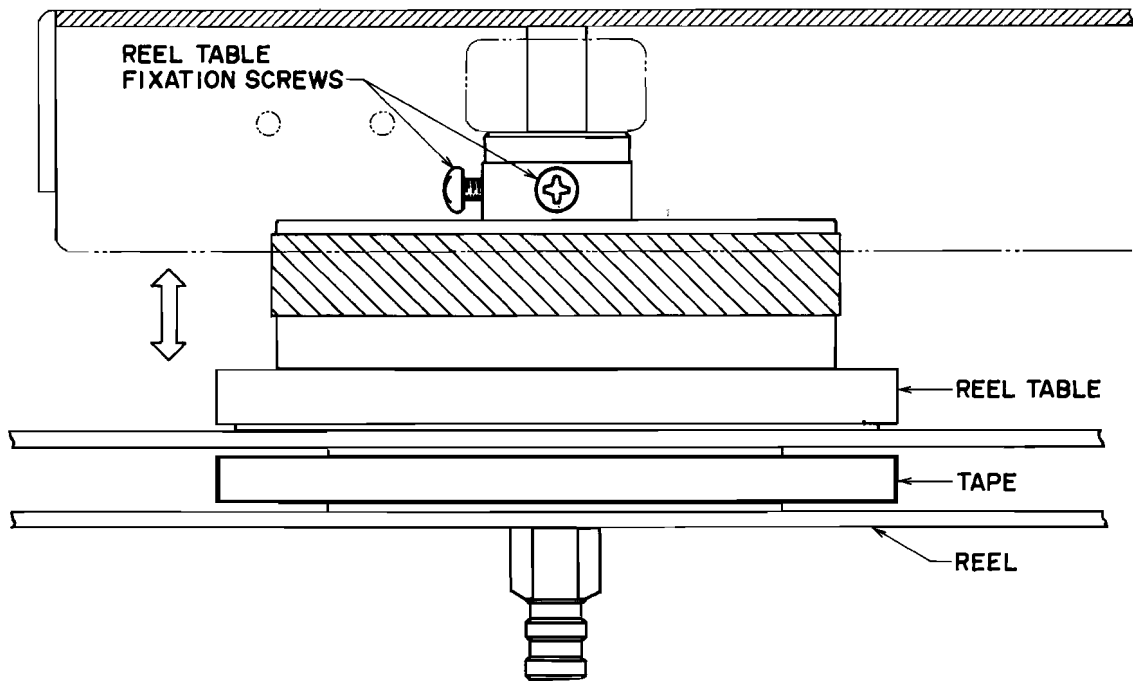

Fig. 19

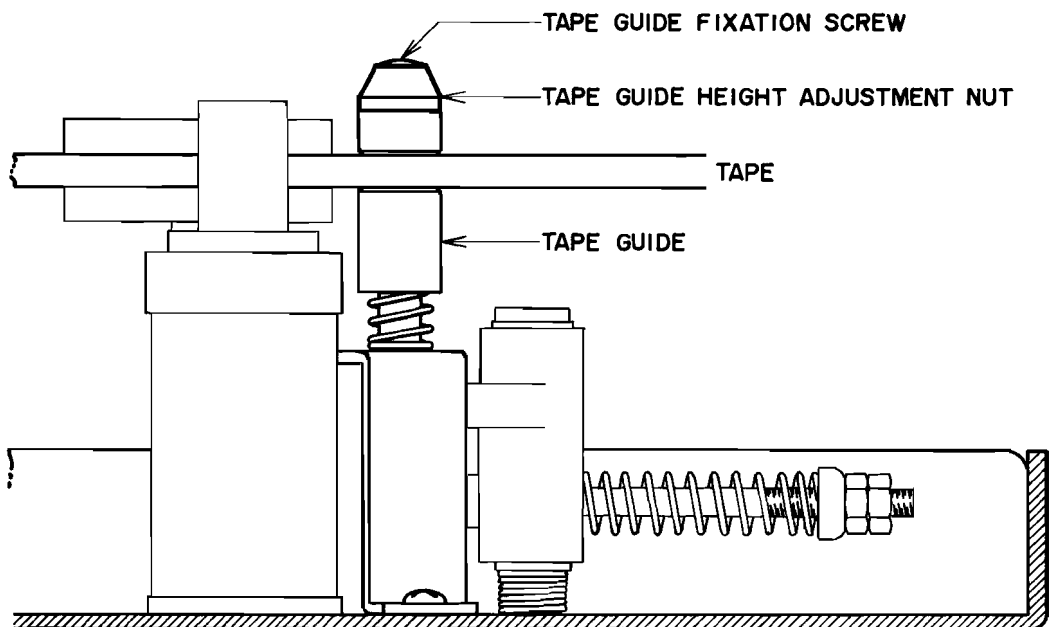

Fig. 20

7. REEL TABLE HEIGHT ADJUSTMENT
(See Fig. 19)

Load a tape (left and right reel tables), but do not thread tape through left/right tape guides and tension levers. Set to F.Fwd, and Rwd mode and adjust the position of reel tables in direction of arrow mark so that the tape winds in the center of the reels. Tighten reel table fixation screws at most ideal position.

8. TAPE GUIDE HEIGHT ADJUSTMENT
(See Fig. 20)

Thread tape over left and right tape guides, but do not thread over left and right tension levers. Loosen tape guide fixation screws and adjust left and right tape guide height adjustment nuts so that at Fwd and Rev modes, the tape runs on the center of the tape guides. Tighten tape guide fixation screws to maintain this condition.

NOTE: Tape should wind in center of reel regardless of type of reel used.

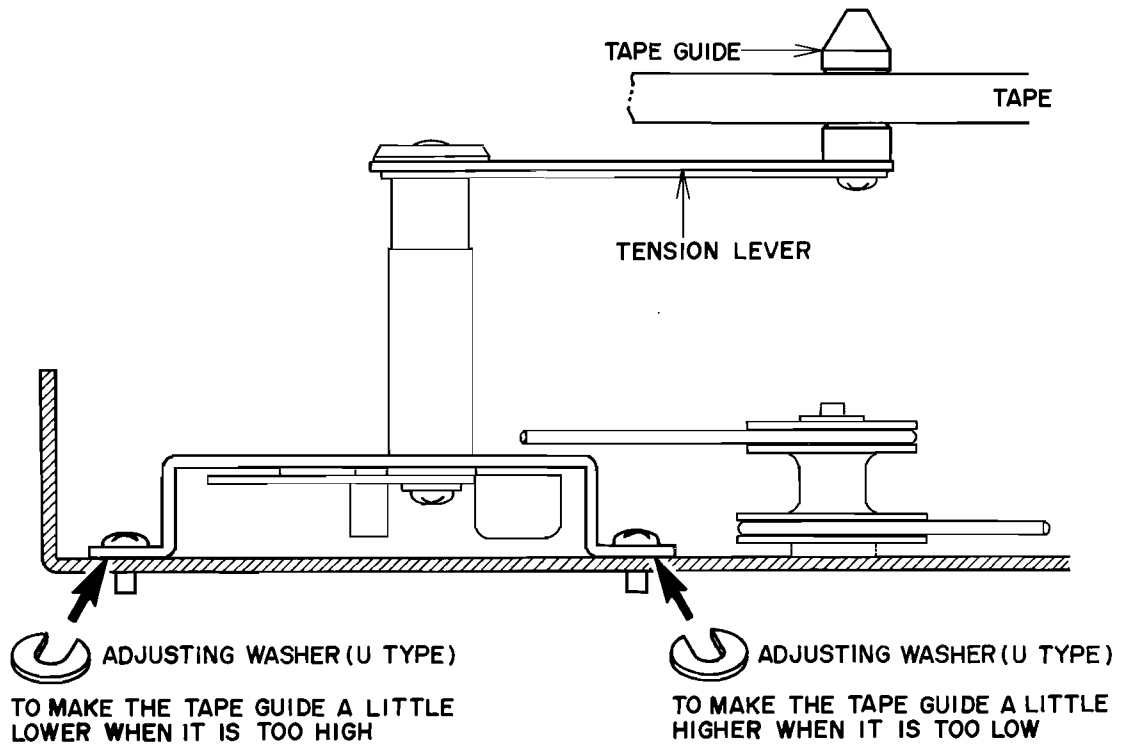

Fig. 21

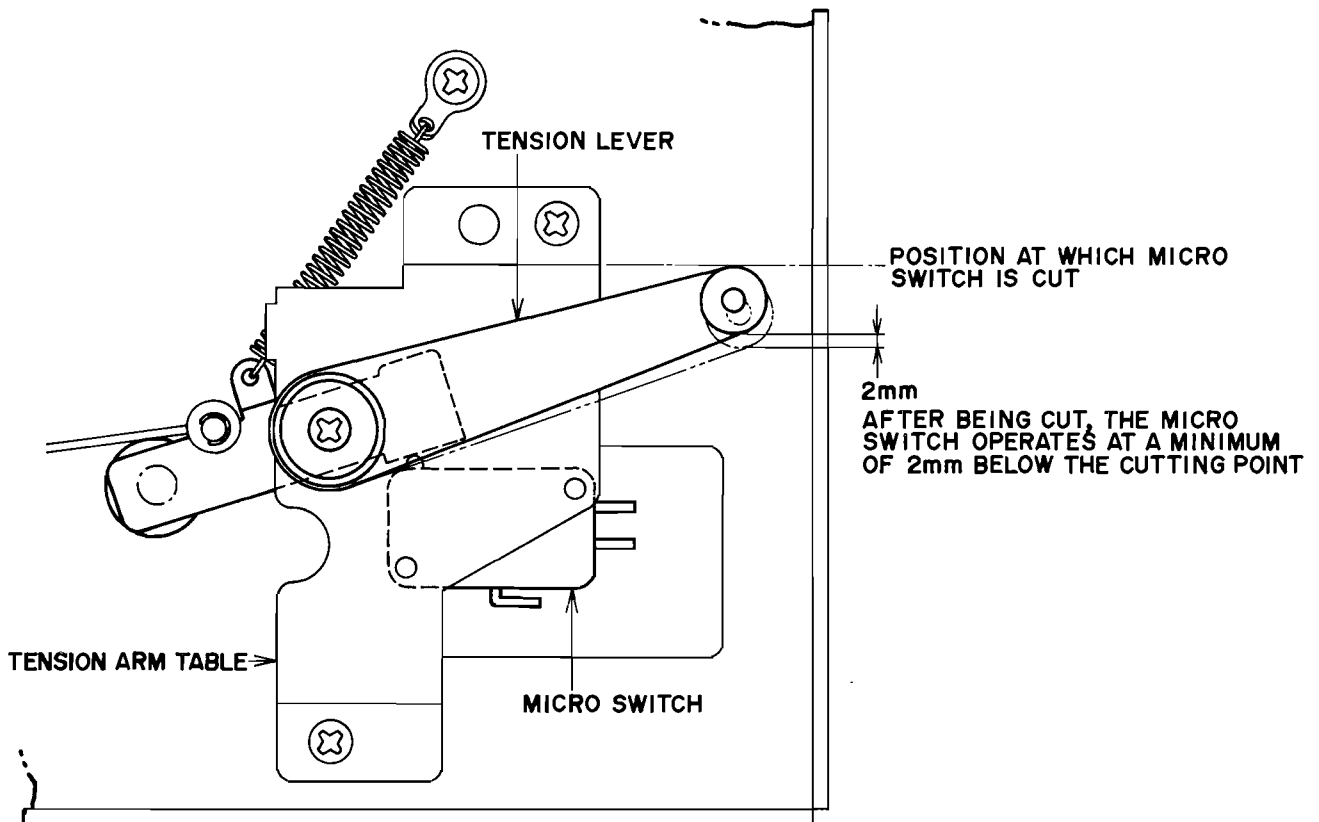

Fig. 22

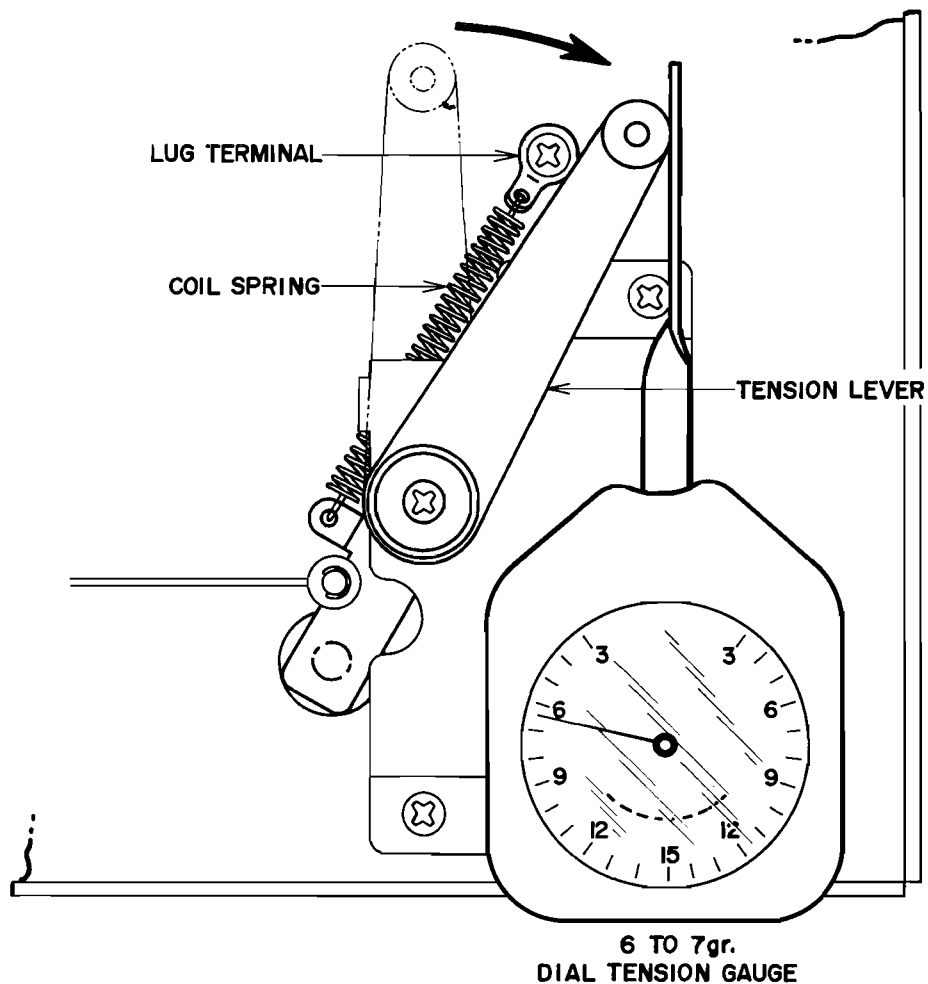

Fig. 23

9. TENSION LEVER HEIGHT ADJUSTMENT
(See Fig. 21)

Thread tape over left and right tension levers and over the left and right tape guides properly. Adjust tension lever height by inserting an Adjusting washer (U type) as shown in Fig. 21 so that at Fwd and Rev modes, the tape travels on the center of the tape guide.

NOTE: The right hand side tape guide is shown in Fig. 21, but when making the left hand side tension lever height adjustment, the screw on the left is used to make the tape guide higher, and the screw on the right is used to make the tape guide lower.

10. CONFIRMATION OF POINT AT WHICH LEFT AND RIGHT TENSION ARMS OPERATE

Confirm that the left and right micro switches operate at the positions indicated in Fig. 22.

11. TENSION ARM RETURN TENSION ADJUSTMENT

Bend the oval shaped lug terminal and adjust the strength of coil spring so that as shown in Fig. 23, when the tension arm returns in the direction of the arrow the tension registered with a tension gauge is 6 to 7 gr.

V. HEAD ADJUSTMENTS

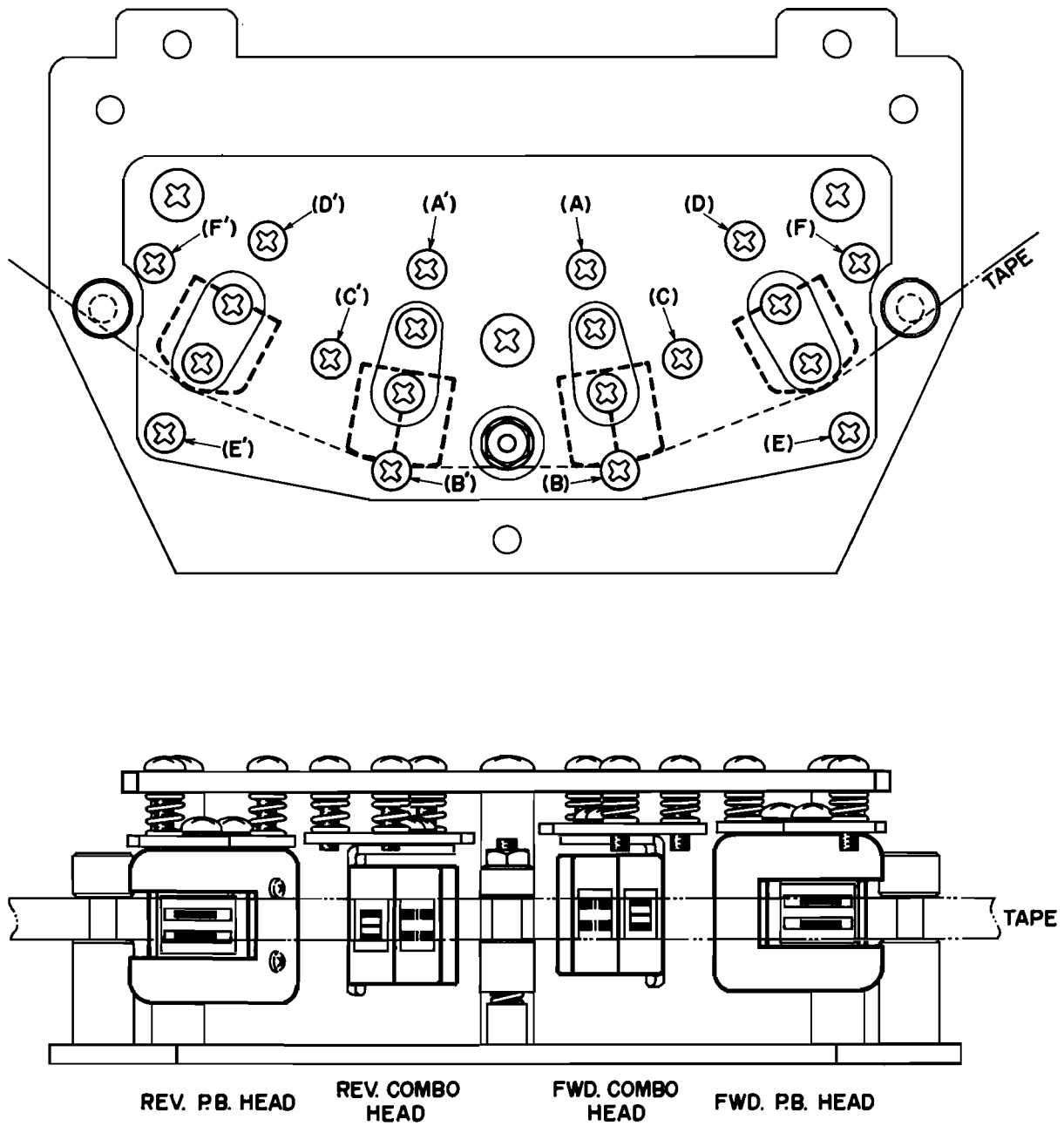
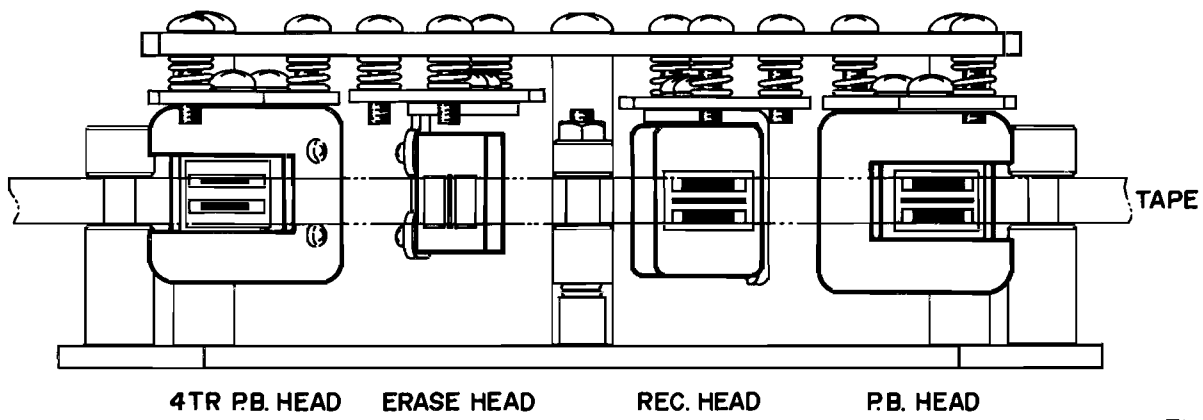
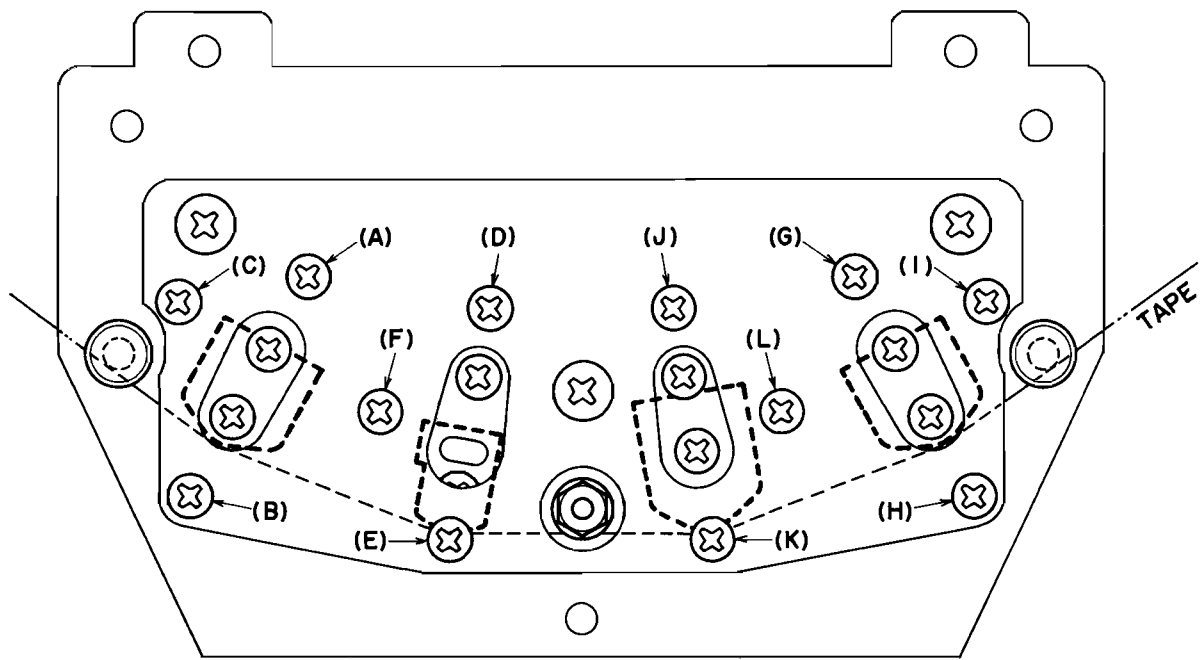

Fig. 24

1. MODEL: GX-400D

Adjustment Item	Test Tape, Supply Signal	Measuring Instrument Connection	Mode	Tape Speed	Adjustment Screw	Ref. Diagram	Remarks
FWD P.B. Head Height Adjustment	Optional		FWD	Optional	(D)(E)(F)	Fig. 24	Even Upper Edge of Ch. 1 Head Core and Upper Edge of Tape
FWD Combo Head Height Adjustment	Optional		FWD	Optional	(A)(B)(C)	Fig. 24	Even Upper Edge of Ch. 1 Rec. Head Core and Upper Edge of Tape
REV P.B. Head Height Adjustment	Optional		REV	Optional	(D')(E')(F')	Fig. 24	Even Lower Edge of Ch. 1 P.B. Head Core and Lower Edge of Tape
REV Combo Head Height Adjustment	Optional		REV	Optional	(A')(B')(C')	Fig. 24	Even Lower Edge of Ch. 1 Rec. Head Core and Lower Edge of Tape
FWD P.B. Head Azimuth Alignment Adjustment	15,000 Hz (15 ips) Test Tape	High Sensitivity V.T.V.M. to Line Output	FWD	15 ips	(F)	Fig. 24	Maximum Line Output, Both Channels
REV P.B. Head Azimuth Alignment Adjustment	15,000 Hz (15 ips) Test Tape	High Sensitivity V.T.V.M. to Line Output	REV	15 ips	(F')	Fig. 24	Maximum Line Output, Both Channels
FWD Combo Head Azimuth Alignment Adjustment	15,000 Hz -20 dB Signal to Line Input	High Sensitivity V.T.V.M. to Line Output	FWD REC	15 ips	(C)	Fig. 24	Maximum Line Output, Both Channels
REV Combo Head Azimuth Alignment Adjustment	15,000 Hz -20 dB Signal to Line Input	High Sensitivity V.T.V.M. to Line Output	REV REC	15 ips	(C')	Fig. 24	Maximum Line Output, Both Channels

Chart 1



4TR P.B. HEAD ERASE HEAD REC. HEAD P.B. HEAD

Fig. 25

2. MODEL: GX-400D PRO

Adjustment Item	Test Tape, Supply Signal	Measuring Instrument Connection	Mode	Tape Speed	Adjustment Screw	Ref. Diagram	Remarks
4TR P.B. Head Height Adjustment	Optional		FWD	Optional	(A)(B)(C)	Fig. 25	Even Upper Edge of Ch. 1 Head Core and Upper Edge of Tape
Erase Head Height Adjustment	Optional		FWD	Optional	(D)(E)(F)	Fig. 25	Protruding Top & Bottom Edges of Head Core Equidistant (Tape runs on exact center of Head Core)
REC. Head Height Adjustment	Optional		FWD	Optional	(J)(K)(L)	Fig. 25	Even Upper Edge of Ch. 1 Head Core and Upper Edge of Tape
P.B. Head Height Adjustment	Optional		FWD	Optional	(G)(H)(I)	Fig. 25	Even Upper Edge of Ch. 1 Head Core and Upper Edge of Tape
4TR P.B. Head Azimuth Alignment Adjustment	15,000 Hz (15 ips) Test Tape	High Sensitivity V.T.V.M. to Line Output	FWD/4TR	15 ips	(C)	Fig. 25	Maximum Line Output, Both Channels
2TR P.B. Head Azimuth Alignment Adjustment	15,000 Hz (15 ips) Test Tape	High Sensitivity V.T.V.M. to Line Output	FWD/4TR	15 ips	(T)	Fig. 25	Maximum Line Output, Both Channels
REC. Head Azimuth Alignment Adjustment	15,000 Hz -20 dB Signal to Line Input	High Sensitivity V.T.V.M. to Line Output	FWD REC/2TR	15 ips	(L)	Fig. 25	Maximum Line Output, Both Channels

Chart 2

VI. AMP. SYSTEM ADJUSTMENTS

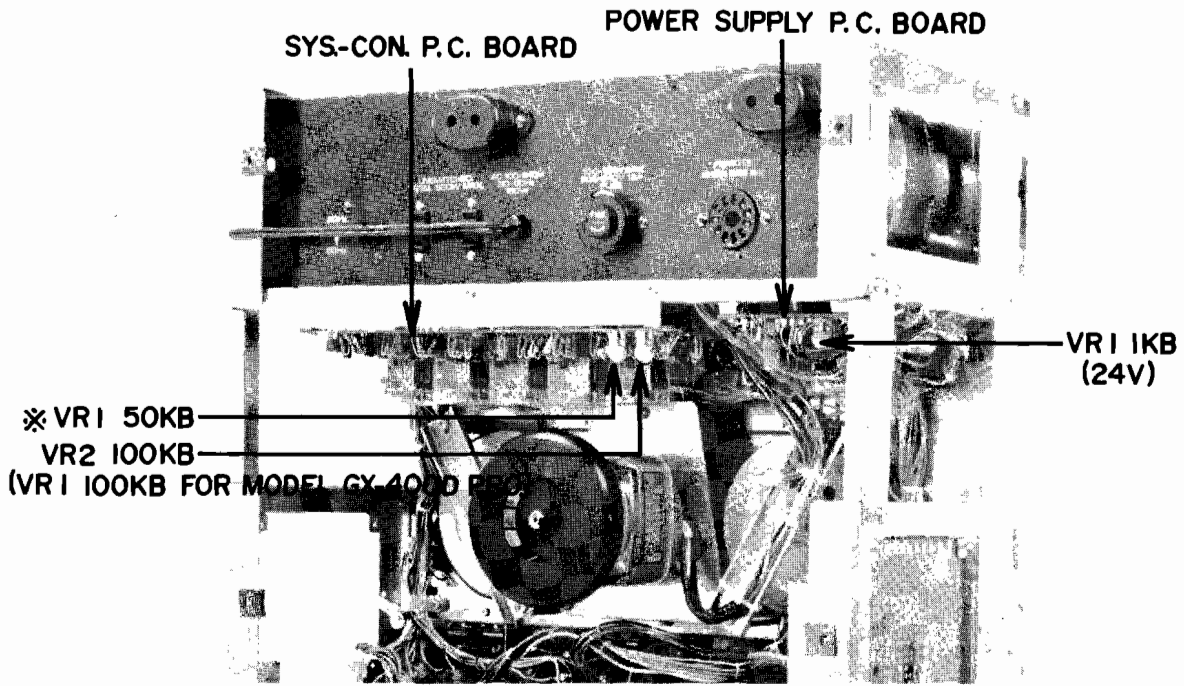

NOTE: THE SEMI-FIXED RESISTOR MARKED WITH * IS NOT USED IN MODEL GX-400D PRO.

Fig. 26

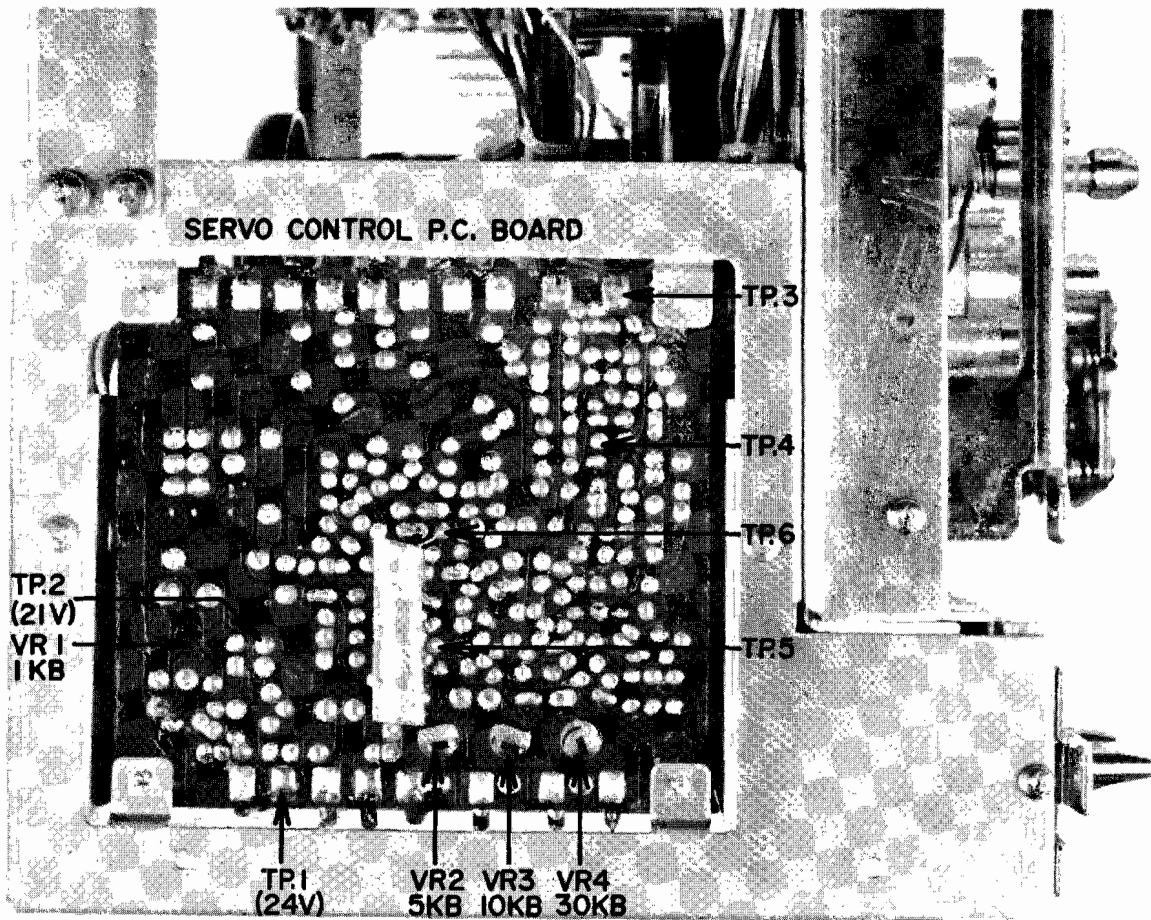

Fig. 27

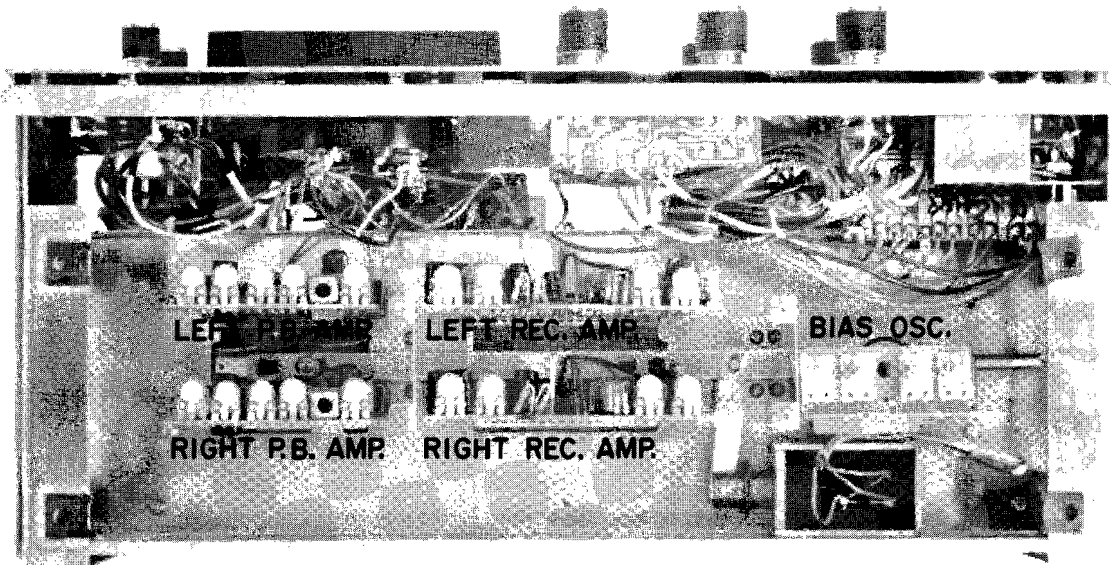
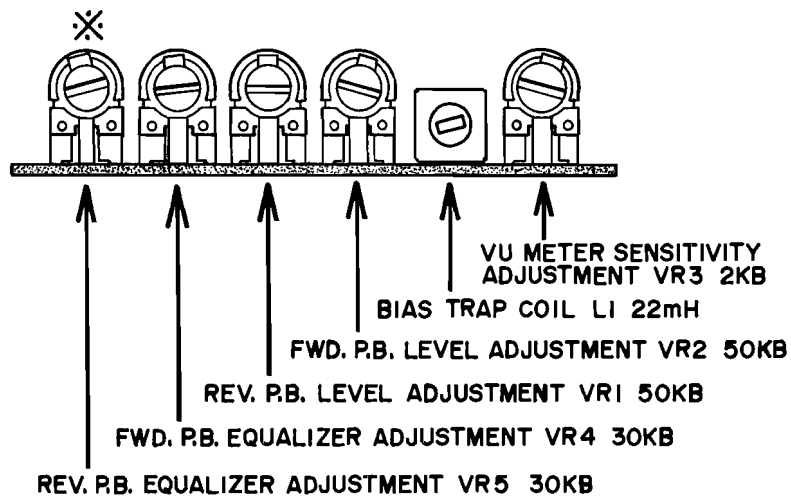
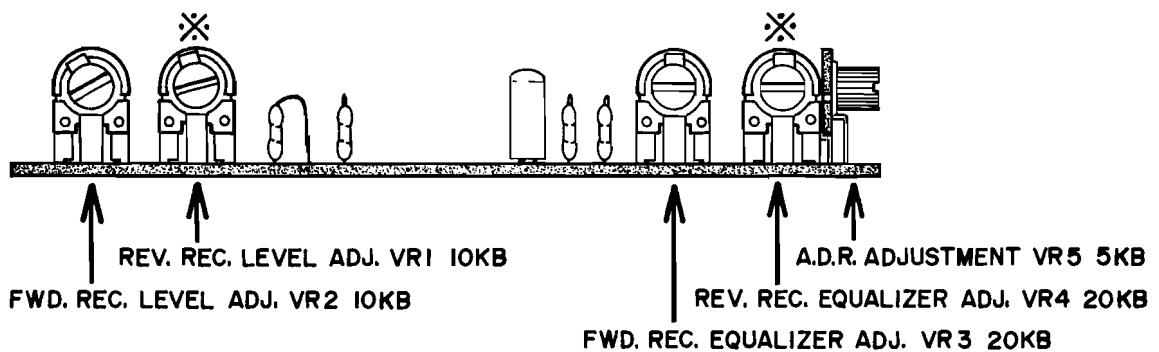

Fig. 28 Arrangement of Each Amp. System P.C. Board



NOTE: THE SEMI-FIXED RESISTOR MARKED WITH * ARE NOT USED IN MODEL GX-400D PRO.

Fig. 29 PLAYBACK AMP. P.C. BOARD



NOTE: THE SEMI-FIXED RESISTORS MARKED WITH * ARE NOT USED IN MODEL GX-400D PRO.

Fig. 30 RECORDING AMP. P.C. BOARD

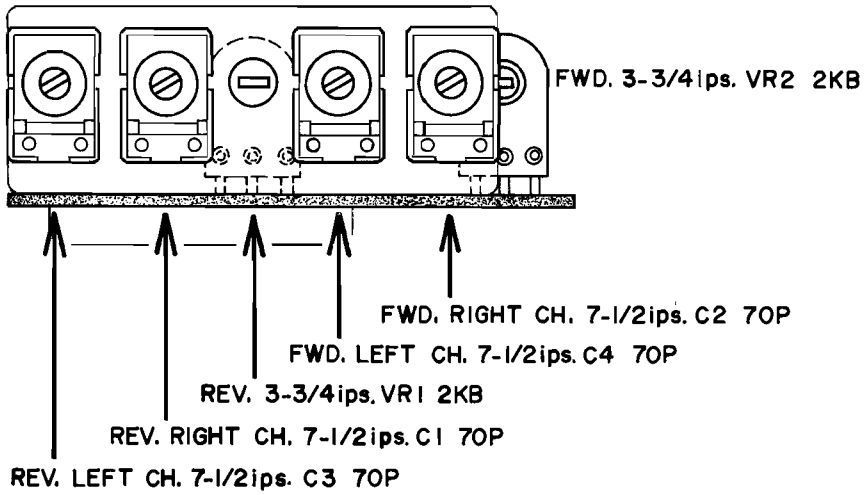

Fig. 31 OSC. P.C. BOARD (GX-400D)

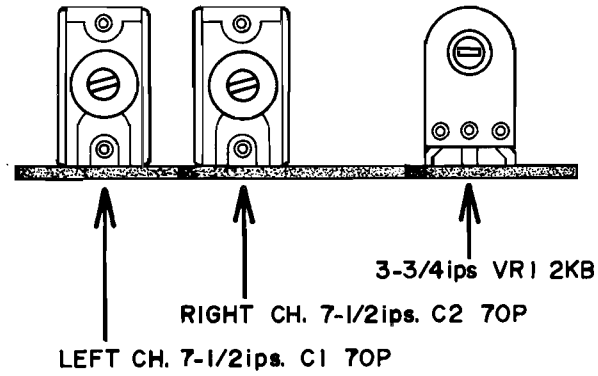

Fig. 32 OSC. P.C. BOARD (GX-400D PRO)

1. MODEL: GX-400D

Adjustment Item	Test Tape, Supply Signal	Measuring Instrument Connection	Mode	Tape Speed	Adjustment	Result	Ref. Diagram	Remarks
Power Source Circuit Voltage Adjustment	/	V.T.V.M. or Tester between Test Point TP-1 and Ground	STOP	/	VR1 1kB	24.0V	Fig. 26	TP-1 (See Fig. 27)
Servo Control Circuit Voltage Adjustment	/	V.T.V.M. or Tester between Test Point TP-2 and Ground	STOP	/	VR1 1kB	21.0V	Fig. 27	Must first be adjusted to 24V
15 ips (38cm/sec.) Tape Speed Adjustment	1,000 Hz 7-1/2 ips Test Tape	Frequency Counter to Line Output	FWD	15 ips	VR2 5kB	2,000Hz ±1.5%	Fig. 27	
7-1/2 ips (19cm/sec.) Tape Speed Adjustment	1,000 Hz 7-1/2 ips Test Tape	Frequency Counter to Line Output	FWD	7-1/2 ips	VR3 10kB	1,000 Hz ±1.5%	Fig. 27	
3-3/4 ips (9.5cm/sec.) Tape Speed Adjustment	1,000 Hz 7-1/2 ips Test Tape	Frequency Counter to Line Output	FWD	3-3/4 ips	VR3 30kB	500Hz ±1.5%	Fig. 27	
FWD Playback Level Adjustment	700Hz 15 ips Test Tape	High Sensitivity V.T.V.M. to Line Output	FWD	15 ips	VR2 50kB	0(0.775V) ±1dB	Fig. 29	
REV Playback Level Adjustment	700Hz 15 ips Test Tape	High Sensitivity V.T.V.M. to Line Output	REV	15 ips	VR1 50kB	0(0.775V) ±1dB	Fig. 29	
VU Meter Sensitivity Adjustment	700Hz 15 ips Test Tape	High Sensitivity V.T.V.M. to Line Output	FWD	15 ips	VR3 2kB	OVU	Fig. 29	
FWD Playback Equalizer Adjustment	15,000Hz 15 ips Test Tape	High Sensitivity V.T.V.M. to Line Output	FWD	15 ips	VR4 30kB	+1dB	Fig. 29	
REV Playback Equalizer Adjustment	15,000Hz 15 ips Test Tape	High Sensitivity V.T.V.M. to Line Output	REV	15 ips	VR5 30kB	+1dB	Fig. 29	
FWD 7-1/2 ips (19cm/sec.) Recording Bias Adjustment	1,000Hz -46dB(4mV) to Mic Input	Audio Frequency Oscillator to Line Input, High Sensitivity V.T.V.M. to Line Output	FWD REC	7-1/2 ips	C4 70P(left) C2 70P(right)	Maximum	Fig. 31	1,000Hz-20dB Recording
REV 7-1/2 ips (19cm/sec.) Recording Bias Adjustment	1,000Hz -46dB(4mV) to Mic Input	Audio Frequency Oscillator to Line Input, High Sensitivity V.T.V.M. to Line Output	REV REC	7-1/2 ips	C3 70P(left) C1 70P(right)	Maximum	Fig. 31	1,000Hz-20dB Recording
FWD 7-1/2 ips (19cm/sec.) Recording Equalizer Adjustment	1,000Hz, 15,000Hz -46dB(4mV) to Mic Input	Audio Frequency Oscillator to Line Input, High Sensitivity V.T.V.M. to Line Output	FWD REC	7-1/2 ips	VR3 20kB	0dB/ 1,000Hz +1dB/ 15,000Hz	Fig. 30	1,000Hz-20dB Recording If A.D.R. Adjustment is necessary, refer to Section VII.

REV 7-1/2 ips (19cm/sec.) Recording Equalizer Adjustment	1,000Hz. 15,000Hz -46dB(4mV) to Mic Input	Audio Frequency Oscillator to Line Input, High Sensitivity V.T.V.M. to Line Output	REV REC	7-1/2 ips	VR4 20kB	0dB/ 1,000Hz +1dB/ 15,000Hz	Fig. 30	1,000Hz -20dB Recording If A.D.R. Adjust- ment is necessary, refer to Section VII.
FWD 3-3/4 ips (19cm/sec.) Recording Equalizer Adjustment	1,000Hz, 10,000Hz -46dB(4mV) to Mic Input	Audio Frequency Oscillator to Line Input, High Sensitivity V.T.V.M. to Line Output	FWD REC	3-3/4 ips	VR2 2kB	0dB/ 1,000Hz 1±0.5dB/ 10,000Hz	Fig. 31	1,000Hz -20dB Recording
REV 3-3/4 ips (9.5cm/sec.) Recording Bias Adjustment	1,000Hz, 10,000Hz -46dB(4mV) to Mic Input	Audio Frequency Oscillator to Line Input, High Sensitivity V.T.V.M. to Line Output	REV REC	3-3/4 ips	VR1 2kB	0dB/ 1,000Hz 1±0.5dB/ 10,000Hz	Fig. 31	1,000Hz -20dB Recording
FWD REC Level Adjustment	1,000Hz -46dB(4mV) to Mic Input	Audio Frequency Oscillator to Line Input, High Sensitivity V.T.V.M. to Line Output	REV REC	15 ips	VR2 10kB	0±1.5dB	Fig. 30	1,000Hz 0dB Recording
REV REC Level Adjustment	1,000Hz -46dB(4mV) to Mic Input	Audio Frequency Oscillator to Line Input, High Sensitivity V.T.V.M. to Line Output	REV REC	15 ips	VR1 10kB	0±1.5dB	Fig. 30	1,000Hz 0dB Recording
Bias Leak Adjustment	/	High Sensitivity V.T.V.M. to Line Output	FWD REC	7-1/2 ips	L1 22mH	Less than -30dB (Stereo) Less than -20dB (Monaural)	Fig. 29	
Direct Function Time Constant Adjustment	1,000Hz -46dB(4mV) to Mic Input	/	FWD → REV REV → FWD	15 ips	VR1 50kB	Within 4 sec.	Fig. 29	
	1,000Hz -46dB(4mV) to Mic Input	/	F.FWD or RWD → FWD or REV	15 ips	VR2 100kB	Within 4 sec.	Fig. 26	

Chart 3

2. MODEL: GX-400D PRO

Adjustment Item	Test Tape, Supply Signal	Measuring Instrument Connection	Mode	Tape Speed	Adjustment	Result	Ref. Diagram	Remarks
Power Source Circuit Voltage Adjustment	/	V.T.V.M. or Tester between Test Point TP-1 and Ground	STOP	/	VR1 1kB	24.0V	Fig. 26	TP-1 (See Fig. 27)

Servo Control Circuit Voltage Adjustment		V.T.V.M. or Tester between Test Point TP-2 and Ground	STOP		VR1 1kB	21.0V	Fig. 27	Must first be adjusted to 24V
15 ips (38cm/sec.) Tape Speed Adjustment	1,000Hz 7-1/2 ips Test Tape	Frequency Counter to Line Output	FWD	15 ips	VR2 5 kB	2,000Hz $\pm 1.5\%$	Fig. 27	
7-1/2 ips (19cm/sec.) Tape Speed Adjustment	1,000Hz 7-1/2 ips Test Tape	Frequency Counter to Line Output	FWD	7-1/2 ips	VR3 10kB	1,000Hz $\pm 1.5\%$	Fig. 27	
3-3/4 ips (9.5cm/sec.) Tape Speed Adjustment	1,000Hz 7-1/2 ips Test Tape	Frequency Counter to Line Output	FWD	3-3/4 ips	VR4 30kB	500Hz $\pm 1.5\%$	Fig. 27	
2TR Playback Level Adjustment	700Hz 15 ips Test Tape	High Sensitivity V.T.V.M. to Line Output	FWD	15 ips	VR1 50kB	0(0.775V) $\pm 1dB$	Fig. 29	
4TR Playback Level Adjustment	700Hz 15 ips Test Tape	High Sensitivity V.T.V.M. to Line Output	FWD	15 ips	VR2 50kB	0(0.775V) $\pm 1dB$	Fig. 29	
VU Meter Sensitivity Adjustment	700Hz 15 ips Test Tape	High Sensitivity V.T.V.M. to Line Output	FWD	15 ips	VR3 2kB	OVU	Fig. 29	
Playback Equalizer Adjustment	15,000Hz 15 ips Test Tape	High Sensitivity V.T.V.M. to Line Output	FWD	15 ips	VR4 30kB	+1dB	Fig. 29	
Recording Bias Adjustment 7-1/2 ips (19cm/sec.)	1,000Hz -46dB (4mV) to Mic Input	Audio Frequency Oscillator to Mic Input, High Sensitivity V.T.V.M. to Line Output	REC	7-1/2 ips	C1 70P(left) C2 70P(right)	Maximum	Fig. 32	1,000Hz-20dB Recording
Recording Equalizer Adjustment 7-1/2 ips (19cm/sec.)	1,000Hz, 10,000Hz, -46dB(4mV) to Mic Input	Audio Frequency Oscillator to Mic Input, High Sensitivity V.T.V.M. to Line Output	REC	7-1/2 ips	VR3 20kB	0dB/ 1,000Hz +1dB/ 15,000Hz	Fig. 30	1,000Hz-20dB Recording If ADR Adjustment is necessary, refer to Section VII.
Recording Bias Adjustment 3-3/4 ips (9.5cm/sec.)	1,000Hz, 10,000Hz -46dB(4mV) to Mic Input	Audio Frequency Oscillator to Mic Input, High Sensitivity V.T.V.M. to Line Output	REC	3-3/4 ips	VR1 2kB	0dB/ 1,000Hz $1 \pm 0.5dB$ / 10,000Hz	Fig. 32	1,000Hz -20dB Recording
Recording Level Adjustment	1,000Hz -46dB(4mV) to Mic Input	Audio Frequency Oscillator to Mic Input, High Sensitivity V.T.V.M. to Line Output	REC	15 ips	VR2 10kB	0 $\pm 1.5dB$	Fig. 30	1,000Hz 0dB Recording
Bias Leak Adjustment		High Sensitivity V.T.V.M. to Line Output	REC		L1 22mH	Less than -30VU	Fig. 29	
Direct Function Time Constant Adjustment			F.Fwd or Rwd to Fwd	15 ips	VR1 100kB	Within 4 sec.	Fig. 26	

Chart 4

VII. RECORDING EQUALIZER AND A.D.R. ADJUSTMENTS

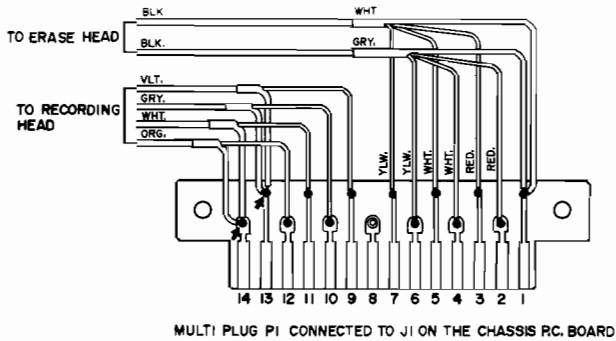

Fig. 33

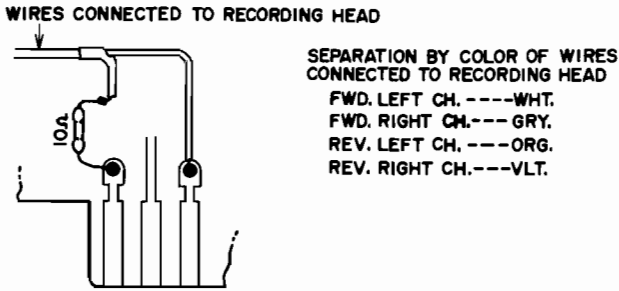

Fig. 34

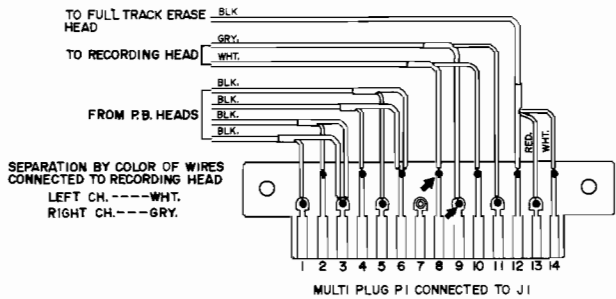

Fig. 35

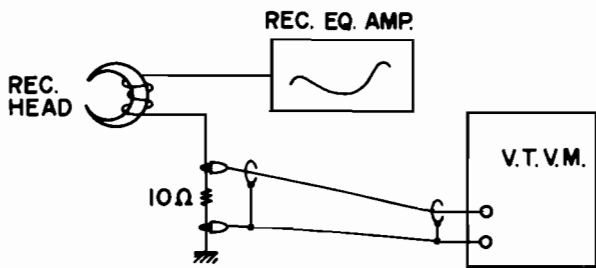

Fig. 36

- As shown in Figs. 33 and 35, disconnect the ground side wires connected to multi plug recording head, and connect a 10Ω fixed resistor in series between the ground wires as shown in Fig. 34.
- As shown in Fig. 36, connect a High Sensitivity V.T.V.M. to both terminals of the 10Ω fixed resistor.
- Temporarily remove the emitter resistor of Oscillator P.C. Board Transistors TR2, 3 (GX-400D) or TR1, 2 (GX-400D PRO), and set deck to recording mode (Bias Voltage is not supplied to Recording Head).
- Turn ADR Adjustment semi-fixed resistor of Rec. Amp. P.C. Board fully clockwise as shown in Fig. 30. Set Rec. Equalizer Adjustment semi-fixed resistor to 12 o'clock position, and depress SOURCE Button. (ADR does not function)
- Set tape speed to 3-3/4 ips, and Tape Selector to NORMAL.
- Supply a 1,000 Hz signal to the Line Input from an audio frequency oscillator, and adjust Recording Level Adjustment volume to obtain a -50 dB V.T.V.M. indication: (This voltage furnishes the 1,000 Hz OVU recording signal current.)
- Switch to 10,000 Hz frequency, and with Equalizer Adjustment volume, set the 10,000 Hz voltage to -41 dB. (Set 10,000 Hz to +9 dB in relation to 1,000 Hz)
- In case of Model GX-400D, set machine to FWD and REV modes in Steps 6 and 7.
- Next, set frequency to 15,000 Hz (GX-400D) or 20,000 Hz (GX-400D PRO), turn ADR Adjustment volume counter-clockwise until the 15,000 Hz voltage is -43dB (or the 20,000 Hz voltage is -45 dB).

NOTE: When making adjustment in Item 9, in case of model GX-400D, the machine can be set to either FWD or REV mode.

- It is advisable to paint lock Equalizer and ADR Adjustment semi-fixed resistors following adjustment.

Frequency Level Setting According to Model Number

Frequency	1,000 Hz	10,000 Hz	15,000 Hz	20,000 Hz
Model				
GX-400D	-50 dB	-41 dB		-45 dB
GX-400D PRO	-50 dB	-41 dB	-43 dB	

Chart 5

VIII. EXPLANATION

OF A.C SERVO CONTROL OPERATION

1. CIRCUIT OPERATION (Refer to Schematic Diagram)

- 1) The A.C. signal which is generated at the detector coil by capstan motor revolutions passes the high pass filter (H.P.F.) and is supplied to the base of TR3.

*It is necessary for the signal generated at the detection coil to pass the H.P.F. because of a hum element included in the signal caused by the 50/60 Hz power source frequency and pulsive noise.

- 2) At 15 ips motor revolutions, because the A.C. signal generated at the detector coil is a limited level signal of about 800 mVp-p, 1,500 Hz frequency, it is amplified at TR3, 4 until the waveform of the signal is clipped.
- 3) One of the TR4 output signal enters the differential circuit unchanged and the minus signal is cut at D2. The other output signal is amplified and phase inverted at TR5 and then enters the differential circuit and the minus signal is cut at D3. These two signals are composited at D2, D3 cathodes and becomes twice the frequency generated at the detector coil.
- 4) The signal composited at Diodes D2, D3 is supplied to the base of TR6 as the TR6, TR7 one-shot multi vibrator trigger signal.
- 5) While the one-shot multi vibrator is stabilized, TR6 is turned off, TR7 is turned on, and no signal is emitted at TR7 collector.
- 6) When the positive trigger enters the base of TR6, and TR6 is turned on, TR7 "OFF", the one-shot multi vibrator reverses. TR7 collector voltage increases, and at the same time the charge current which has passed VR2, R59 (at 15 ips) flows to C10. When C10 electrical potential increases and TR7 is turned on, the collector voltage decreases. This operation is repeated by means of the trigger signal to TR6, and accordingly, a pulse output waveform is emitted at TR7 collector.
- 7) TR7 output is pulse regulated at TR8, TR9 and supplied to the integrated circuit and the output from the integrated circuit is supplied to the base of TR10.
- 8) Because the level of the signal which passed the integrated circuit is small, it is amplified at TR10, TR12, TR13.
- 9) Because the ripple part of the collector output signal from TR13 is considerable, it is further passed through the integrated circuit and supplied to the base of TR17.
- 10) TR17 and Power Transistor TR2 is conversion darlington connected, and TR2 is driven by TR17 emitter current and the impedance of TR2 between C-E is changed.

- 11) The supply voltage to the capstan motor is changed by the change in impedance between C-E of TR2 and the motor torque is also changed. At this time, a certain load is applied to the capstan motor. However, the voltage applied to the motor is changed according to this load. Therefore, the load is balanced with the torque and stabilized revolutions are maintained.

2. SPEED ADJUSTMENT SYSTEM

(Refer to Schematic Diagram)

- 1) In case the capstan motor revolutions become fast, the output signal frequency of the one-shot multi becomes high, the first integrated circuit output rises, TR10 is turned on further and the collector voltage decreases. When TR10 collector voltage is lowered, TR12 base bias decreases, and TR12 collector voltage rises. When TR12 collector voltage increases, TR13 collector output decreases and the second integrated circuit output voltage decreases. Consequently, TR17 base drive also decreases and the resistance between C-E of Power Transistor TR2 increases, the supply voltage to the motor decreases and the motor torque declines and capstan motor revolutions are reduced.
- 2) On the other hand, if the capstan revolutions become slow, the output signal frequency of the one-shot multi becomes low, the first integrated circuit output is lowered, TR10 is turned almost off, and the collector voltage increases. When TR10 collector voltage is increased, TR12 base bias increases, and TR12 collector voltage declines. When TR12 collector voltage decreases, TR13 collector output increases and the 2nd integrated circuit output voltage increases. Consequently, TR17 base drive also increases and the resistance between C-E of Power Transistor TR2 decreases, the supply voltage to the motor increases and the motor torque rises and capstan motor revolutions are increased.

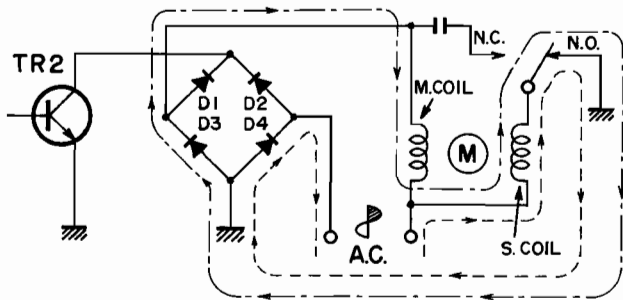

Fig. 37

3. RETARDER CIRCUIT OPERATION

When the Tape Speed Switch is switched from 15 ips to 7-1/2 ips, or from 7-1/2 ips to 3-3/4 ips, capstan motor revolutions are quickly decreased, and in a short time, established motor revolutions are attained.

- 1) When tape speed is switched from to 15 ips to 7-1/2 ips while switching is taking place, 15 ips revolutions are momentarily retained. The one-shot multi time constant becomes longer and the output pulse width wider. Consequently, the first integrated circuit output increases and in case the revolutions slightly increase over the aforementioned established revolutions, the D.C. amp. operates in the same way as explained above.
- 2) Accordingly, TR13 collector output decreases, and passes the 2nd stage integrated circuit. TR14 is turned off, TR15 "ON" and TR16 "ON". The collector current flow to relay at TR15 collector load, and the relay operates.
- 3) When the relay functions, the capstan motor sub coil is grounded, and an A.C. half wave flows as shown in the Fig. 37. The current within the negative half wave does not flow to Diode D4. The power generated at the sub coil passes the D3→main coil→sub coil closed circuit as shown in the Fig. 37. Consequently, a D.C. magnetic field is formed and braking is applied to the rotor of the motor.
- 4) When capstan motor revolutions decrease, the voltage necessary for normal revolutions appears at TR13 collector and TR14 is turned on. Also proper bias is applied to the base of TR17 and current flows to the motor through D2→TR2→D3→motor coil; motor coil→D1→TR2→D4, and normalized motor revolutions are attained.

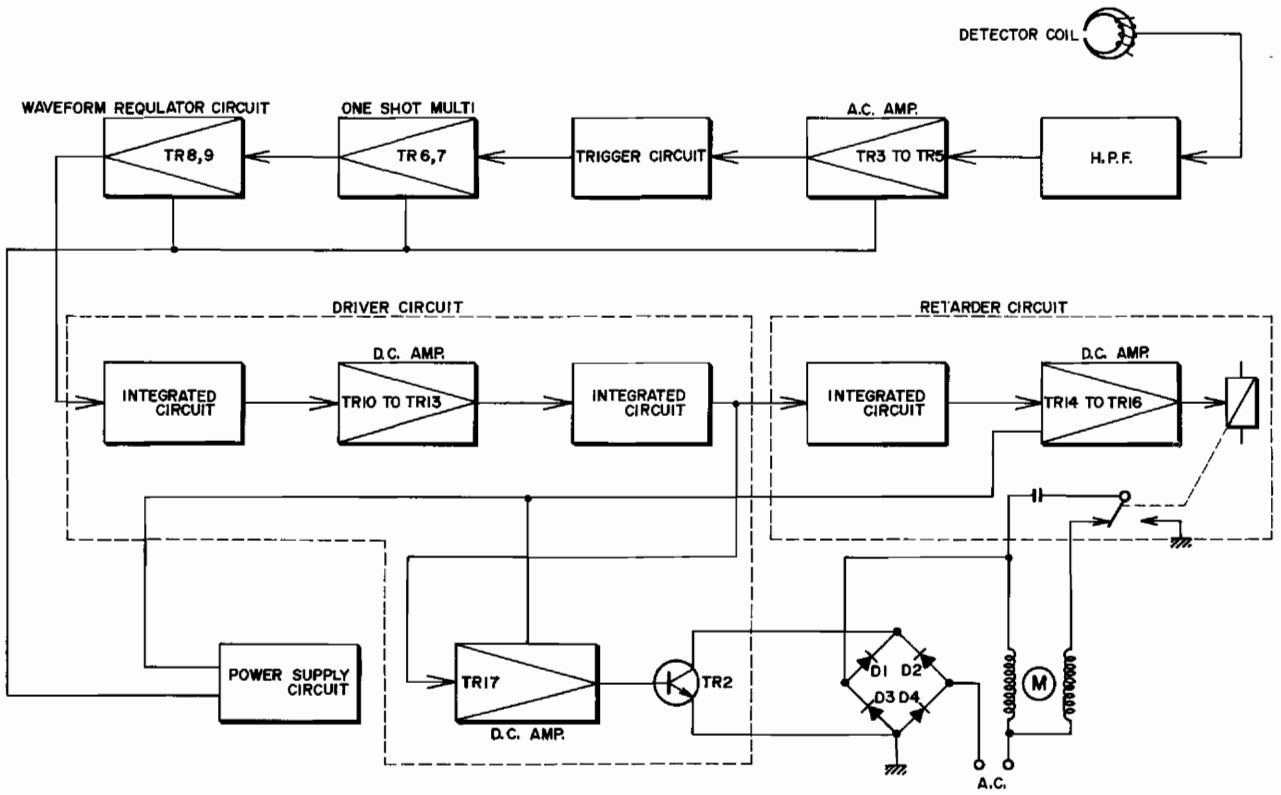
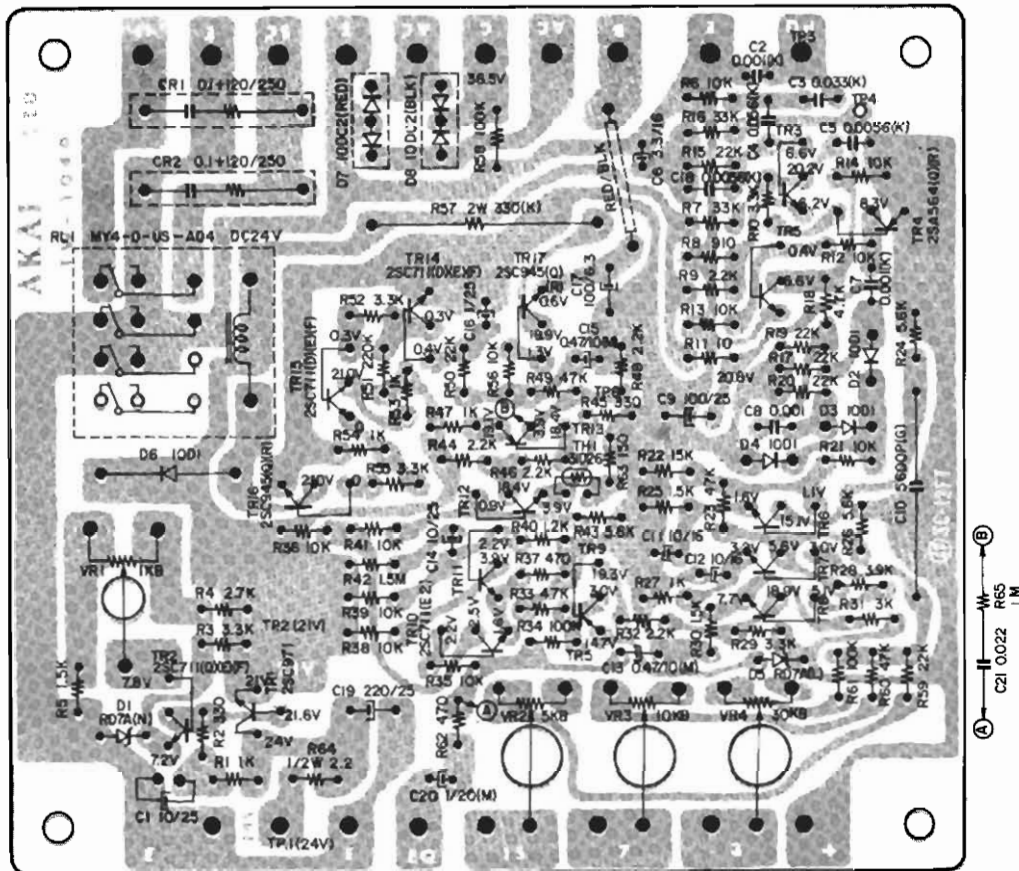

Fig. 38 A.C. SERVO CONTROL SYSTEM BLOCK DIAGRAM



TR3,5,6,7,8,12 2SC711(D)(E)(F)
 TR11 2SC711(E 2)
 TR9,13 2SA564(Q)(R)

Fig. 39 SERVO CONTROL P.C. BOARD TW-1049
 SERVO CIRCUIT TEST POINTS

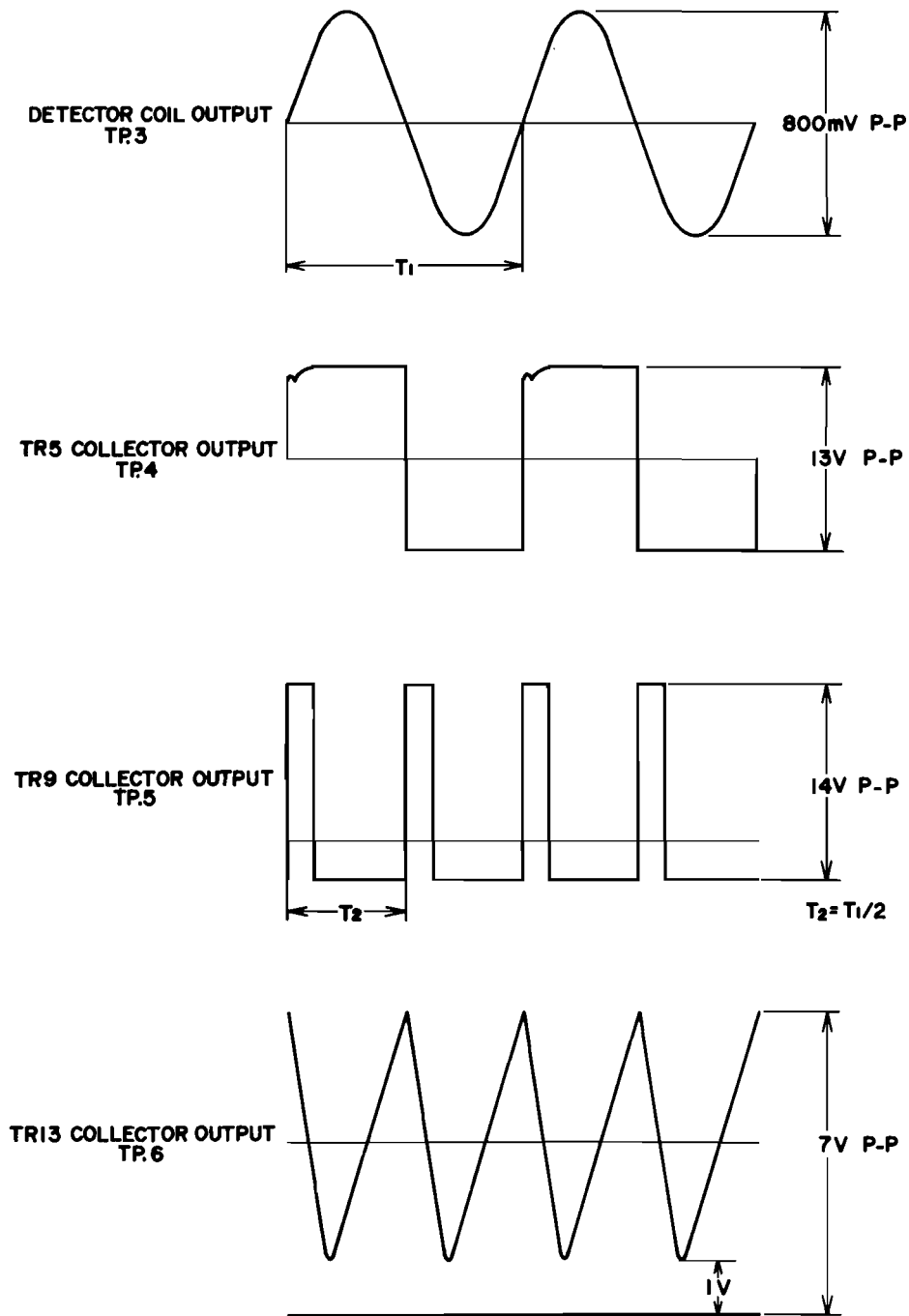

Fig. 40 Various Test Point Waveforms (at 15 ips tape speed)

IX. A.D.R. (AUTOMATIC DISTORTION REDUCTION) OPERATION

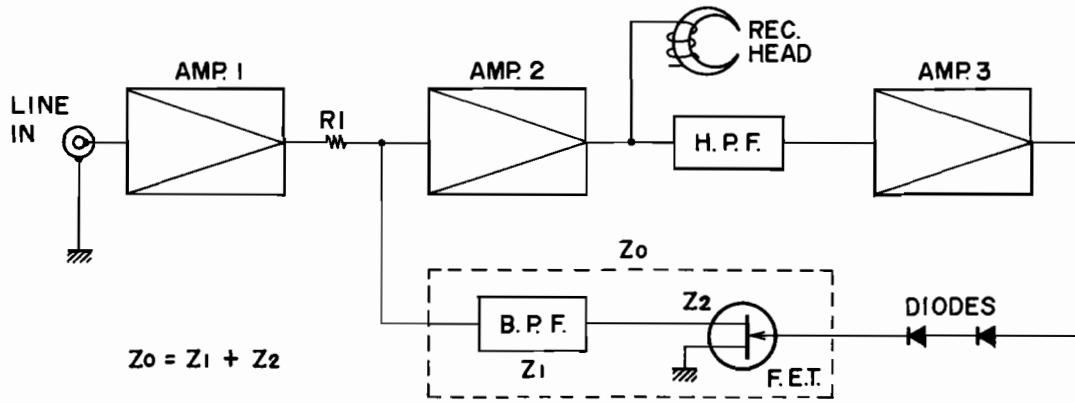

Fig. 41 A.D.R. BLOCK DIAGRAM

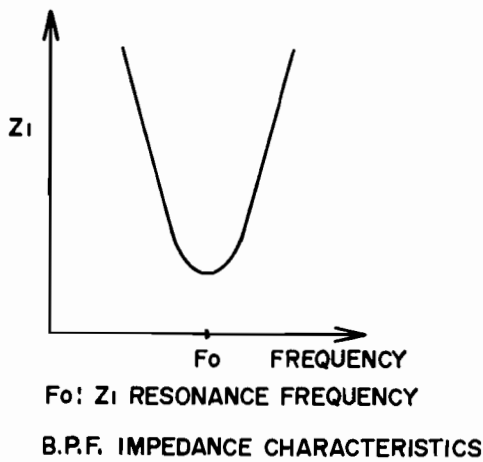

Fig. 42

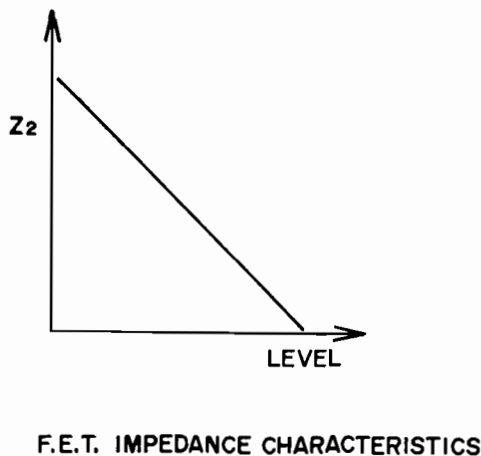
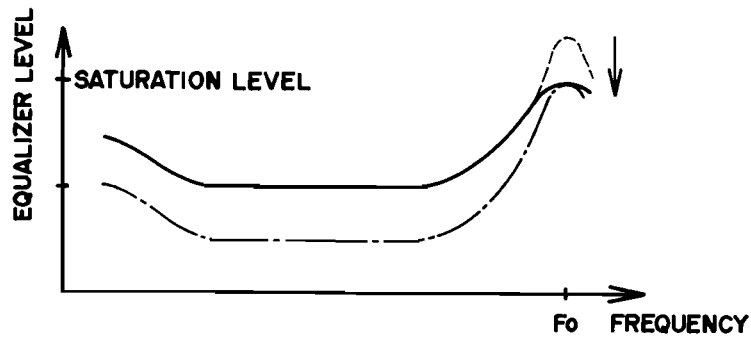

Fig. 43

1. The A.D.R. Block Diagram is as shown in Fig. 41, and A.T.T. is comprised of R_1 and Z_0 .
2. Z_0 impedance is the composite impedance of Z_1 of which the impedance is changed by the frequency and Z_2 which is changed depending upon the signal level. (See Figs. 42, 43)
3. Z_1 impedance resonates at recording equalizer peak point in the vicinity of f_0 (see Fig. 44). At resonance time the impedance of Z_1 is minimum.
4. When a flat and wide frequency band width signal is introduced to the Line Input, it is amplified at Amp. 1 and Amp. 2 and supplied to the recording head.
5. Regarding the flow of signal current to the Rec. Head, as shown in Fig. 44 when comparing the high with the low, the high flow of current is rather large.
6. Accordingly, in attempting to record at a high level, as shown in Fig. 44, there is a relative increase in the recording equalizer level as well, and there are instances in which the saturation level of the magnetic tape is surpassed at the equalizer peak.
7. At this time, as shown in Fig. 41, the Amp. 2 output passes the H.P.F., is amplified at Amp. 3, and this output is rectified at the diodes.
8. The voltage rectified at the diodes is supplied to the F.E.T. drain. Therefore, the impedance between gate & source is lowered and Z_0 impedance is also lowered. However, because at the resonance point vicinity of the recording equalizer Z_1 impedance is minimum, R_1 and Z_0 A.T.T. operates only at high range frequencies.
9. The high range frequency level is decreased at the input stage of Amp. 1 by means of A.T.T. composed of R_1 and Z_0 , and after passing Amp. 1 and Amp. 2, the recording current supplied to the recording head, as shown in Fig. 44, becomes below the saturation level of the magnetic tape in the vicinity of f_0 and the signal can be recorded on the magnetic tape without distortion.



RECORDING EQUALIZER CHARACTERISTICS

Fig. 44

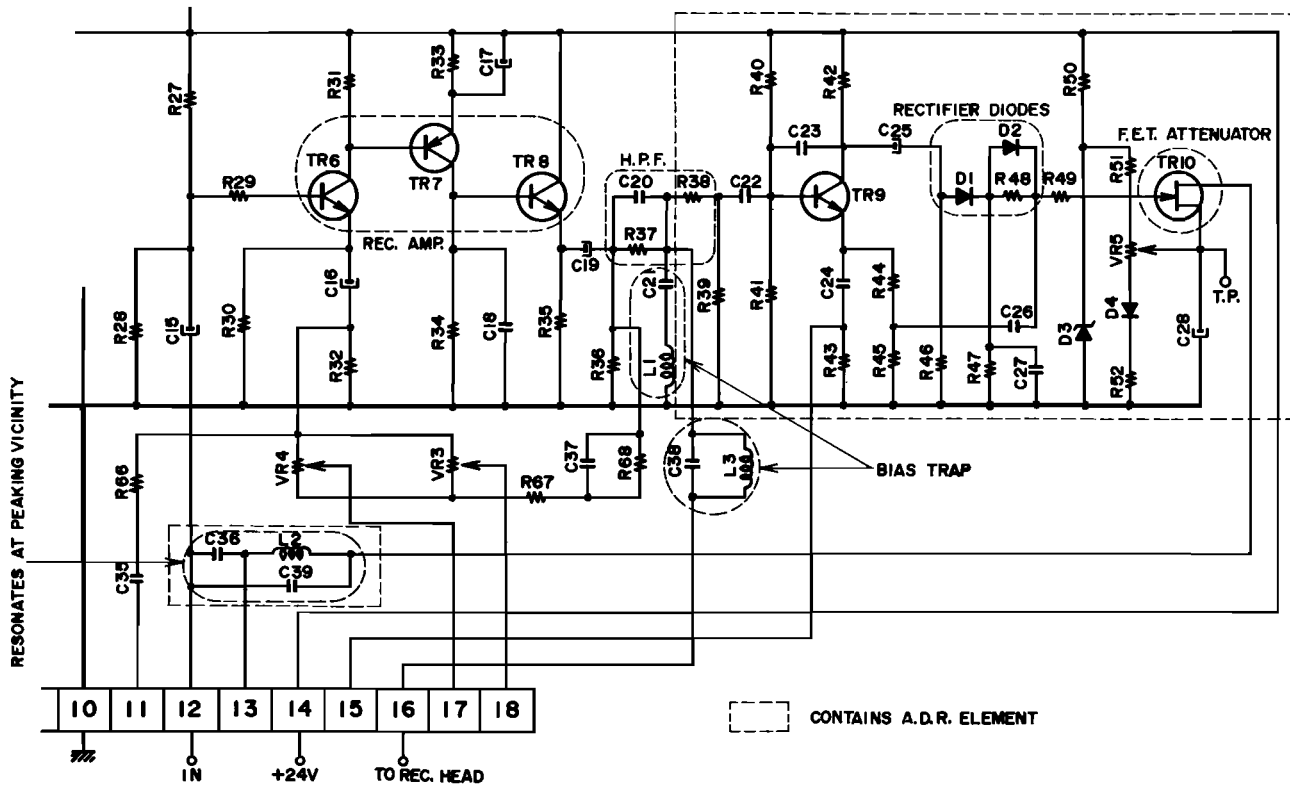

Fig. 45 A.D.R. SECTION SCHEMATIC DIAGRAM

X. TRANSPORT MECHANISM

1. MODEL: GX-400D

Mode		F-FWD	FWD	STOP	REV	RWD	FWD-REC	REV-REC
TRANSISTORS	TR1							
	TR2							
	TR3							
	TR4							
	TR5	○		○		○		
	TR6		○		○		○	○
	TR7	○	○	○		○	○	
	TR8				○			○
	TR9	○	○	○		○	○	
	TR10				○			○
	TR11				○			○
	TR12				△			
	TR13	○	○	○	○	○		
	TR14						○	○
	TR15		○	○	○	○	○	○
	TR16	○						
	TR17	○	○	○	○		○	○
	TR18					○		
	TR19	○		○	○	○		○
	TR20		○				○	
	TR21	○	○	○		○	○	
	TR22				○			○
	TR23	○	○	○	○	○		
	TR24						○	○
	TR25	○				○		
	TR26		○		○		○	○
	TR27				△			
RELAYS	RL1		△		△		△	△
	RL2	○				○		
	RL3				○	○		○
	RL4		○		○		○	○
	RL5				○		○	○
SOLENOID PLUNGERS	SL1	○	○		○	○	○	○
	SL2		○		○		○	○
	SL3		○		○		○	○

Relays

- RL1 T.D
- RL2 FAST
- RL3 R/R
- PL4 PLAY
- RL5 REV

Solenoid Plungers

- SL1 BRK
- SL2 P.L
- SL3 P.L

○ mark "engaged"
 △ mark "momentarily engaged"

Chart 6

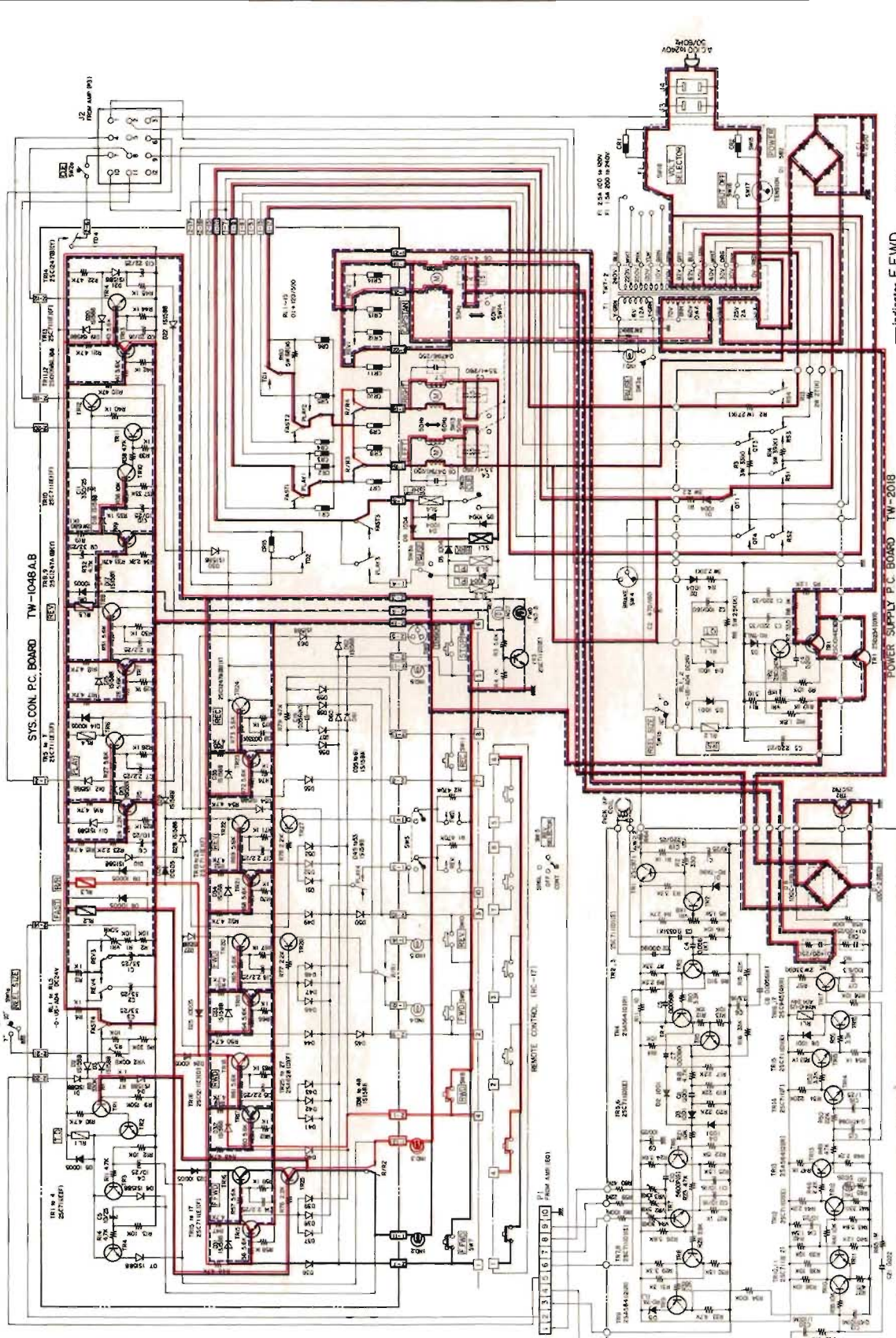

**GX-4000
SCHEMATIC DIAGRAM
NO. 2-2 1461251A**

— indicates F.FWD
- - - indicates RWD
— indicates STOP

NOTE: COMPONENTS SHOWN
ALL CAPACITORS IN µF UNLESS
OTHERWISE INDICATED
RESISTORS IN OHMS UNLESS
OTHERWISE INDICATED

SERVO CONTROL P.C. BOARD TW-1049

POWER SUPPLY P.C. BOARD TW-2018

2C

GX-4000

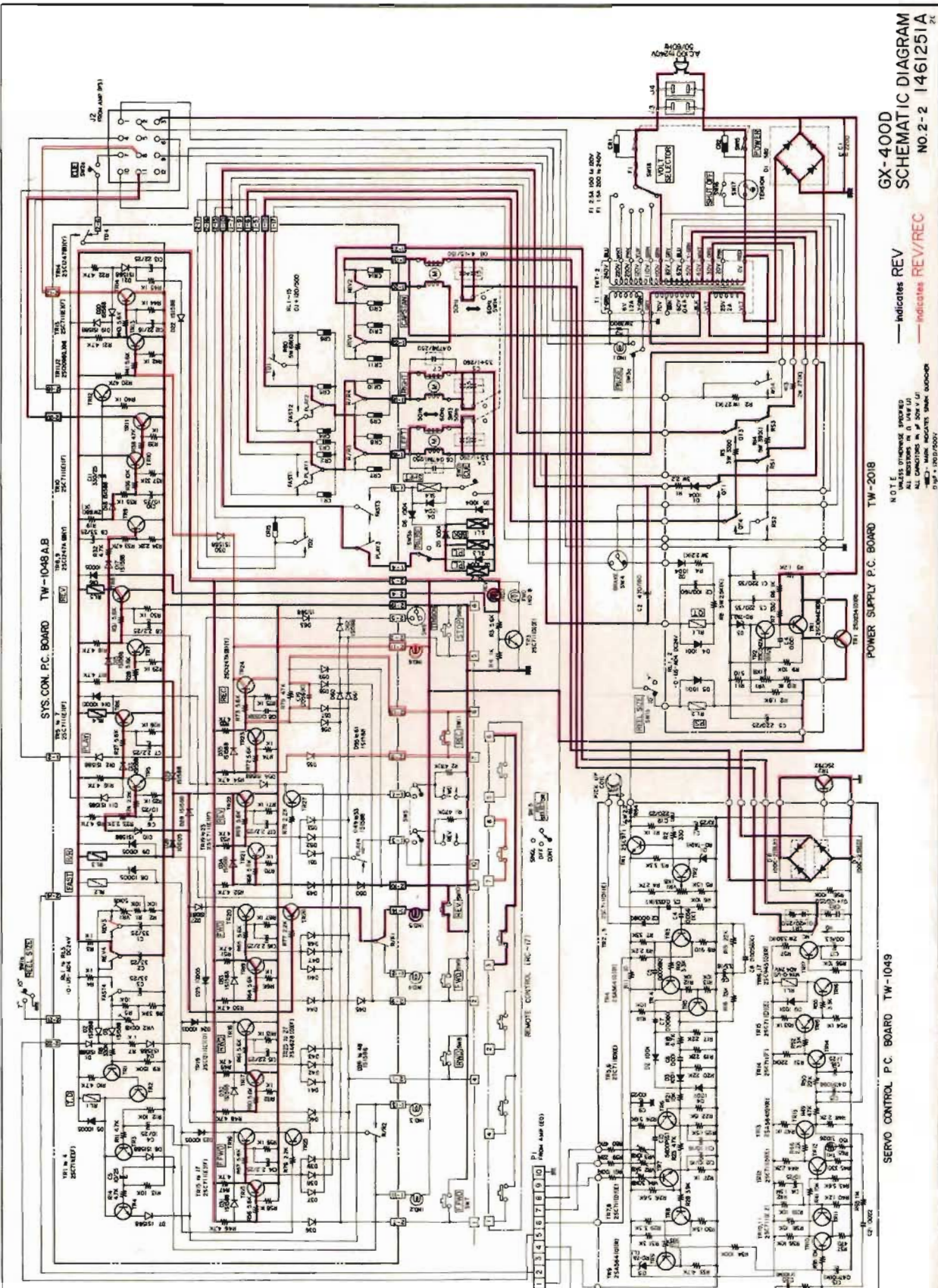

GX-4000
SCHEMATIC DIAGRAM
NO. 2-2 1461251A
2C

— indicates REV
— indicates REV/REC

NOTE:
ALL RESISTORS IN Ω UNLESS OTHERWISE SPECIFIED
ALL CAPACITORS IN μF UNLESS OTHERWISE SPECIFIED
— MARK INDICATES MARK GOOD FOR
DIP + 100/1000

POWER SUPPLY P.C. BOARD TW-2018

SERVO CONTROL P.C. BOARD TW-1049

2. MODEL: GX-400D PRO

Mode		F-FWD	FWD	STOP	RWD	REC
TRANSISTORS	TR1	○		○	○	
	TR2		○			○
	TR3	○	○	○	○	
	TR4					○
	TR5					
	TR6					
	TR7				△	
	TR8					
	TR9					
	TR10		○	○	○	○
	TR11	○				
	TR12	○	○	○		○
	TR13				○	
	TR14	○		○	○	
	TR15		○			○
	TR16	○	○	○	○	
	TR17					○
	TR18					
	TR19	○	○	○	○	○
	TR20				△	
RELAYS	RL1	○			○	
	RL2				○	
	RL3		○			○
	RL4		△			
SOLENOID PLUNGERS	SL1	○	○		○	○
	SL2		○			○
	SL3		○			○

Relays
 RL1 FAST
 RL2 RWD
 RL3 FWD
 RL4 T.D

Solenoid Plungers
 SL1 BRK
 SL2 P.L
 SL3 P.L

○ mark "engaged"
 △ mark "momentarily engaged"

Chart 7

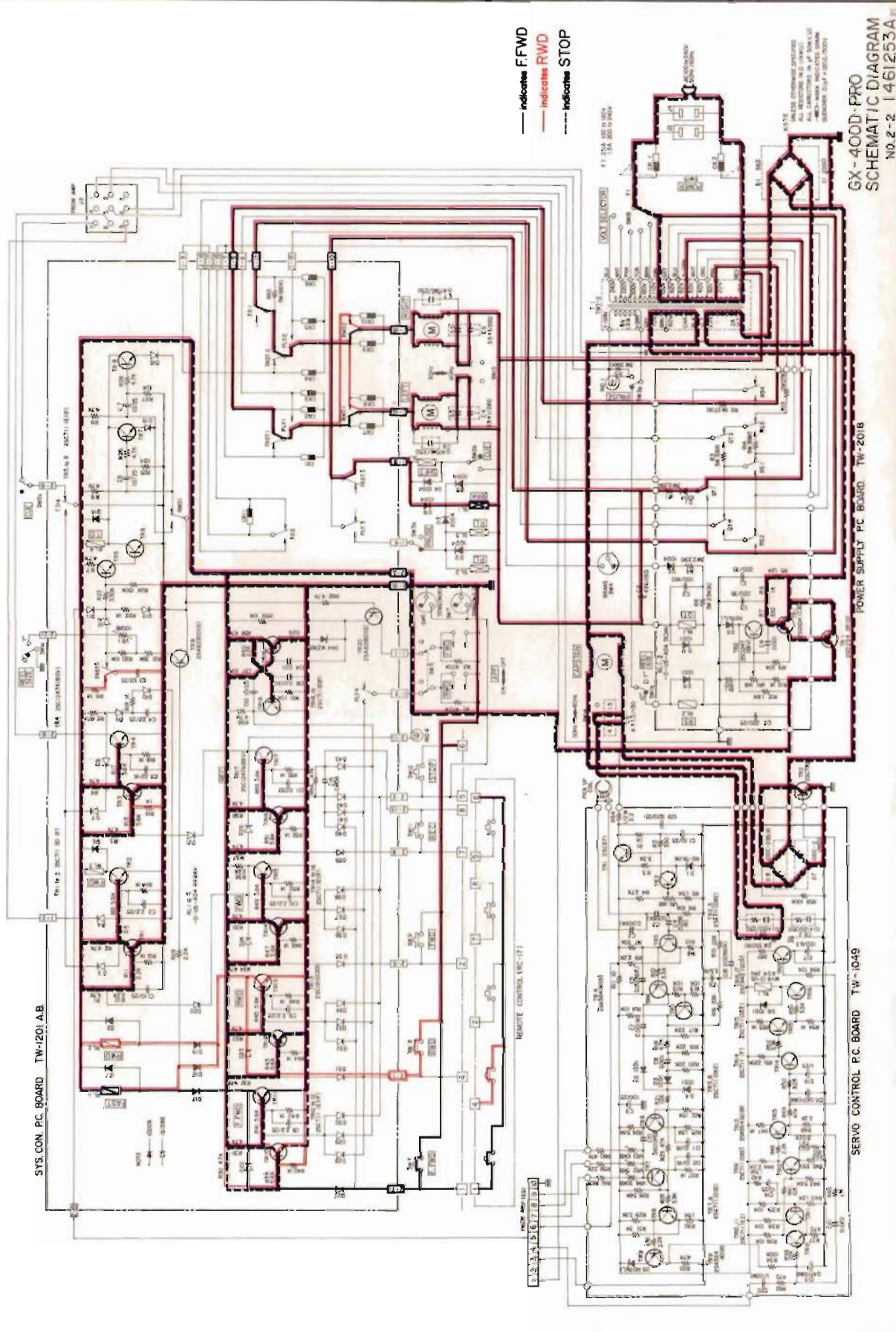

GX-4000-PRO
SCHEMATIC DIAGRAM
NO. 2-2 1461253A

XI. D.C. RESISTANCE OF EACH COIL

D.C. resistance value is average value.

Designation	Type	D.C. Resistance
CAPSTAN MOTOR	SCM3-16TW	Between RED-BLU 19Ω Between YLW-GRN 90Ω
REEL MOTOR	IM1-24TW	Between RED-BLU 30Ω Between YLW-GRN 157Ω
PINCH ROLLER SOLENOID	1660PHT2	750Ω
BRAKE SOLENOID	1660THT2	700Ω
SHIFTER SOLENOID	1254THT	620Ω
REV SOLENOID	1660PHT	45Ω & 200Ω
PICK UP COIL	Built into CAPSTAN MOTOR	3.7 kΩ
COMBO HEAD	RE4-6	(REC) 5.5Ω (ERASE) 2.3Ω
4 TRACK P.B. HEAD	P4-220	160Ω
2 TRACK P.B. HEAD	P2-100	250Ω
2 TRACK REC HEAD	R2-100	8Ω
FULL TRACK ERASE HEAD	EF-210	2.8Ω
RELAY	O-US-AD4 D.C.24V	650Ω
RELAY	TECK-36	1,000Ω
HEAD PHONE TRANS.	N19-228S 7.5 kΩ:8Ω	(Primary) 580Ω (Secondary) 1Ω
POWER TRANS.	TWT-2	Refer to Fig. 46

Chart 8

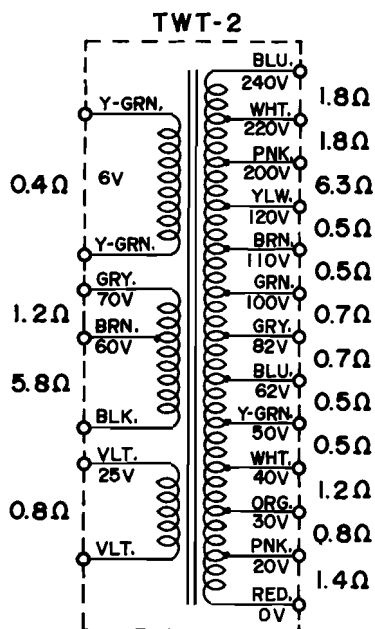
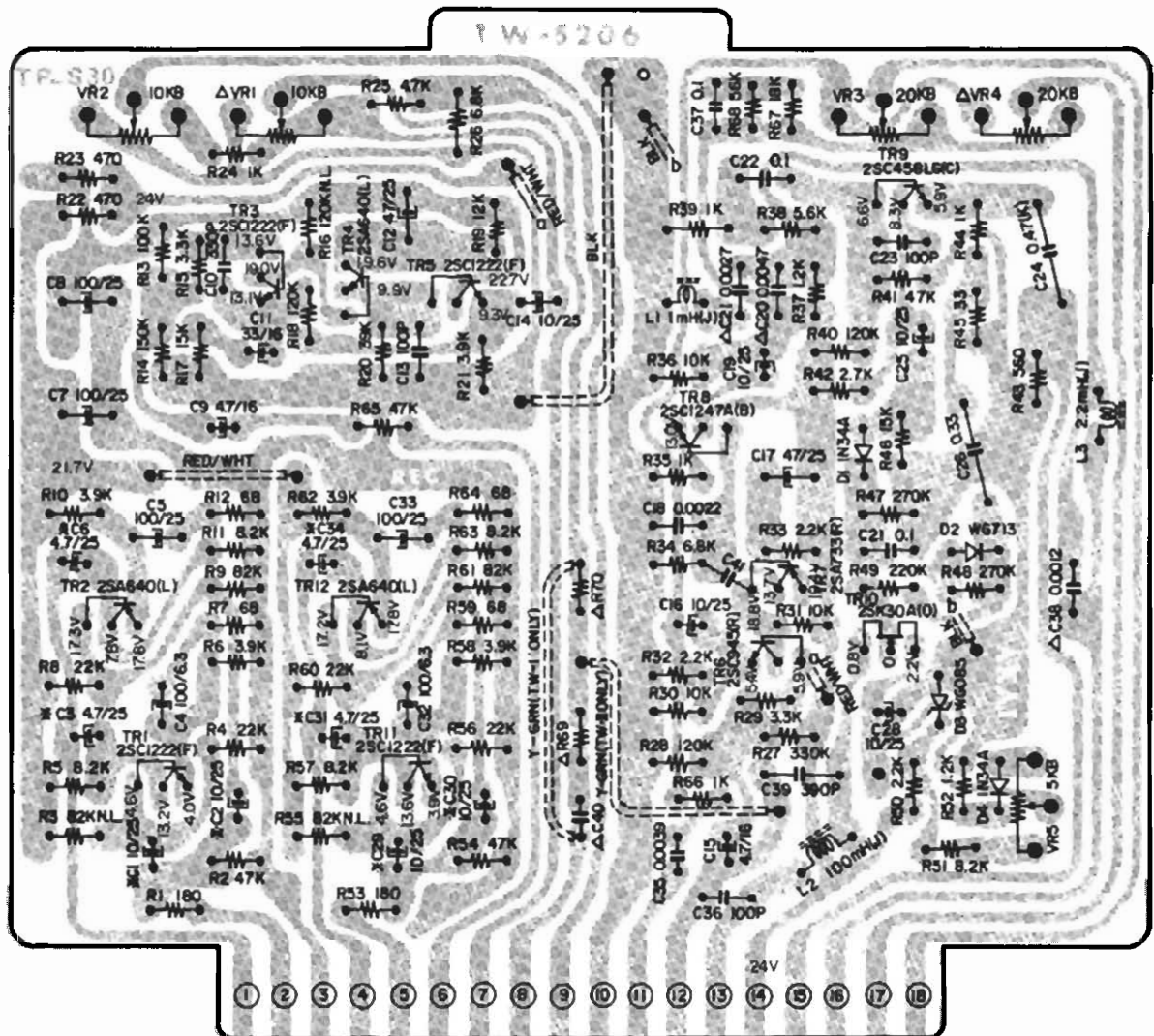

Fig. 46

XII. COMPOSITE VIEWS OF COMPONENTS

1. REC. AMP. P.C. BOARD TW-5206



NOTE

	△ C20	C21	C38	C40	C41	R69	R70	VR1	VR4
TW-I	0.0047	0.0027	0.0012	/	/	/	/	USED	USED
TW-II	0.0056	0.001	430P	0.0027	82P	4.7K	10K	/	/

3. OSC. P.C. BOARD TW-5033

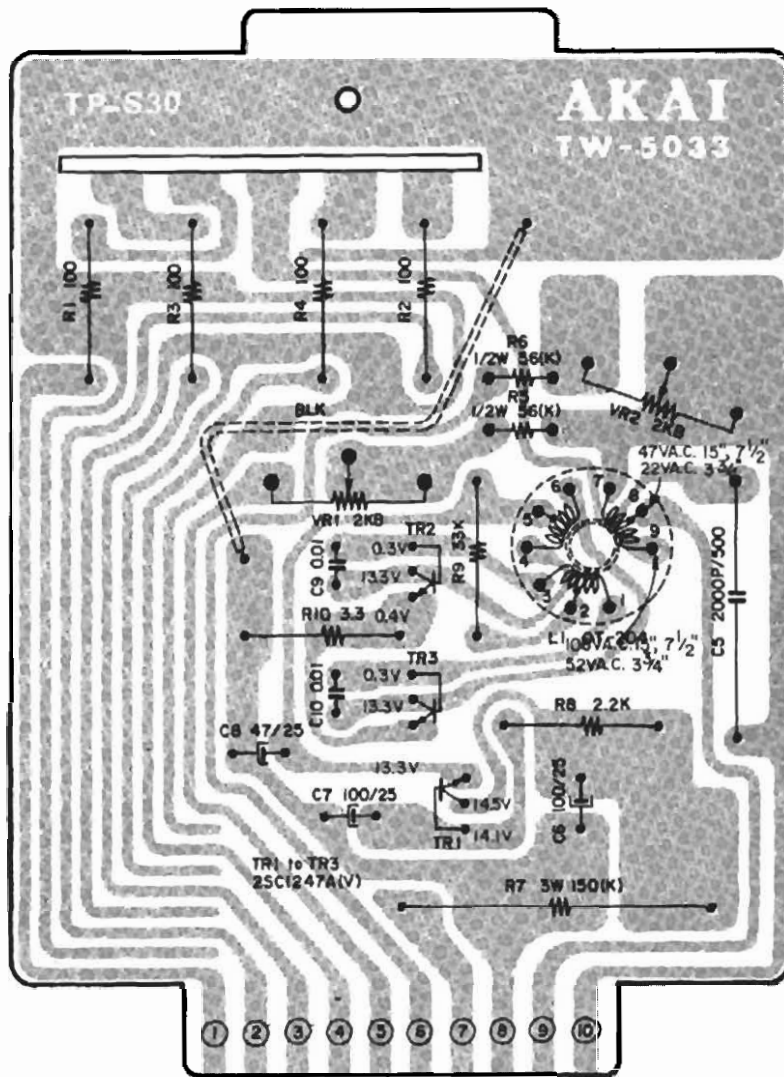
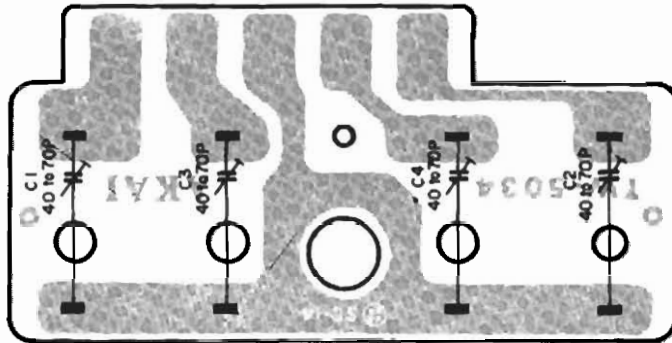

4. OSC. P.C. BOARD TW-5204 (PRO)

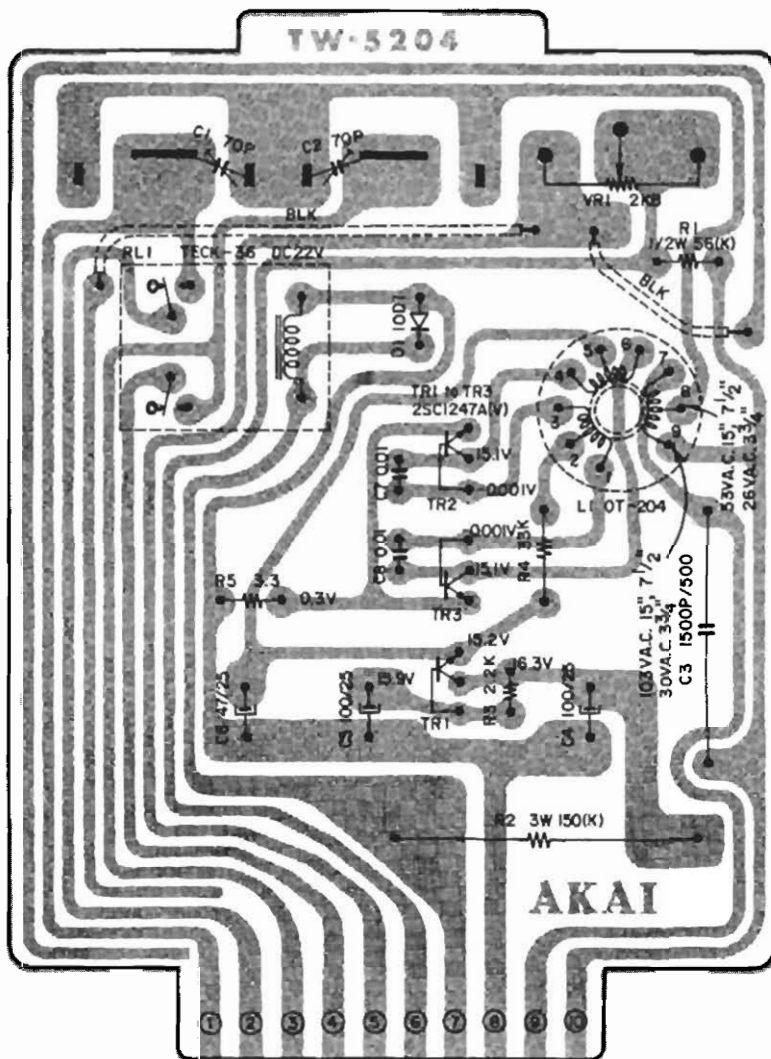

5. SYS. CON. P.C. BOARD TW-1048

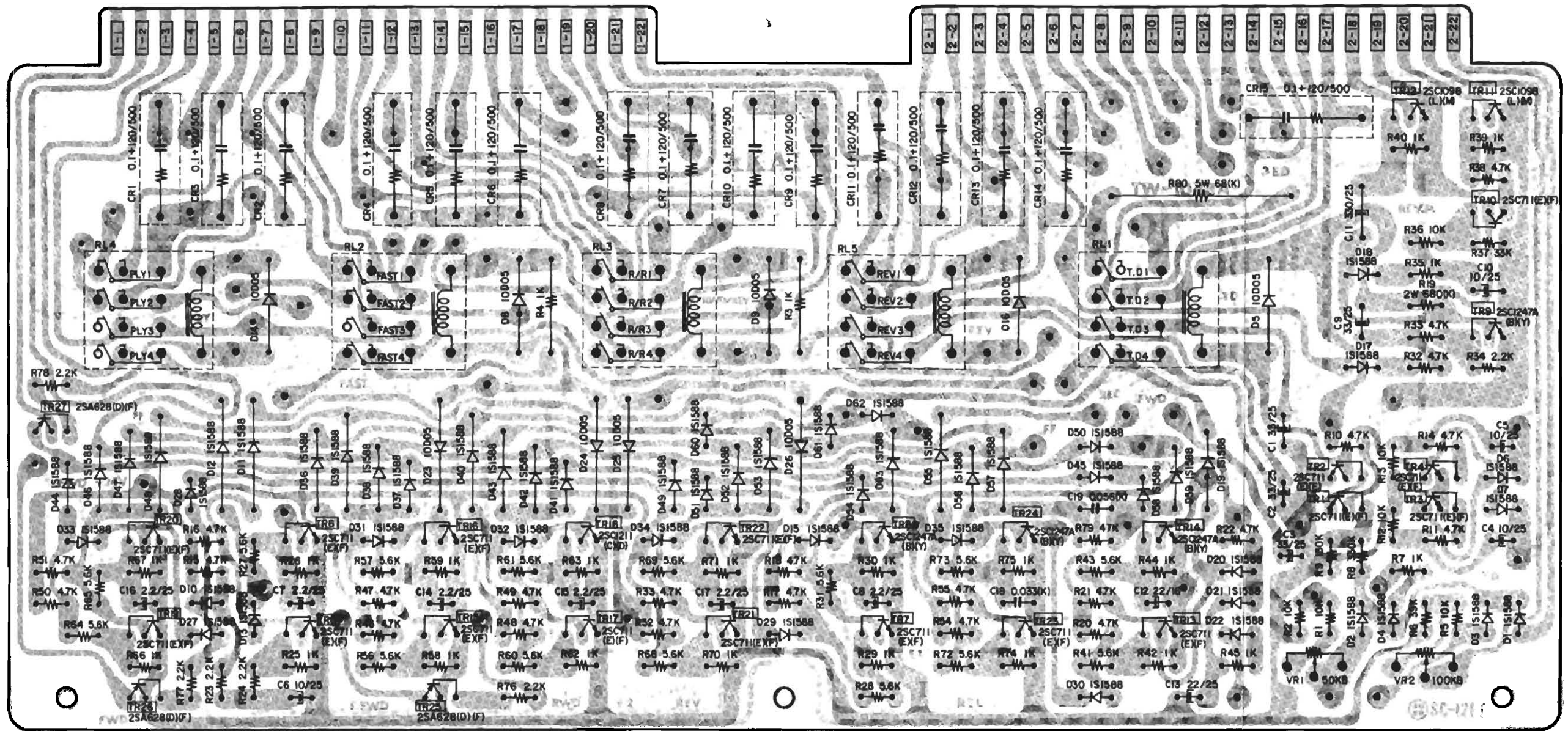

	TR1	TR2	TR3	TR4	TR5	TR6	TR7	TR8	TR9	TR10	TR11	TR12	TR13	TR14
E										16.7V(F,F,REV,REC) 0(OTHER)				
C	24V	24V	24V	24V	0.1V(FWD,STOP,RWD) 13V(OTHER)	24V(F,F,STOP,RWD) 0.1V(OTHER)	10V(REV,REC) 0.1V(OTHER)	0.3V(REV,REC) 23.3V(OTHER)	23.6V(REV,REC) 0.1V(OTHER)	24V	0.2V(F,F,REV,REC) 35V(OTHER)	34V(REV,REC) 36V(OTHER)	14.3V(REC) 0.1V(OTHER)	0.2V(REC) 24V(OTHER)
B					0.4V(FWD,STOP,RWD) 0.8V(OTHER)	0.8V(FWD,REV,REC) 0.1V(OTHER)	0.2V(REV,REC) 0.8V(OTHER)	0.8V(REV,REC) 0.1V(OTHER)	0.1V(REV,REC) 0.8V(OTHER)	18V(F,F,REV,REC) 0(OTHER)	0.8V(F,F,REV,REC) 0(OTHER)		0.2V(REC) 0.8V(OTHER)	0.8V(REC) 0(OTHER)
	TR15	TR16	TR17	TR18	TR19	TR20	TR21	TR22	TR23	TR24	TR25	TR26	TR27	
E											2.2V(F,F,RWD) 24V(OTHER)	2.3V(FWD,REV,REC) 24V(OTHER)	10V(REV,REC) 0.1V(OTHER)	
C	13.4V(F,F) 0.1V(OTHER)	0.2V(F,F) 23.6V(OTHER)	13.3V(RWD) 0.1V(OTHER)	0.2V(RWD) 23.6V(OTHER)	13.3V(FWD,REL) 0.1V(OTHER)	0.1V(FWD,REC) 10V(REV,REC) 23V(OTHER)	10V(REV,REC) 0.1V(OTHER)	0.3V(REV,REC) 23.6V(OTHER)	13.4V(REC) 0.1V(OTHER)	0.2V(REC) 24V(OTHER)				
B	0.2V(F,F) 0.8V(OTHER)	0.8V(F,F) 0.1V(OTHER)	0.2V(RWD) 0.8V(OTHER)	0.8V(RWD) 0.1V(OTHER)	0.2V(FWD,REC) 0.8V(OTHER)	1V(F,F,FWD,REC) 0.1V(OTHER)	0.2V(REV,REC) 1V(OTHER)	0.9V(REV,REC) 0.1V(OTHER)	0.2V(REC) 1V(OTHER)	0.8V(REC) 0.1V(OTHER)	1.5V(F,F,RWD) 24V(OTHER)	23V(F,F,RWD,STOP) 2V(OTHER)	24V(F,F,STOP,RWD) 0.1V(OTHER)	

6. SYS. CON. P.C. BOARD TW-1201 (PRO)

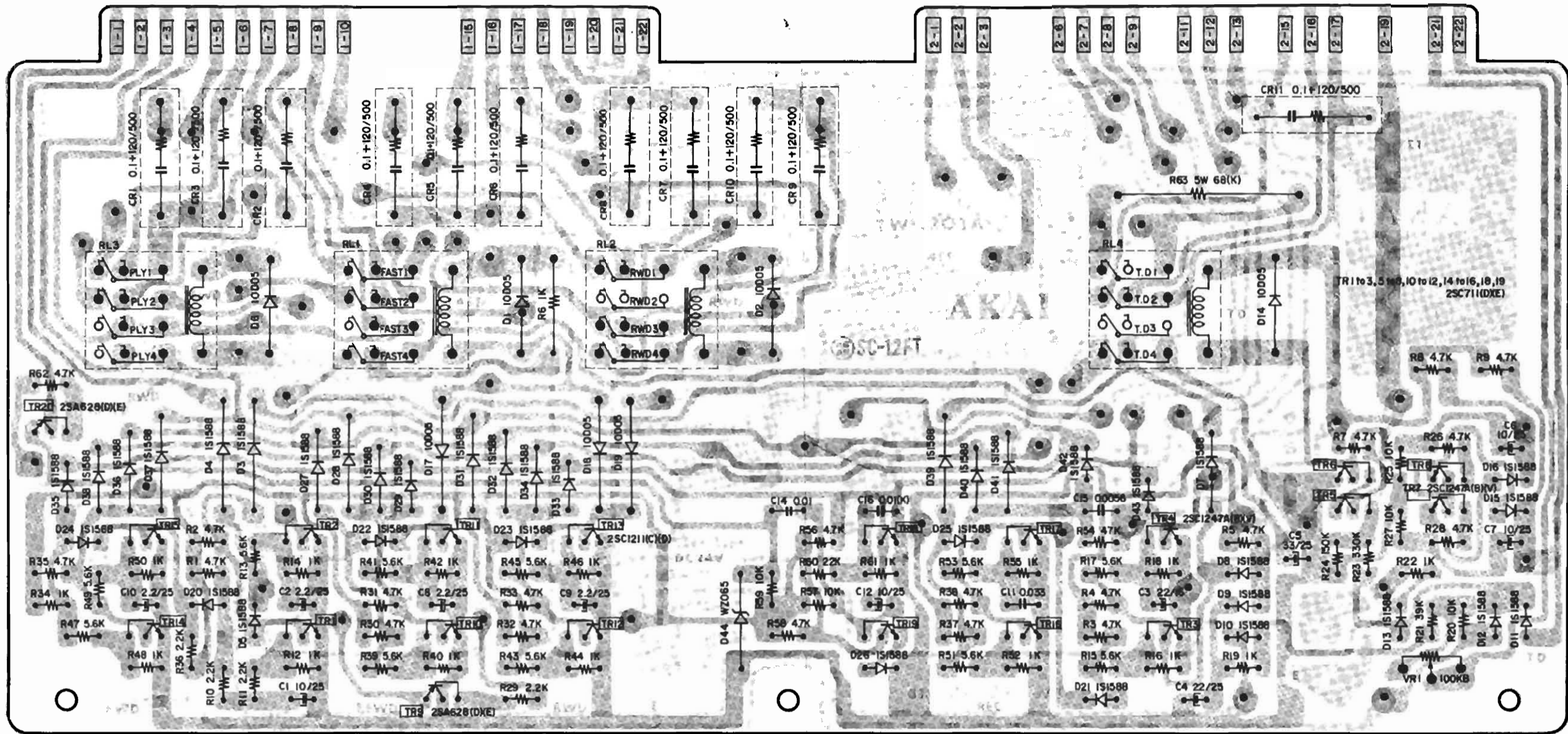

	TR1	TR2	TR3	TR4	TR5	TR6	TR7	TR8	TR9	TR10	TR11	TR12	TR13	TR14	TR15	TR16	TR17	TR18	TR19	TR20	
E																					6.2V
C	12V(FWD,REC) 0.1V(OTHER)	0.2V(FWD,REC) 24V(OTHER)	14.4V(REC)- 0.1V(OTHER)	0.1V(REC) 24V(OTHER)	24V	24V	24V	24V		13.4V(F.F) 0.1V(OTHER)	0.2V(F.F) 23V(OTHER)	13.5V(RWD) 0.1V(OTHER)	0.1V(RWD) 23.6V(OTHER)	13.3V(FWD,REC) 0.1V(OTHER)	0.1V(FWD,REC) 24V(OTHER)	13.3V(REC) 0.1V(OTHER)	0.1V(REC) 24V(OTHER)	24V	0.8V		6.2V(F.F,RWD) 0.1V(OTHER)
B	0.2V(FWD,REC) 0.8V(OTHER)	0.8V(FWD,REC) 0.1V(OTHER)	0.1V(REC) 0.8V(OTHER)	0.8V(REC) 0.1V(OTHER)						0.2V(F.F) 0.7V(OTHER)	0.8V(F.F) 0.1V(OTHER)	0.2V(RWD) 0.8V(OTHER)	0.8V(RWD) 0.1V(OTHER)	0.2V(FWD,REC) 0.8V(OTHER)	0.8V(FWD,REC) 0.1V(OTHER)	0.2V(REC) 0.8V(OTHER)	0.8V(REC) 0.1V(OTHER)	0.3V	1.5V		5.5V(F.F,RWD) 17.5V(OTHER)

SECTION 2

PARTS LIST

TABLE OF CONTENTS

FIG. 1	TW HEAD BLOCK	56
FIG. 2	MAIN MOTOR (SCM-16TW) BLOCK	58
FIG. 3	REEL MOTOR & REEL TABLE BLOCK	59
FIG. 4	FLYWHEEL & PINCH ROLLER ARM BLOCK	60
FIG. 5	TENSION ARM & DAMPER BLOCK	62
FIG. 6	OPERATION BLOCK	64
FIG. 7	MECHANISM ASSEMBLY BLOCK	66
FIG. 8	POWER SUPPLY BLOCK	68
FIG. 9	SERVO P.C. BOARD (TW-1049) BLOCK	70
FIG. 10	SYS. CON. P.C. BOARD (TW-1048) BLOCK	72
FIG. 11	SYS. CON. P.C. BOARD (TW-1201) BLOCK (GX-400D PRO)	74
FIG. 12	P.B. AMP. P.C. BOARD (TW-5032) BLOCK	76
FIG. 13	REC. & ADR P.C. BOARD (TW-5206) BLOCK	77
FIG. 14	OSC. P.C. BOARD (TW-5033) BLOCK	79
FIG. 15	OSC. P.C. BOARD (TW-5204) BLOCK (GX-400D PRO)	79
FIG. 16	DIRECTION P.C. BOARD (TW-2057) BLOCK	80
FIG. 17	POWER SUPPLY P.C. BOARD (TW-2018) BLOCK	80
FIG. 18	EQUALIZER SWITCH P.C. BOARD (TW-5028) BLOCK	81
FIG. 19	T.S. P.C. BOARD (TW-5026) BLOCK	81
FIG. 20	P.B. MODE P.C. BOARD (TW-5203) BLOCK	81
FIG. 21	MONITOR SWITCH P.C. BOARD (TW-5027) BLOCK	82
FIG. 22	SRT SWITCH P.C. BOARD (TW-5029) BLOCK	82
FIG. 23	CHASSIS P.C. BOARD (TW-5025) BLOCK	83
FIG. 24	AMPLIFIER ASSEMBLY BLOCK	84
FIG. 25	FINAL ASSEMBLY BLOCK	86
INDEX		88

HOW TO USE THIS PARTS LIST

1. This parts list is compiled by various individual blocks based on assembly process.
2. When ordering parts, please describe parts number, serial number, and model number in detail.
3. How to read list.

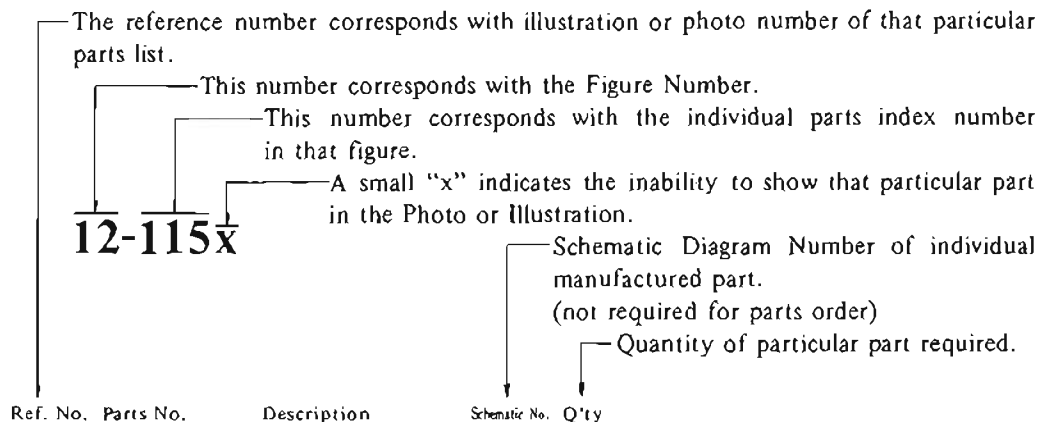

Ref. No.	Parts No.	Description	Schematic No.	Q'ty
FLYWHEEL BLOCK #13				
12-115x	800425	Flywheel Block Assy. Comp.	RUG #13	1
12-116	244506	Flywheel Only	RD-233	1
12-117x	244754	Felt, Flywheel	RD-235	1
12-118	251324	Main Metal Case	RD-236	1
12-119	253080	Main Metal	RD-237	1

4. The symbol numbers shown on the P.C. Board list can be matched with the Composite Views of components of the Schematic Diagram or Service Manual.
5. The indications of Resistors and Capacitors in the photos of P.C. Board are being eliminated.
6. The shape of the parts and parts name, etc. can be confirmed by comparing them with the parts shown on the Electrical Parts Table of P.C. Board.
7. Both the kind of part and installation position can be determined by the Parts Number. To determine where a parts number is listed, utilize Parts Index at end of Parts List.
It is necessary first of all to find the Parts Number. This can be accomplished by using the Reference Number listed at right of parts number in the Parts Index. (meaning of ref. no. outlined in Item 3 above).
8. Utilize separate "Price List for Parts" to determine unit price. The most simple method of finding parts Price is to utilize the reference number.

ELECTRICAL PARTS TABLE



<p>Because the indication of resistors and capacitors in the P. C. Board photos are being eliminated, please confirm parts name and shape by comparing them with the parts shown in this table.</p>	<p>1  Solid Resistor</p>	<p>2  Insulator Type Carbon Resistor</p>	<p>3  Metal Oxide Film Resistor</p>
<p>4  Cement Resistor</p>	<p>5  Wire-Wound Resistor</p>	<p>6  Thermister</p>	<p>7  Enamel Resistor</p>
<p>1  MP Capacitor (Tubular Type)</p>	<p>2  Plastic Capacitor</p>	<p>3  Mylar Capacitor</p>	<p>4  VFM (Hi-Q) Capacitor</p>
<p>5  Mylar Capacitor</p>	<p>6  Tantalum Capacitor</p>	<p>7  Oil Capacitor (Tubular Type)</p>	<p>8  Vertical Type Tubular Type Styroil Capacitor</p>
<p>9  Electrolytic Capacitor (Tubular Type)</p>	<p>10  Vertical Type Tubular Type Electrolytic Capacitor</p>	<p>11  Ceramic Capacitor</p>	<p>12  Metalized Mylar (Paper) Capacitor</p>
<p>13  Trimmer Condenser</p>		<p>VR  Semi-Fixed Volume</p>	
<p>L  Ferri Inductor</p>	<p>TR  Transistor</p>		
<p>CR  Spark Quencher</p>	<p>D  Diode (Silicon, Zener, Germanium)</p>		

FIG. 1 ILLUSTRATION OF TW HEAD BLOCK

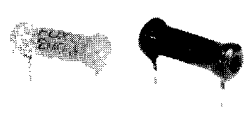

TW HEAD BLOCK

Ref. No.	Parts No.	Description	Schematic No.	Q'ty
1-1x	BH552172	TW Head Block Comp.	TW-1	1
1-2x	BH552183	TW Head Block Comp. (PRO)	TW-2	1
1-3	HZ532664	Head Base A	TW-0001	1
1-4	HZ532675	Head Base B	TW-0002	1
1-5	HZ532776	Shield Case	TW-0011	2
1-6	HZ532765	PH Retaining Base	TW-0010	2
1-7	HZ532743	CH Angle A	TW-0009	1
1-8	HZ532754	CH Angle B	TW-0009	1
1-9	HZ532732	CH Retaining Base	TW-0008	2
1-10	HZ532708	Tape Guide A	TW-0005	2
1-11	HZ532697	Tape Guide Prop A	TW-0004	1
1-12	HZ532710	Tape Guide B	TW-0006	1
1-13	HZ532686	Head Base Prop A	TW-0003	3
1-14	HZ532721	Double-end Screw Prop	TW-0007	2
1-15	HP552194	P.B. HEAD P4-220	TW	2
1-16	HR556582	REC./ERASE HEAD RE4-6	TW-1	2
1-17x	HP552205	P.B. HEAD P2-100 (PRO)	TW-2	1
1-18x	HR552216	REC. HEAD R2-100 (PRO)	TW-2	1
1-19x	HE552914	ERASE HEAD EF-210 (PRO)	TW-2	1
1-20x	HZ533597	RH Angle (PRO)	TW-0201	1
1-21x	HZ533608	EH Angle (PRO)	TW-0202	1
1-22	ZW477876	Screw, pan head 2x3		8
1-23x	HZ540573	Terminal P.C. Board C	RD-A36	4
1-24	ZW537006	Screw, binding head 4x8		9
1-25	ZW536490	Screw, binding head 3x12		12
1-26	ZW396000	Screw, binding head 3x4		8
1-27	ZW430863	Washer (SPC)D3.3x6x0.5t		8
1-28	ZG540584	Angle Adjust Spring G	TW-0025	6
1-29	ZG364656	Angle Adjust Spring C	RD-57	6
1-30x	ZG382757	Angle Adjust Spring D (PRO)	RD-A12	3
1-31	ZG466312	Angle Adjust Spring E	BS-0018	1
1-32x	EZ432088	Nylon Clip HP-6N	2-7-40	1
1-33x	EA382713	Head Connector P.C. Board	RD-A8	1
1-34x	EA222096	Connector P.C. Board	RD-140	1
1-35x	EA432088	Nylon Clip HP-6N (PRO)	2-7-40	1
1-36	ZW516993	Nut M3		2
1-37	ZW416698	Nut M4		2

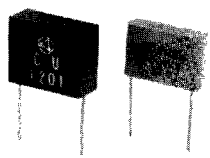
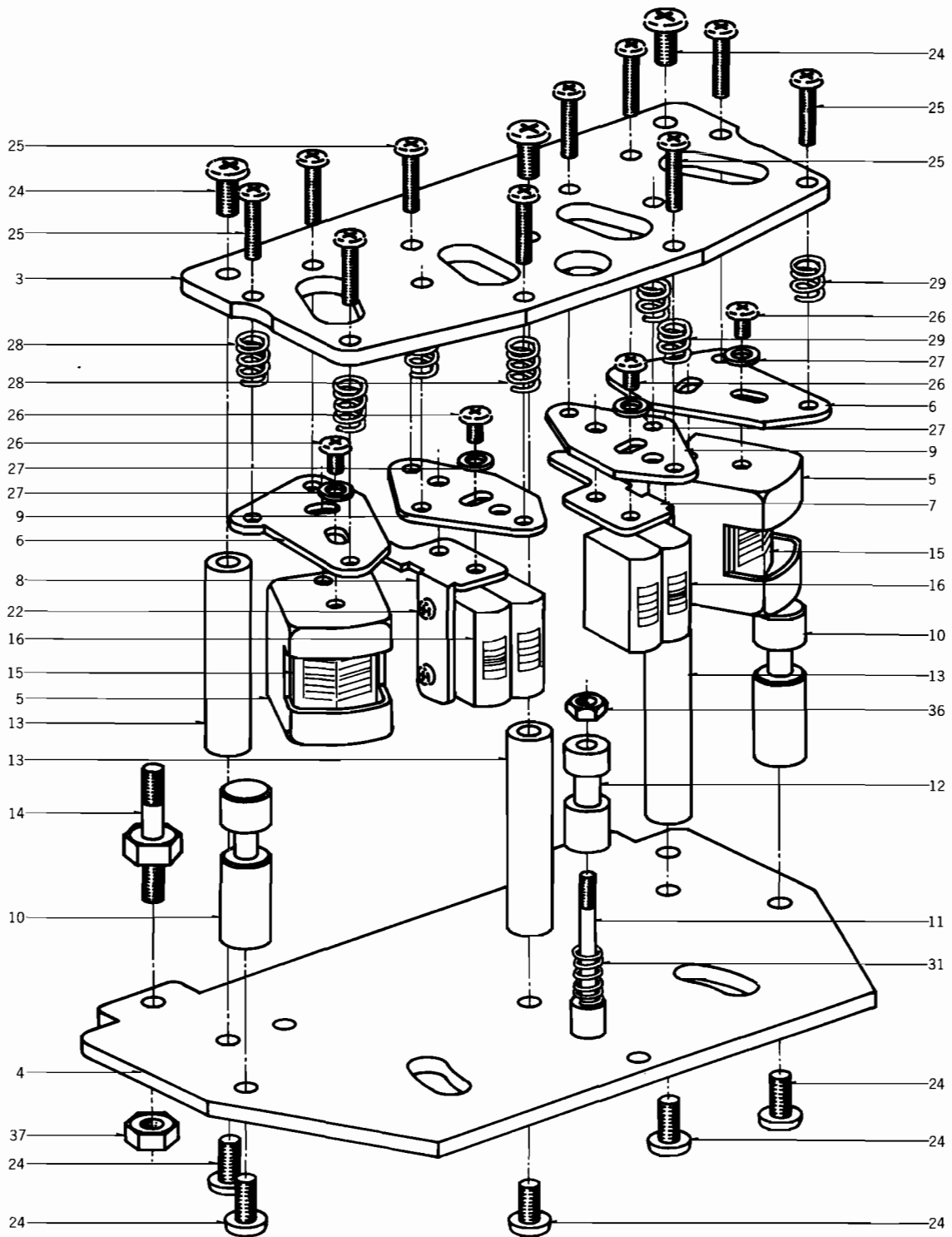
FIG. 2 ILLUSTRATION OF MAIN MOTOR BLOCK

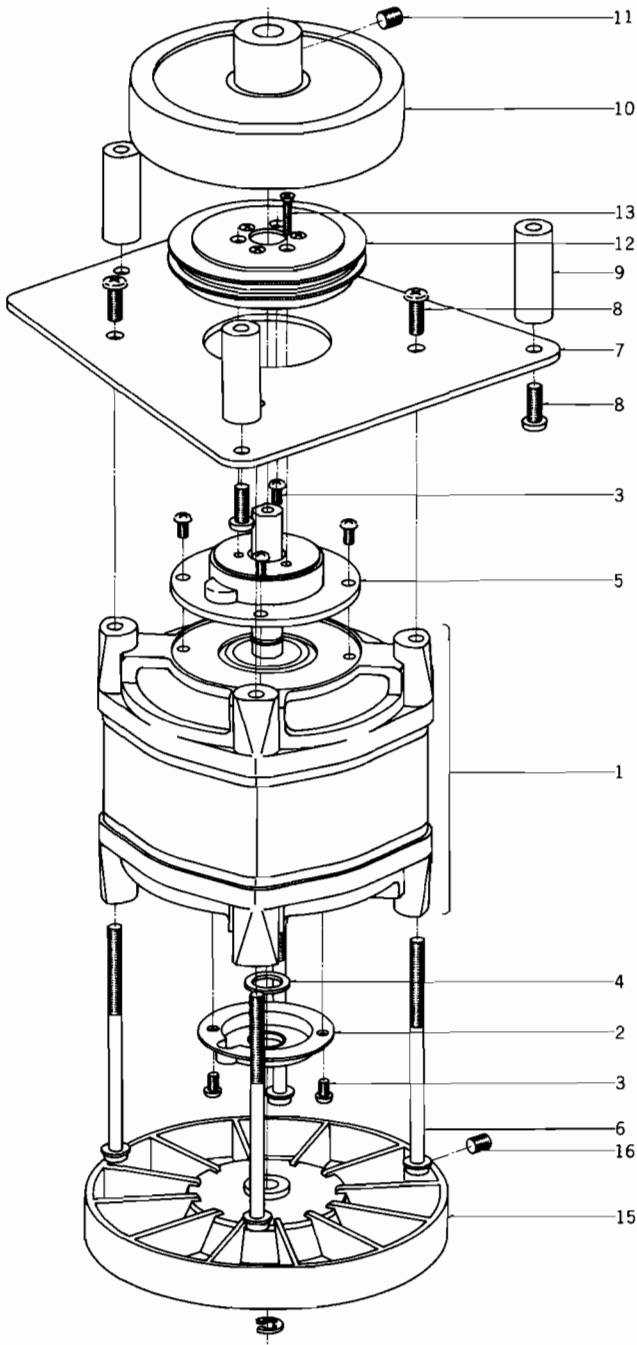

MAIN MOTOR (SCM3-16TW) BLOCK

Ref. No.	Parts No.	Description	Schematic No.	Q'ty
2-1	BM552148	Main Motor (SCM3-16TW) Block Comp.	TW	1
2-2	ZW459167	48 Seal B	BS-7029	1
2-3	ZW384131	Screw, round head 3x5		6
2-4	ZW494741	Washer (Nylon)D7.9x12x1t		1
2-5	MZ532383	Retaining Base A	TW-7011	1
2-6	ZW537941	Screw, pan head 4x65, w/washer	7-1-54	4
2-7	MZ532451	Motor Retaining Plate	TW-7018	1
2-8	ZW424056	Screw, pan head 4x10		7
2-9	ZW532462	Motor Prop	TW-7019	3
2-10	MR532440	Pulley	TW-7017	1
2-11	ZW459033	Set Screw, hexagon socket 5x5(cup)		2
2-12	BZ556694	Detector Gear Block Comp.	TW	1
2-13	ZW537974	Screw, countersunk head 2x12		3
2-14x	ZW334653	'E' Ring 7M	6-1-9	1
2-15	SZ450720	Motor Fan	BS-7015	1
2-16	ZW391476	Set Screw, hexagon socket 4x4(cup)		2

When ordering parts, please describe Parts Number, Serial Number, and Model Number in detail.

FIG. 3 ILLUSTRATION OF REEL MOTOR & REEL TABLE BLOCK

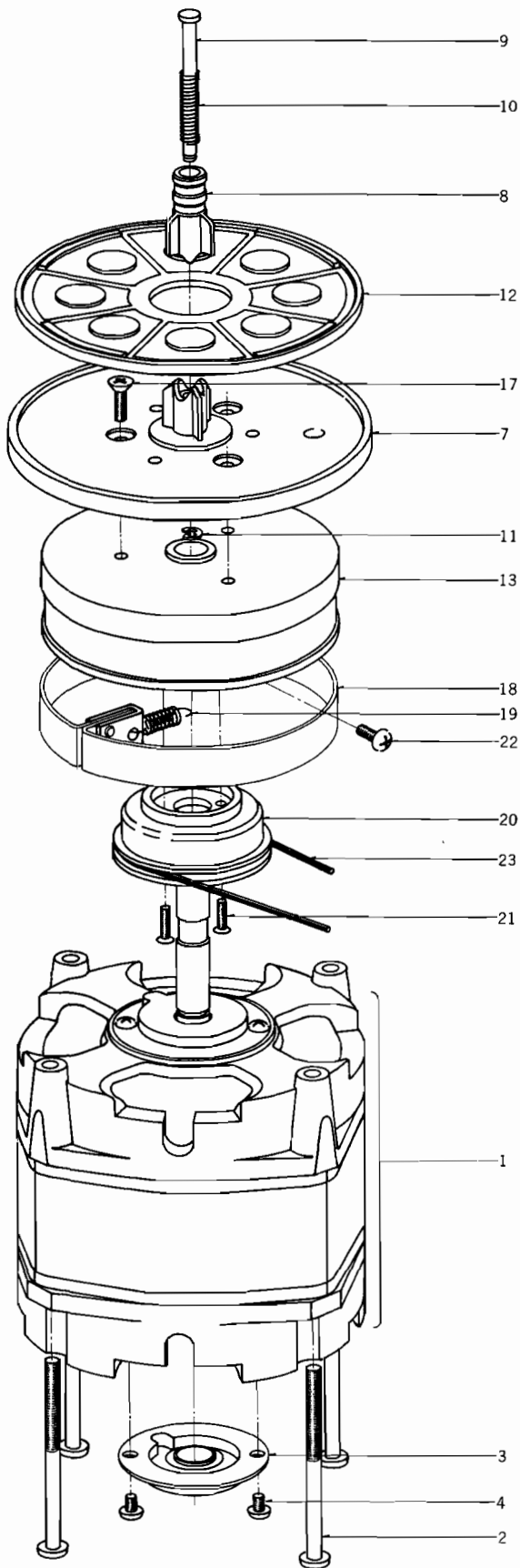

REEL MOTOR & REEL TABLE BLOCK

Ref. No.	Parts No.	Description	Schematic No.	Q'ty
REEL MOTOR BLOCK				
3-1	BM552137	Reel Motor (LM1-24TW) Block		1
3-2	ZW537930	Screw, pan head 4x55, w/washer	TW 7-1-54	4
3-3	ZW459167	48 Seal B	BS-7029	2
3-4	ZW384131	Screw, round head 3x5		4
REEL TABLE (L) (R) BLOCK				
3-5x	BR552328	Reel Table (R) Block Comp. (Take-up)	TW	1
3-6x	BR552317	Reel Table (L) Block Comp. (Supply)	TW	1
3-7	MT534666	Reel Table	TW-2031	1
3-8	MT534677	Reel Clamper	TW-2032	1
3-9	MS342000	Reel Shaft	3R-108	1
3-10	ZG540617	Clamper Spring	TW-2096	1
3-11	ZW270088	'E' Ring 1.9M	6-1-9	1
3-12	MT534688	Reel Table Rubber	TW-2033	1
3-13	MT473433	Brake Drum (R) (Take-up)	KH-2031	1
3-14x	MT473444	Brake Drum (L) (Supply)	KH-2031	1
3-15x	ZW273778	Earth Lug M3		1
3-16x	ZW425981	Screw, binding head 3x3		1
3-17	ZW425103	Screw, countersunk head 3x10		3
3-18	MT436860	Brake Cloth Comp.	MR-269	1
3-19	ZG317496	Felt Tension Spring	MR-260	1
3-20	MR534690	Counter Pulley	TW-2034	1
3-21	ZW433315	Screw, countersunk head 2.3x8		2
3-22	ZW435273	Screw, binding head 4x10		4
3-23	MB533057	Counter Belt A (D119.1x1.4)	TW-1018	1
3-24x	MB533068	Counter Belt B (D91.8x1.2)	TW-1019	1

When ordering parts, please describe Parts Number, Serial Number, and Model Number in detail.

FIG. 4 ILLUSTRATION OF FLYWHEEL & PINCH ROLLER ARM BLOCK

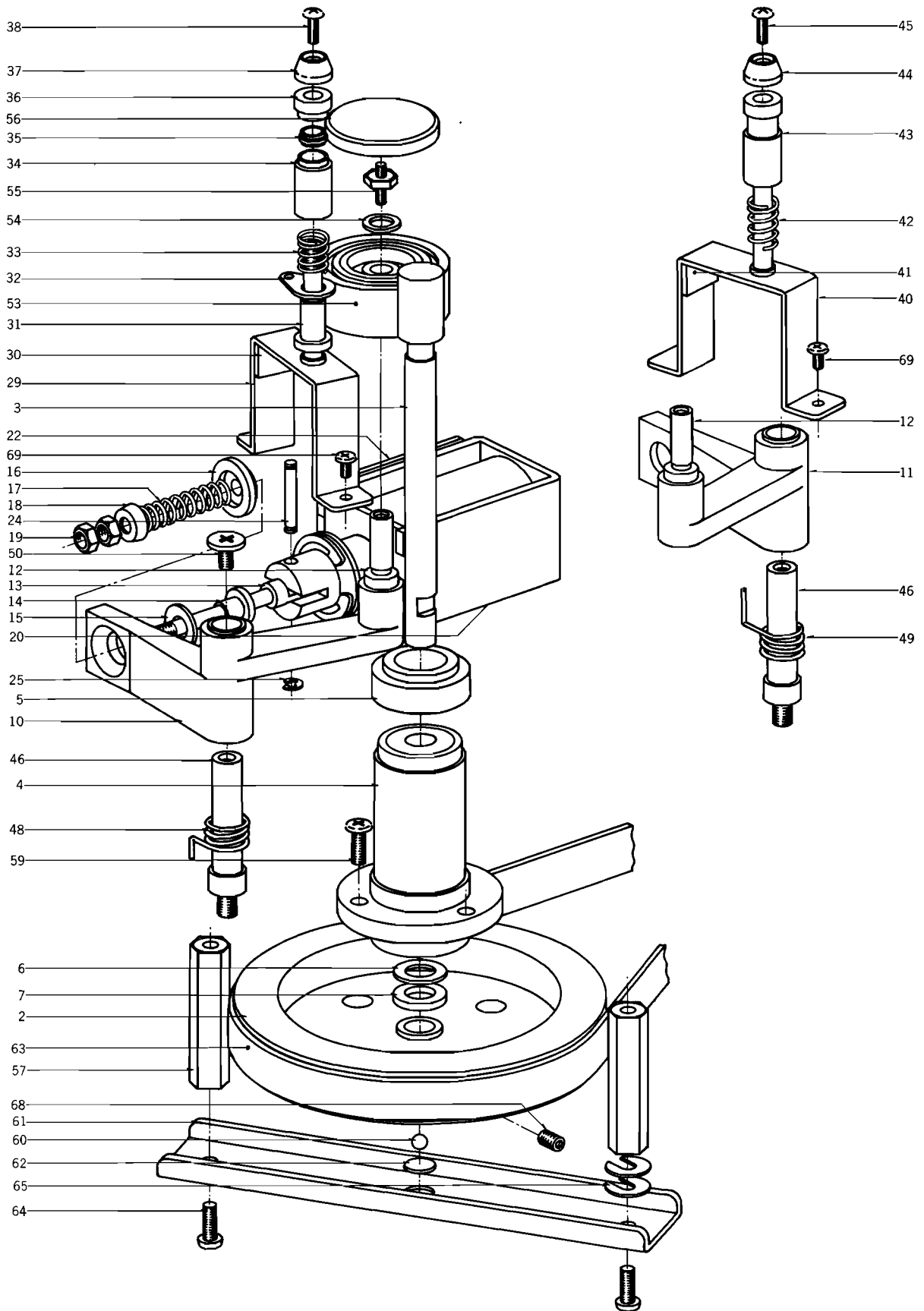

FLYWHEEL & PINCH ROLLER ARM BLOCK

Ref. No.	Parts No.	Description	Schematic No.	Q'ty	Ref. No.	Parts No.	Description	Schematic No.	Q'ty
FLYWHEEL BLOCK					MECH. ASSEMBLY BLOCK				
4-1x	BF552330	Flywheel Block Comp.	TW	1	4-46	MS532956	Pinch Arm Shaft	TW-1006	2
4-2	MI534734	Flywheel	TW-2040	1	4-47x	ZW413278	Nut M5		2
4-3	MS534723	Capstan Shaft	TW-2038	1	4-48	ZG533711	Pinch Arm Spring B (L)	TW-1037	1
4-4	MZ534701	Main Case, w/metal	TW-2035	1	4-49	ZG533700	Pinch Arm Spring A (R)	TW-1036	1
4-5	SK534745	Main Case Cap	TW-2042	1	4-50	ZW243516	Screw, Pinch Roller	XR-140	2
4-6	ZW260245	Washer (Nylon)D7.9x13x1t		1	4-51x	ZW560215	Washer (Teflon)D6.1x10x0.5t		2
4-7	VM360090	Capstan Felt	PX-217	1	4-52x	ZW560226	Washer (PBP)D6.1x10x0.2t		2
PINCH ROLLER ARM (L) (R) BLOCK									
4-8x	BL552150	Pinch Roller Arm (L) Block			4-53	MP533744	Pinch Roller TW D=36	TW-1040	2
		Comp.	TW	1	4-54	ZW430402	Washer (Nylon)D6.2x10x0.5t		2
4-9x	BL552161	Pinch Roller Arm (R) Block			4-55	ZW533766	Screw, TW Pinch Roller	TW-1042	2
		Comp.	TW	1	4-56	SK534374	Pinch Roller Cap	TW-6019	2
4-10	ML533856	Pinch Roller Arm B (L)	TW-2003	1	4-57	MH532967	Supporting Plate Prop	TW-1007	4
4-11	ML533845	Pinch Roller Arm A (R)	TW-2001	1	4-58x	ZW416687	Screw, binding head 4x8		4
4-12	MS533867	Pinch Roller Shaft	TW-2005	2	4-59	ZW413201	Screw, pan head 4x8		6
4-13	ML533878	Pull Bar	TW-2006	2	4-60	MV269965	Steel Ball D=4		2
4-14	MZ533880	Collar	TW-2007	2	4-61	MZ453767	Thrust Bracket	BS-1022	2
4-15	ZW533891	Rubber Washer	TW-2008	2	4-62	ZW462205	Washer without Hole D7.9x1t		2
4-16	ZW533902	Spring Stopper	TW-2009	2	4-63	MB533070	Flat Belt D241.5x1.6t	TW-1020	1
4-17	ZG243257	Pinch Roller Compression			4-64	ZW416687	Screw, binding head 4x8		4
		Spring	3A-346	2	4-65	ZW330412	Adjust. Washer (U)D4x13x0.13t		2
4-18	MZ802980	Spring Holder	RD-276	2	4-66x	ZW330423	Adjust. Washer (U)D4x13x0.25t		2
4-19	ZW416698	Nut M4		2	4-67x	ZW330445	Adjust. Washer (U)D4x13x0.8t		2
4-20	EP538457	Plunger Solenoid 1660PHT-2	44-1-56	2	4-68	ZW459033	Set Screw, hexagon socket		4
4-21x	ED224550	Silicon Diode 10D4 (R)	45-2-16	3			5x5(cup)		4
4-22	ML533924	Plunger Base B	TW-2011	2	4-69	ZW323728	Screw, binding head 3x5		4
4-23x	ZW413155	Screw, binding head 3x6		4					
4-24	ZW533913	Connection Pin	TW-2010	2					
4-25	ZW270088	'E' Ring 1.9M	6-1-9	4					
4-26x	EJ255093	Lug Plate VB1L1 (R)	33-4-1	1					
4-27x	ZW323728	Screw, binding head 3x5		1					
SENSING GUIDE BLOCK									
4-28x	BZ552396	Sensing Guide Block Comp.	TW	1					
4-29	MZ535116	Guide Table, w/prop	TW-2079	1					
4-30	MZ535228	Cushion Rubber	TW-2089	1					
4-31	MZ535138	Insulator Bush C	TW-2081	1					
4-32	MZ535140	Conductor Terminal	TW-2082	1					
4-33	ZG535151	Guide Spring A	TW-2083	1					
4-34	MS535195	Sensing Guide D	TW-2086	1					
4-35	MZ535206	Insulator Bush D	TW-2087	1					
4-36	MS535184	Sensing Guide C	TW-2085	1					
4-37	MZ535217	Guide Adjust. Nut	TW-2088	1					
4-38	ZW203084	Screw, oval countersunk head							
		3x8		1					
TAPE GUIDE BLOCK									
4-39x	BZ552385	Tape Guide Block Comp.	TW	1					
4-40	MZ535116	Guide Table, w/prop	TW-2079	1					
4-41	MZ535228	Cushion Rubber	TW-2089	1					
4-42	ZG535162	Guide Spring B	TW-2083	1					
4-43	MS535173	Tape Guide D	TW-2084	1					
4-44	MZ535217	Guide Adjust. Nut	TW-2088	1					
4-45	ZW203084	Screw, oval countersunk head							
		3x8		1					

When ordering parts, please describe Parts Number, Serial Number, and Model Number in detail.

FIG. 5 ILLUSTRATION OF TENSION ARM & DAMPER BLOCK

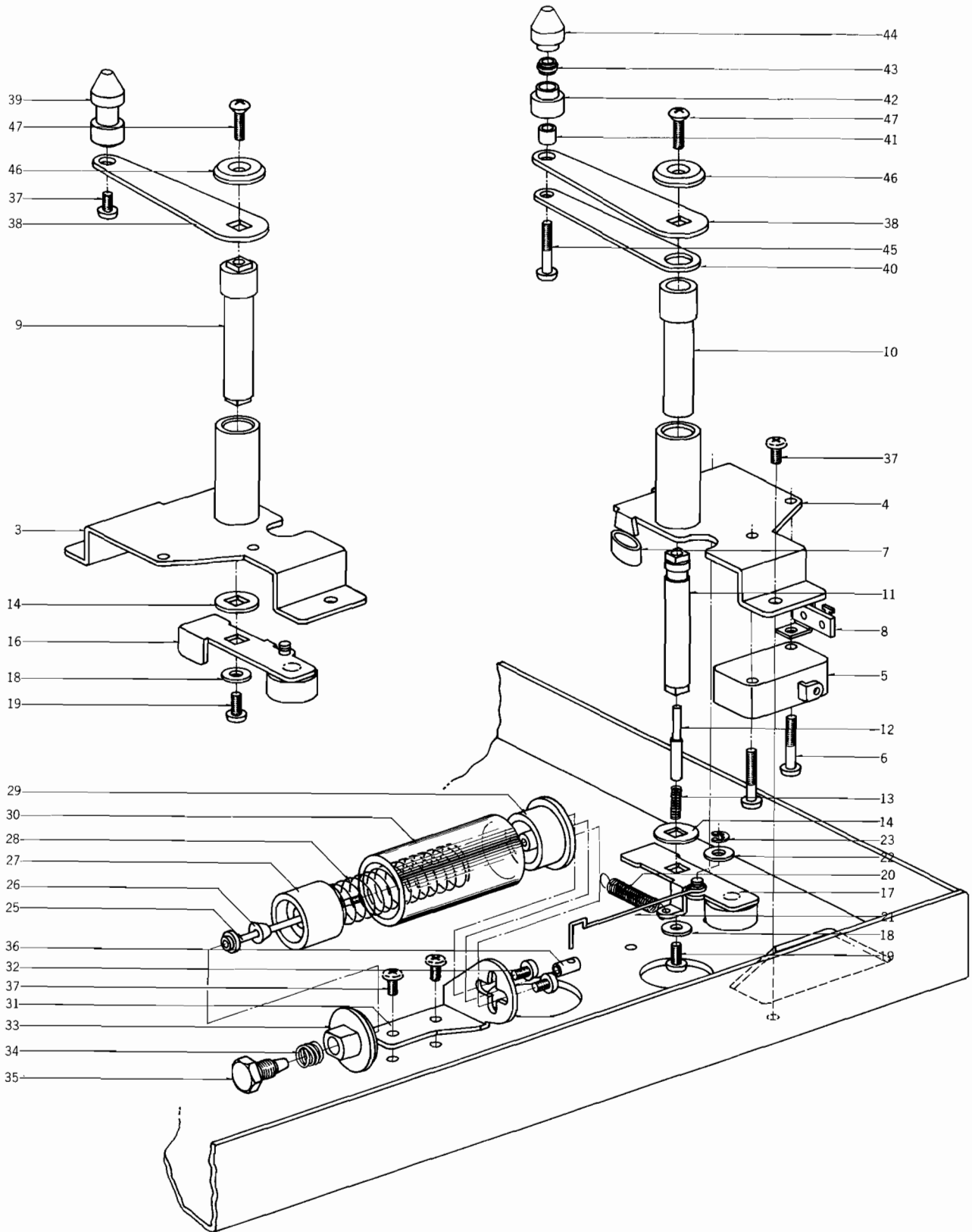

TENSION ARM & DAMPER BLOCK

Ref. No.	Parts No.	Description	Schematic No.	Q'ty
TENSION ARM (L) (R) BLOCK				
5-1x	BL552363	Tension Arm (L) Block Comp.	TW	1
5-2x	BL552374	Tension Arm (R) Block Comp.	TW	1
5-3	ML534914	Tension Arm Table B, w/metal (L)	TW-2059	1
5-4	ML534903	Tension Arm Table A, w/metal (R)	TW-2059	1
5-5	ES250064	Micro Switch V-1A44 U/L	25-1-7	2
5-6	ZW417148	Screw, binding head 3x15		4
5-7	MZ810191	RD Cushion Rubber	RD-278	2
5-8	EJ368853	Lug Plate VB1L	33-4-8	2
5-9	MS534936	Tension Arm Shaft A (L)	TW-2061	1
5-10	MS534947	Tension Arm Shaft B (R)	TW-2062	1
5-11	MZ534958	Insulator Liner (R)	TW-2063	1
5-12	ZW535015	Conductor Pin (R)	TW-2068	1
5-13	ZG535026	Conductor Spring (R)	TW-2069	1
5-14	ZW534982	Tension Arm Washer	TW-2065	2
5-15x	ZW554005	Set Screw 2x2(cup)		2
5-16	ML534971	Tension Switch Lever B (L), w/pin	TW-2064	1
5-17	ML534960	Tension Switch Lever A (R), w/pin	TW-2064	1
5-18	ZW425002	Washer (SPC)D3.1x8x0.5t		2
5-19	ZW413155	Screw, binding head 3x6		2
5-20	ZG535105	Tension Arm Spring	TW-2078	2
5-21	MZ533676	Damper Wire	TW-1033	2
5-22	ZW550642	Washer (SPC)D3.1x7.9x0.5t		2
5-23	ZW270088	'E' Ring 1.9M	6-1-9	2

DAMPER BLOCK

5-24x	BZ552341	Damper Block Comp.	TW	1
5-25	MS534778	Damper Shaft, w/seat	TW-2045	1
5-26	MZ534791	Damper Valve	TW-2047	1
5-27	MZ534767	Piston	TW-2044	1
5-28	ZG534824	Damper Spring	TW-2050	1
5-29	MZ534802	Damper Metal	TW-2048	1
5-30	MZ534756	Cylinder	TW-2043	1
5-31	MZ534868	Damper Base	TW-2054	1
5-32	ZW384131	Screw, round head 3x5		2
5-33	MZ534813	Damper Cap	TW-2049	1
5-34	ZG534846	Needle Adjust. Spring	TW-2052	1
5-35	MZ534835	Adjust. Bolt	TW-2051	1
5-36	MZ534857	Damper Joint	TW-2053	1

MECH. ASSEMBLY BLOCK

5-37	ZW323728	Screw, binding head 3x5		9
5-38	ML535037	Tension Arm	TW-2070	2
5-39	MS533147	Tape Guide C	TW-2072	1
5-40	EA535048	Tension Arm P.C. Board	TW-2071	1
5-41	MZ535083	Insulator Bush B	TW-2076	1
5-42	MS535061	Sensing Guide B	TW-2074	1
5-43	MZ535072	Insulator Bush A	TW-2075	1
5-44	MS535050	Sensing Guide A	TW-2073	1
5-45	ZW417148	Screw, binding head 3x15		1
5-46	SZ535094	Decorative Washer	TW-2077	2
5-47	ZW408690	Screw, oval countersunk head 3x10		2

FIG. 6 ILLUSTRATION OF OPERATION BLOCK

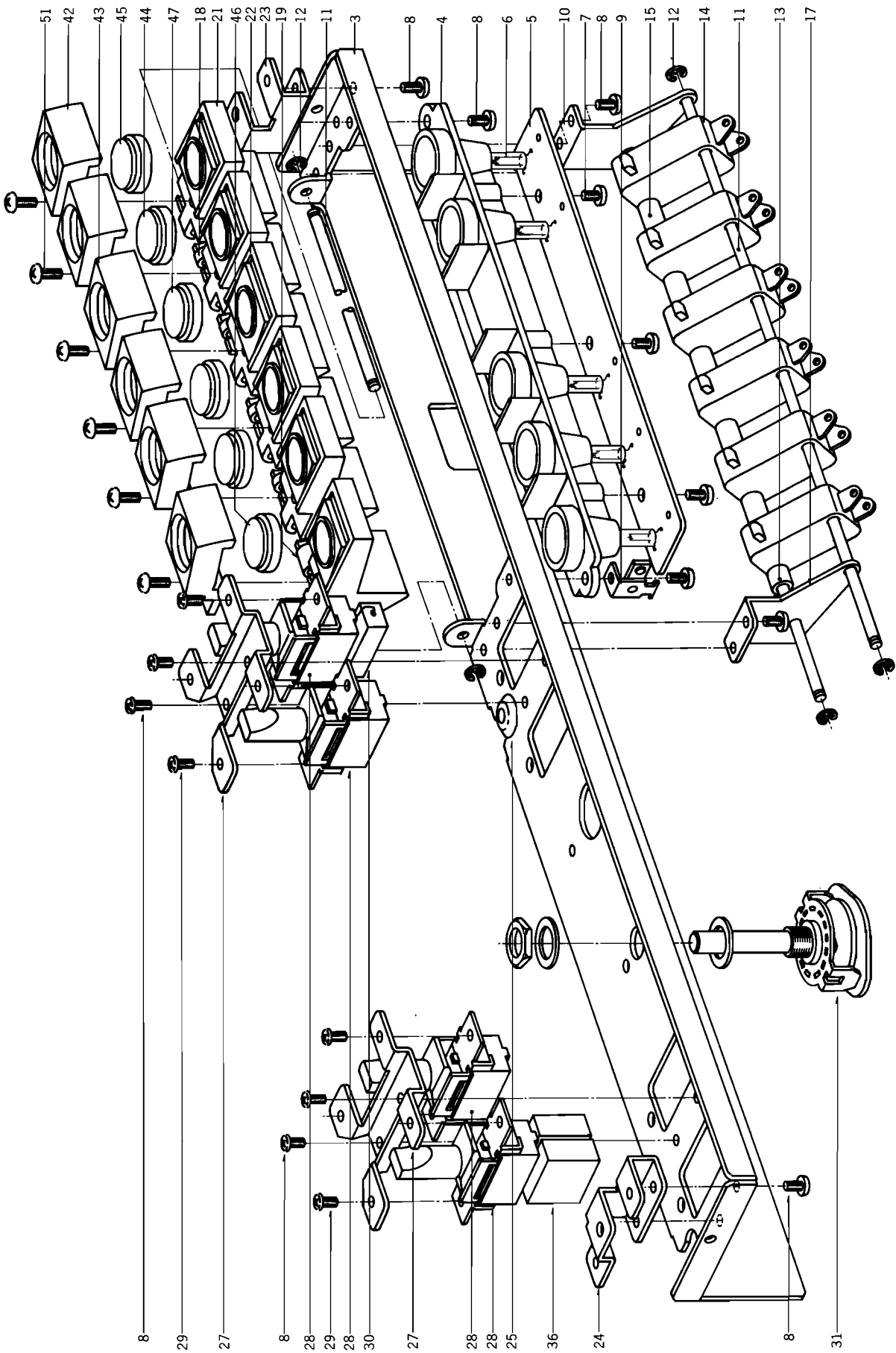

OPERATION BLOCK

Ref. No.	Parts No.	Description	Schematic No.	Q'ty
6-1x	BZ552295	Operation Block Comp.	TW-1	1
6-2x	BZ552306	Operation Block Comp. (PRO)	TW-2	1
6-3	MZ534047	Control Chassis	TW-2020	1
6-4	MZ534611	Lamp Holder	TW-2027	1
6-5	EA534622	Lamp P.C. Board	TW-2028	1
6-6	EL390576	Pilot Lamp RM6-24V-50MA (Lead type)	28-2-6	5
6-7	ZW447772	Tapping Screw #2 3x6(BR)		3
6-8	ZW323728	Screw, binding head 3x5		14
6-9	EJ368853	Lug Plate VB1L	33-4-8	1
6-10	MZ534587	Operation Switch Base A	TW-2025	1
6-11	MS534600	Operation Shaft	TW-2026	3
6-12	ZW270088	'E' Ring 1.9M	6-1-9	6
6-13	MZ532574	Switch Collar B L=7.9	TW-2024	2
6-14	ES250075	Micro Switch V-1A10 U/L	25-1-8	6
6-15	MZ532585	Switch Collar C L=16	TW-2024	5
6-16x	MZ540011	Switch Collar E L=42.5 (PRO)	TW-2202	1
6-17	MZ534598	Operation Switch Base B	TW-2025	1
6-18	MZ532563	Switch Collar A L=2.9	TW-2024	4
6-19	MZ532574	Switch Collar B L=7.9	TW-2024	1
6-20x	MZ540000	Switch Collar D L=32.8 (PRO)	TW-2202	1
6-21	MZ534058	Operation Button Base A	TW-2021	5
6-22	MZ534060	Operation Button Base B	TW-2021	1
6-23	MZ534644	Panel Support A	TW-2030	1
6-24	MZ534655	Panel Support B	TW-2030	1
6-25	EZ428117	Rubber Bushing	AA-801	1
6-26x	EL443520	Pilot Lamp 8V 80MA(60M/Mx2) (Pause)	28-2-22	1
6-27	ML534633	Lever Switch Base	TW-2029	2
6-28	ES537873	Lever Switch JLO5, w/knob	25-4-14	4
6-29	ZW371856	ISO Screw, binding head 3x5		8
6-30	ER560744	Cement/R. 3W 39(K) (Wire-wound Type)	35-16-2	1
6-31	ES538132	Rotary Switch SR-25N1-3-3 35R	25-6-49	1
6-32x	ES551935	Rotary Switch SR-25N1-3-2 35R (PRO)	25-6-62	1
6-33x	ZW273778	Earth Lug M3		1
6-34x	ZW273756	Nut M3		1
6-35x	ER429996	Carbon/R. RD1/4 470k(J) (Stop. type)	35-10-1	2
6-36	ER376424	Spark Quencher U/L 0.1μ+120 500WV	41-1-36	2
6-37x	ML533610	Lamp Table (Rec.) (PRO)	TW-2201	1
6-38x	EA549472	Lamp P.C. Board B (PRO)	TW-2204	1
6-39x	EL390576	Pilot Lamp RM6-24V-50MA (Rec.) (PRO)	28-2-6	1
6-40x	ZW417227	Screw, binding head 2.3x5		2
6-41x	ZW447772	Tapping Screw #2 3x6(BR)		1
6-42	SB534071	Operation Button A	TW-2022	5
6-43	SB534082	Operation Button B (Stop)	TW-2022	1
6-44	SE534093	Operate Lamp Escutcheon A (green)	TW-2023	2
6-45	SE532517	Operate Lamp Escutcheon B (orange)	TW-2023	2
6-46	SE532528	Operate Lamp Escutcheon C (red)	TW-2023	1
6-47	SE532552	Operate Lamp Escutcheon D (black)	TW-2023	1
6-48x	SB540022	Operation Button C (PRO)	TW-2203	3
6-49x	SB540033	Operation Button D (Stop) (PRO)	TW-2203	1
6-50x	SB540044	Operation Button E (Rec.) (PRO)	TW-2203	1
6-51	ZW447840	Tapping Screw #2 3x8(BR)		6

When ordering parts, please describe Parts Number, Serial Number, and Model Number in detail.

FIG. 7 ILLUSTRATION OF MECHANISM ASSEMBLY BLOCK

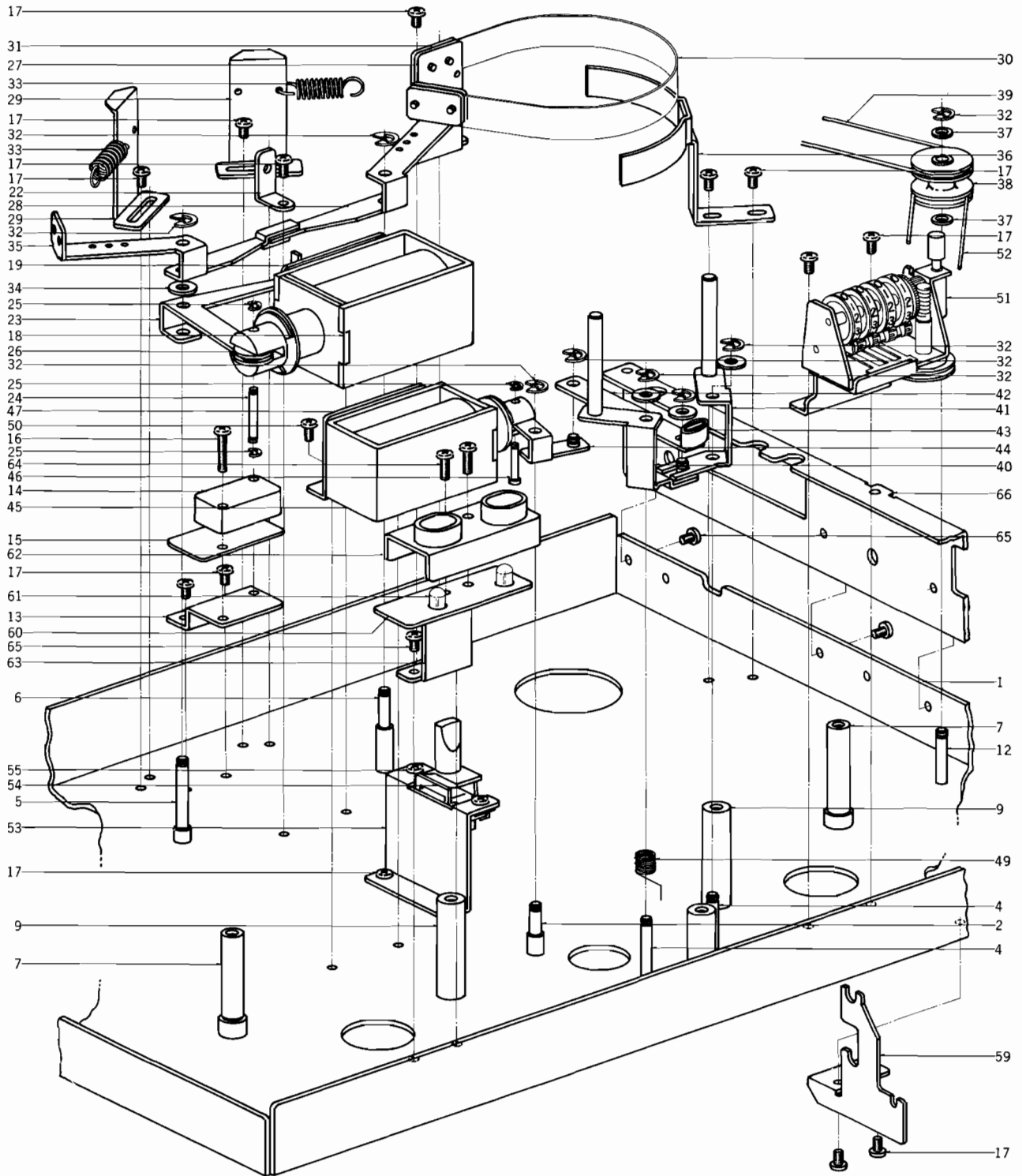

MECHANISM ASSEMBLY BLOCK

Ref. No.	Parts No.	Description	Schematic No.	Q'ty
7-1	MZ532271	Mech. Frame	TW-1001	1
7-2	MH532912	Shifter Lever Prop A	TW-1002	1
7-3x	ZW273756	Nut M3		5
7-4	MH532923	Shifter Lever Prop B	TW-1003	2
7-5	MH532934	Brake Lever Prop A	TW-1004	1
7-6	MH532945	Brake Lever Prop B	TW-1005	1
7-7	MS532956	Pinch Arm Shaft	TW-1006	2
7-8x	ZW413278	Nut M5		2
7-9	MH532978	Head Base Prop	TW-1008	3
7-10x	ZW416687	Screw, binding head 4x8		7
7-11x	ZW273914	Spring Washer M4		3
7-12	MS532980	Pulley Shaft	TW-1009	1
7-13	ML533035	QT Switch Base	TW-1015	1
7-14	ES250064	Micro Switch V-1A44 U/L	25-1-7	1
7-15	MZ250413	Micro Insulator C	RC-127	1
7-16	ZW413785	Screw, binding head 3x12		2
7-17	ZW323728	Screw, binding head 3x5		33
7-18	EP537906	Plunger Solenoid 1660THT 2	44-1-54	1
7-19	ML533924	Plunger Base B	TW-2011	1
7-20x	ZW413155	Screw, binding head 3x6		2
7-21x	ED224550	Silicon Diode 10D4	45-2-16	1
7-22	ML237418	Hum Backing Coil Metal Fitting (L type)	M8-103	1
7-23	ML533654	Brake Lever C	TW-1031	1
7-24	ZW533913	Connecting Pin	TW-2010	1
7-25	ZW270088	'E' Ring 1.9M	6-1-9	3
7-26	ZW561486	Washer (BSP)D4.1x13x0.8t		2
7-27	ML533665	Brake Band Support	TW-1032	2
7-28	ML533632	Brake Lever A	TW-1029	1
7-29	ML543025	Brake Adjust. Plate	TW-1061	2
7-30	MB314987	Brake Band	MR-213	2
7-31	MZ314998	Brake Band Retaining Plate	MR-212	4
7-32	ZW290283	'U' Ring 2.85M	6-1-1	6
7-33	ZG540090	Brake Lever Spring	TW-1058	2
7-34	ZW382162	Washer (SPC)D4.1x11x0.25t		1
7-35	ML533643	Brake Lever B	TW-1030	1
7-36	ML533687	Brake Band Guide Table, w/guide	TW-1034	2
7-37	ZW259773	Washer (Nylon)D4.1x7x0.5t		2
7-38	MR533002	Middle Pulley (Counter), w/metal	TW-1012	1
7-39	MB533057	Counter Belt A D119.1x1.4	TW-1018	1
7-40	ML533092	Shifter Lever B, w/pin	TW-1022	1
7-41	ML533103	Shifter Lever C, w/pin	TW-1023	1
7-42	ML533114	Shifter Lever D	TW-1024	1
7-43	MZ810191	RD Cushion Rubber	RD-278	1
7-44	ML533081	Shifter Lever A, w/pin	TW-1021	1
7-45	EP537895	Plunger Solenoid 1254THT	44-1-53	1
7-46	ZW257477	Connecting Pin	RD-211	1
7-47	ML533621	Plunger Base A	TW-1028	1
7-48x	ED224550	Silicon Diode 10D4	45-2-16	1
7-49	ZG533733	Shifter Spring B	TW-1039	1
7-50	ZW413223	Screw, binding head 3x5, w/washer		2
7-51	MC399521	Counter M-470D (w/base)	9-1-14	1
7-52	MB533068	Counter Belt B (D91.8x1.2)	TW-1019	1
7-53	ML533046	RS Switch Table	TW-1016	1
7-54	ES537873	Lever Switch JLO5 (w/knob)	25-4-14	1
7-55	ZW371856	ISO Screw, binding head 3x5		2
7-56x	ZW330412	Adjust. Washer (U)D4x13x0.13t		1
7-57x	ZW330423	Adjust. Washer (U)D4x13x0.25t		1
7-58x	ZW330445	Adjust. Washer (U)D4x13x0.8t		1
7-59	MZ533698	Supporting Base	TW-1035	1
7-60	BA552352	Direction P.C. Board Comp. (TW-2057)	TW-1	1
7-61	EL390576	Pilot Lamp RM6-24V-50MA	28-2-6	2
7-62	EZ534892	Direction House	TW-2058	1
7-63	EZ534870	Direction Table	TW-2055	1
7-64	ZW417194	Screw, binding head 3x10		2
7-65	ZW323728	Screw, binding head 3x5		10
7-66	ML533777	Panel Support C (Right)	TW-1043	1
7-67x	ML533788	Panel Support D (Left)	TW-1043	1

When ordering parts, please describe Parts Number, Serial Number, and Model Number in detail.

FIG. 8 ILLUSTRATION OF POWER SUPPLY BLOCK

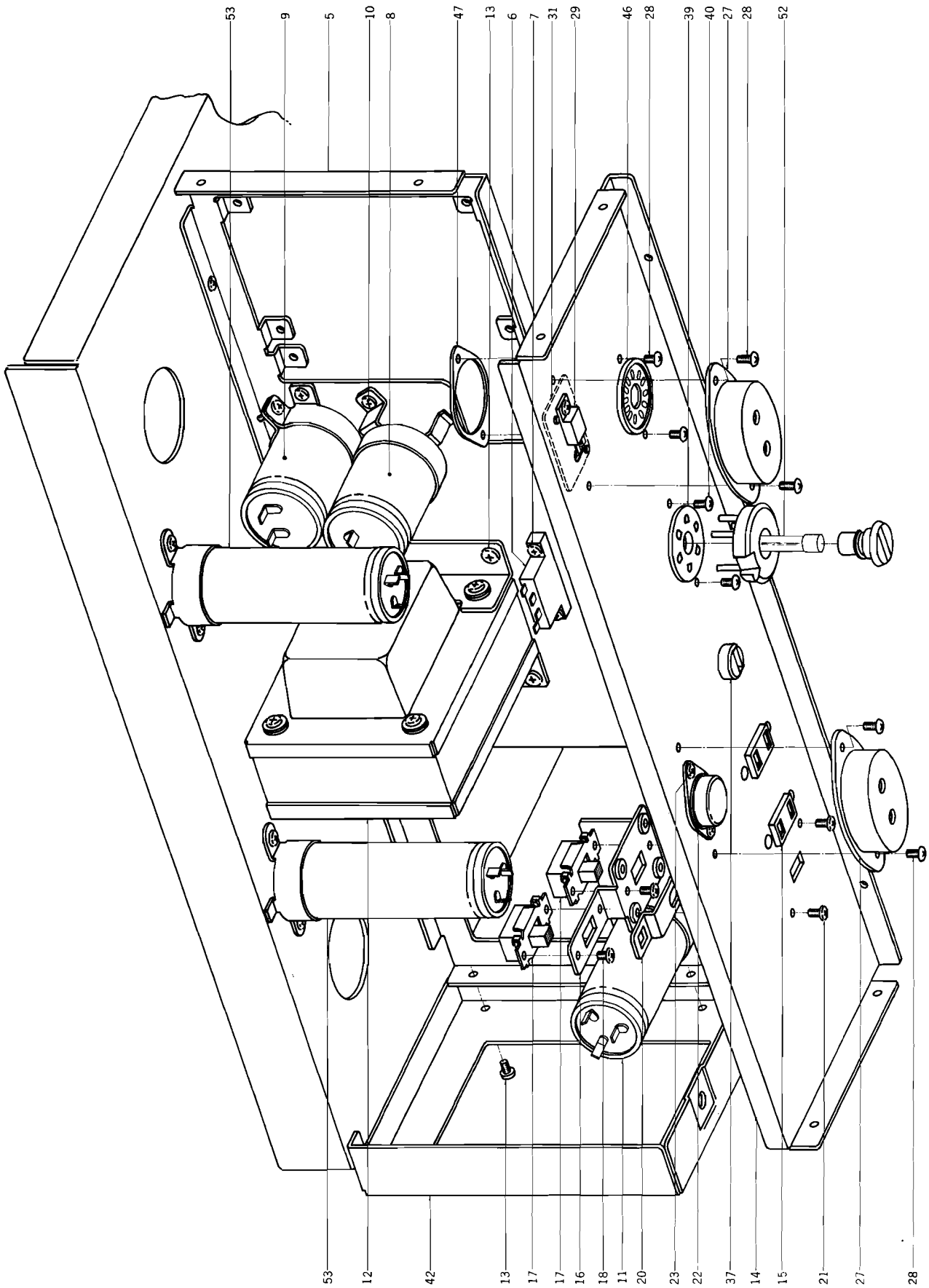

POWER SUPPLY BLOCK

Ref. No.	Parts No.	Description	Schematic No.	Qty
8-1x	BP552227	Power Supply Block Comp.	TW-1	1
8-2x	BP552240	Power Supply Block Comp. (3 core)	TW-1	1
8-3x	BP552238	Power Supply Block Comp. (PRO)	TW-2	1
8-4x	BP552251	Power Supply Block Comp. (PRO 3 core)	TW-2	1
8-5	MZ533935	Power Chassis	TW-2012	1
8-6	ED224572	Silicon Diode 5B2	45-2-20	1
8-7	ZW413741	Screw, binding head 3x8		6
8-8	ED557190	Elect./C. 470 μ F 16WV(Lug type)	24-10-88	1
8-9	EC368695	Elect./C. 2200 μ F 50WV (Lug type)	24-10-45	1
8-10	ZW447772	Tapping Screw #2 3x6(BR)		13
8-11	EC538018	MP/C. 4+1.5 μ F 150WV	24-9-71	1
8-12	BT538020	Power Trans. TWT-2	38-4-223	1
8-13	ZW416687	Screw, binding head 4x8		8
8-14	MZ533968	Rear Plate A	TW-2014	1
8-15	EJ378944	U/L AC Socket S-1 9122	31-1-47	2
8-16	EZ397304	Cycle Change Switch Plate A	KD-2043	1
8-17	ES479485	Slide Switch S-1	25-3-66	2
8-18	ZW371856	ISO Screw, binding head 3x5		2
8-19x	ZW327835	ISO Screw, countersunk head 3x5		2
8-20	EZ397124	Cycle Change Switch Plate B	KD-1055	1
8-21	ZW201150	Screw, truss head 3x6(black)		2
8-22	ET538007	Transistor 2SC792	45-1-139	1
8-23	ZW417194	Screw, binding head 3x10		2
8-24x	ZW273778	Earth Lug M3		2
8-25x	ZW273745	Spring Washer M3		1
8-26x	ZW273756	Nut M3		3
8-27	EZ534025	Transistor Cover	TW-2017	2
8-28	ZW201150	Screw, truss head 3x6(black)		4
8-29	ET393557	Transistor 2SD234(R)(O)	45-1-81	1
8-30x	EZ409836	Insulator Plate AC-221	45-1-90	1
8-31	EA534036	Transistor P.C. Board	TW-2019	1
8-32x	ZW413741	Screw, binding head 3x8		1
8-33x	ZW323728	Screw, binding head 3x5		10
8-34x	EW540112	AC Cord 2.5M(CUL)	26-3-19	1
8-35x	EZ315448	Australia Cord (3 core)	26-3-11	1
8-36x	EW524845	AC Cord 2.5M(J)	26-3-31	1
8-37	EZ382263	Strain Relief SR-4K-4	2-7-12	1
8-38x	EZ246936	Strain Relief SR-6W-1(3 core)	2-7-8	1
8-39	EJ233370	Power Plug Socket S-18010	40-2-3	1
8-40	ZW372025	ISO Screw, truss head 3x6		2
8-41x	MZ533946	Mech. Side Plate A (Left)	TW-2013	1
8-42	MZ533957	Mech. Side Plate B (Right)	TW-2013	1
8-43x	EZ534003	Connector Angle	TW-2015	1
8-44x	EJ347670	22P Multi-jack-3 3250-022-001S	31-4-13	2
8-45x	EJ364915	10P Multi-jack PB01-10S-24E2G	31-4-15	1
8-46	EJ222748	Sub Magnale Socket #311SG	31-1-39	1
8-47	MZ302400	Remo. Con. Socket Mt. Plate	RX-515	1
8-48x	EJ293073	12P Mate-N-Lock Plug Housing 1-480275-0	52-1-1	1
8-49x	EJ373634	Socket Contact 61115-1	52-1-1	17
8-50x	EJ368796	9P Mate-N-Lock Plug Housing 1-480274-0	52-1-2	1
8-51x	EJ205986	Cramp Terminal 2-SD	32-1-8	2
8-52	EF424811	Fuse ST-2 2.5A	39-1-26	1
8-53	EC537884	MP/C. 3.5+1 μ F 260WV (Lug type)	24-9-76	2

When ordering parts, please describe Parts Number, Serial Number, and Model Number in detail.

FIG. 9 PHOTO OF SERVO P.C. BOARD (TW-1049)

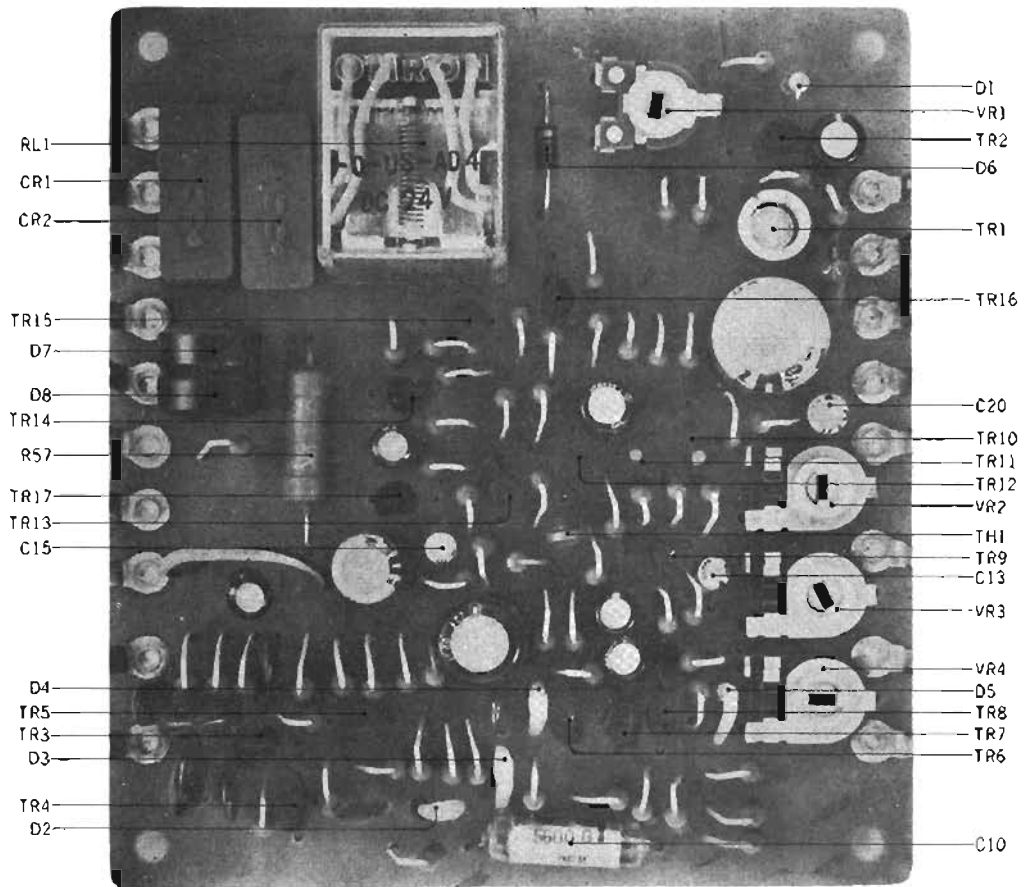

SERVO P.C. BOARD (TW-1049) BLOCK

Symbol No.	Parts No.	Description	Q'ty	Symbol No.	Parts No.	Description	Q'ty
9-1x	BA552407	Servo P.C. Board Comp.(TW-1049)	1	9-R21	ER336442	Carbon RD1/4 10k(J)	
9-TR1	ET334383	Transistor 2SC971	1	9-R22	ER306887	Carbon RD1/4 15k(J)	
9-TR2, 3	ET379462	Transistor 2SC711(D)(E)	2	9-R23	ER346601	Carbon RD1/4 47k(J)	
9-TR4	ET538154	Transistor 2SA564(Q)(R)	1	9-R24	ER213030	Carbon RD1/4 5.6k(J)	
9-TR5 to 8	ET379462	Transistor 2SC711(D)(E)	4	9-R25	ER211320	Carbon RD1/4 1.5k(J)	
9-TR9	ET538154	Transistor 2SA564(Q)(R)	1	9-R26	ER213030	Carbon RD1/4 5.6k(J)	
9-TR10, 11	ET538143	Transistor 2SC711 (E2-Special)	2	9-R27	ER211465	Carbon RD1/4 1k(J)	
9-TR12	ET379462	Transistor 2SC711(D)(E)	1	9-R28	ER352045	Carbon RD1/4 3.9k(J)	
9-TR13	ET538154	Transistor 2SA564(Q)(R)	1	9-R29	ER212477	Carbon RD1/4 3.3k(J)	
9-TR14	ET399881	Transistor 2SC711(F)	1	9-R30	ER211320	Carbon RD1/4 1.5k(J)	
9-TR15	ET379462	Transistor 2SC711(D)(E)	1	9-R31	ER346544	Carbon RD1/4 10k(J)	
9-TR16, 17	ET398711	Transistor 2SC945(Q)(R)	2	9-R32	ER357456	Carbon RD1/4 2.2k(J)	
9-D1	ED350471	Zener Diode RD-7A(N)	1	9-R33	ER212883	Carbon RD1/4 4.7k(J)	
9-D2, 3, 4	ED224526	Silicon Diode 10D1	3	9-R34	ER211757	Carbon RD1/4 100k(J)	
9-D5	ED538042	Zener Diode RD-7A(L)	1	9-R35	ER336442	Carbon RD1/4 10k(J)	
9-D6	ED224526	Silicon Diode 10D1	1	9-R36	ER336442	Carbon RD1/4 10k(J)	
9-D7	ED538165	Silicon Diode 10DC-2(red)	1	9-R37	ER304402	Carbon RD1/4 470(J)	
9-D8	ED538176	Silicon Diode 10DC-2(black)	1	9-R38, 39	ER336442	Carbon RD1/4 10k(J)	
9-RL1	EP344136	Relay MY 4-0-US-AD4-24V	1	9-R40	ER306843	Carbon RD1/4 1.2k(J)	
9-CR1, 2	ER376435	Spark Quencher U/L 0.1μ+120 250WV	2	9-R41	ER336442	Carbon RD1/4 10k(J)	
9-VR1	EV484863	Semi-fixed Volume V10K8-4-2 1 kΩ	1	9-R42	ER430007	Carbon RD1/4 1.5M(J)	
9-VR2	EV538187	Semi-fixed Volume V10K4H-4-2 5 kΩ	1	9-R43	ER213030	Carbon RD1/4 5.6k(J)	
9-VR3	EV538198	Semi-fixed Volume V10K4H-4-2 10 kΩ	1	9-R44	ER357456	Carbon RD1/4 2.2k(J)	
9-VR4	EV538200	Semi-fixed Volume V10K4H-4-2 30 kΩ	1	9-R45	ER212681	Carbon RD1/4 330(J)	
9-TH1	ED557201	Thermister 31D26	1	9-R46	ER357456	Carbon RD1/4 2.2k(J)	
Capacitor, Vertical Type				9-R47	ER211465	Carbon RD1/4 1k(J)	
9-C1	EC220994	Elect. 10μF 25WV	1	9-R48	ER357456	Carbon RD1/4 2.2k(J)	
9-C2	EC250604	Mylar 0.001μF(K) 50WV	1	9-R49	ER346601	Carbon RD1/4 47k(J)	
9-C3	EC251155	Mylar 0.033μF(K) 50WV	1	9-R50	ER212264	Carbon RD1/4 22k(J)	
9-C4	EC251190	Mylar 0.056μF(K) 50WV	1	9-R51	ER380711	Carbon RD1/4 220k(J)	
9-C5	EC362125	Mylar 0.0056μF(K) 50WV	1	9-R52	ER212477	Carbon RD1/4 3.3k(J)	
9-C6	EC538211	Elect. 3.3μF 16WV	1	9-R53, 54	ER211465	Carbon RD1/4 1k(J)	
9-C7, 8	EC250604	Mylar 0.001μF(K) 50WV	2	9-R55	ER212477	Carbon RD1/4 3.3k(J)	
9-C9	EC220151	Elect. 100μF 25WV	1	9-R56	ER336442	Carbon RD1/4 10k(J)	
9-C10	EC406800	Styrol 5600PF(G) 50WV (Tub. type)	1	9-R57	ER427241	Metal Oxide Film 2W 330(K)	
9-C11, 12	EC320051	Elect. 10μF 16WV	2	9-R58	ER211757	Carbon RD1/4 100k(J)	
9-C13	EC538244	Solid Aluminum 0.47μF(M) 10WV	1	9-R59	ER212264	Carbon RD1/4 22k(J)	
9-C14	EC220994	Elect. 10μF 25WV	1	9-R60	ER346601	Carbon RD1/4 47k(J)	
9-C15	EC538244	Solid Aluminum 0.47μF(M) 10WV	1	9-R61	ER211757	Carbon RD1/4 100k(J)	
9-C16	EC450055	Elect. 1μF 25WV	1	9-R62	ER304402	Carbon RD1/4 470(J)	
9-C17	EC336104	Elect. 100μF 6.3WV	1	9-R63	ER212016	Carbon RD1/4 150(J)	
9-C18	EC362125	Mylar 0.0056μF(K) 50WV	2	9-R64	ER554681	Carbon RD1/2 2.2(J) (Insu. type)	
9-C19	EC336115	Elect. 220μF 25WV	1	9-R65	ER419040	Carbon RD1/4 1M(J)	
9-C20	EC557155	Solid Aluminum 1μF(M) 10WV	1				
9-C21	EC251087	Mylar 0.022μF(K) 50WV	1				
Resistor, Stopper Type							
9-R1	ER211465	Carbon RD1/4 1k(J)	1				
9-R2	ER212681	Carbon RD1/4 330(J)	1				
9-R3	ER212477	Carbon RD1/4 3.3k(J)	1				
9-R4	ER343078	Carbon RD1/4 2.7k(J)	1				
9-R5	ER211320	Carbon RD1/4 1.5k(J)	1				
9-R6	ER336442	Carbon RD1/4 10k(J)	1				
9-R7	ER349907	Carbon RD1/4 33k(J)	1				
9-R8	ER430108	Carbon RD1/4 910(J)	1				
9-R9	ER357456	Carbon RD1/4 2.2k(J)	1				
9-R10	ER212477	Carbon RD1/4 3.3k(J)	1				
9-R11	ER304290	Carbon RD1/4 10(J)	1				
9-R12,13,14	ER336442	Carbon RD1/4 10k(J)	3				
9-R15	ER212264	Carbon RD1/4 22k(J)	1				
9-R16	ER349907	Carbon RD1/4 33k(J)	1				
9-R17	ER212264	Carbon RD1/4 22k(J)	1				
9-R18	ER212883	Carbon RD1/4 4.7k(J)	1				
9-R19, 20	ER212264	Carbon RD1/4 22k(J)	2				

When ordering parts, please describe Parts Number, Serial Number, and Model Number in detail.

FIG. 10 PHOTO OF SYS. CON. P.C. BOARD (TW-1048)

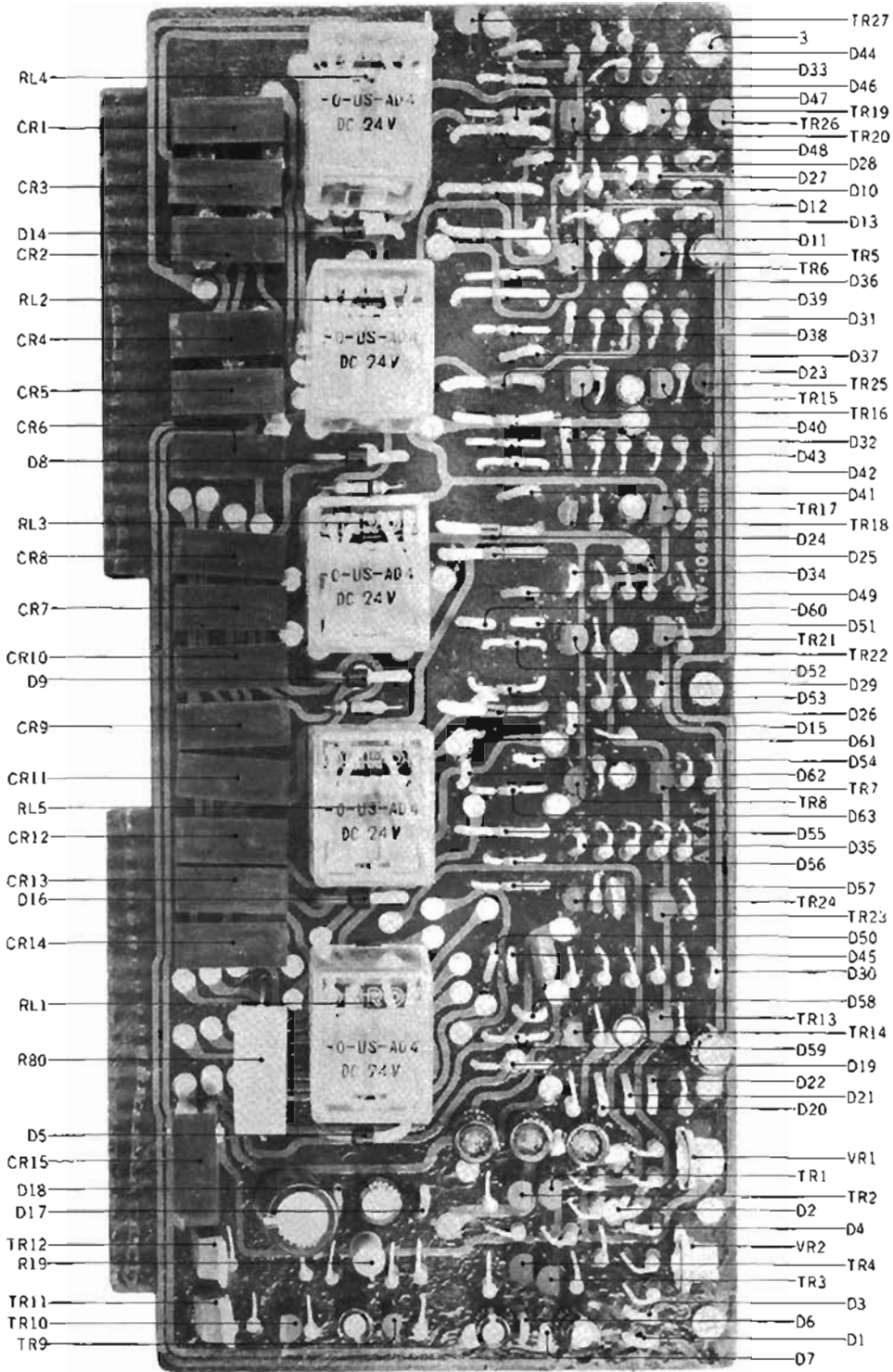

SYS. CON. P.C. BOARD (TW-1048) BLOCK

Symbol No.	Parts No.	Description	Q'ty	Symbol No.	Parts No.	Description	Q'ty
10-1x	BA552273	Sys. Con. P.C. Board Comp. (TW-1048)	1	10-R43	ER213030	Carbon RD1/4 5.6k(J)	1
10-RL1 to 5	EP344136	Relay MY4-O-US-AD4-24V	5	10-R44, 45	ER211465	Carbon RD1/4 1k(J)	2
10-TR1 to 7	ET453486	Transistor 2SC711(E)(F)	7	10-R46 to 55	ER212883	Carbon RD1/4 4.7k(J)	10
10-TR8, 9	ET511920	Transistor 2SC1247A(B)(V)	2	10-R56, 57	ER213030	Carbon RD1/4 5.6k(J)	2
10-TR10	ET453486	Transistor 2SC711(E)(F)	1	10-R58, 59	ER211465	Carbon RD1/4 1k(J)	2
10-TR11, 12	ET537300	Transistor 2SD361(D)(E)	2	10-R60, 61	ER213030	Carbon RD1/4 5.6k(J)	2
10-TR13	ET453486	Transistor 2SC711(E)(F)	1	10-R62, 63	ER211465	Carbon RD1/4 1k(J)	2
10-TR14	ET511920	Transistor 2SC1247A(B)(V)	1	10-R64, 65	ER213030	Carbon RD1/4 5.6k(J)	2
10-TR15,16,17	ET453486	Transistor 2SC711(E)(F)	3	10-R66, 67	ER211465	Carbon RD1/4 1k(J)	2
10-TR18	ET430907	Transistor 2SC1211(C)(D)	1	10-R68, 69	ER213030	Carbon RD1/4 5.6k(J)	2
10-TR19 to 23	ET453486	Transistor 2SC711(E)(F)	5	10-R70, 71	ER211465	Carbon RD1/4 1k(J)	2
10-TR24	ET511920	Transistor 2SC1247A(B)(V)	1	10-R72, 73	ER213030	Carbon RD1/4 5.6k(J)	2
10-TR25,26,27	ET538110	Transistor 2SA628(D)(E)	3	10-R74, 75	ER211465	Carbon RD1/4 1k(J)	2
10-D1 to 4	ED557447	Silicon Diode 1S1588	4	10-R76,77,78	ER357456	Carbon RD1/4 2.2k(J)	3
10-D5	ED494583	Silicon Diode 10D05	3	10-R79	ER346601	Carbon RD1/4 47k(J)	1
10-D6,7	ED557447	Silicon Diode 1S1588	2	10-R80	ER551924	Cement 5W 68(K) (Wire-wound type)	1
10-D8, 9	ED494583	Silicon Diode 10D05	2				
10-D10 to 13	ED557447	Silicon Diode 1S1588	4				
10-D14	ED494583	Silicon Diode 10D05	1				
10-D15	ED557447	Silicon Diode 1S1588	1				
10-D16	ED494583	Silicon Diode 10D05	1				
10-D17 to 22	ED557447	Silicon Diode 1S1588	6				
10-D23 to 26	ED494583	Silicon Diode 10D05	4				
10-D27 to 63	ED557447	Silicon Diode 1S1588	37				
10-VR1	EV497687	Semi-fixed Volume V10K8-1-5 50 kB(4US)	1				
10-VR2	EV513562	Semi-fixed Volume V10K8-1-5 100 kB(4US)	1				
10-CR1 to 15	ER376424	Spark Quencher U/L 0.1 μ +120 500WV	15				
10-2x	EZ534014	P.C. Board Angle	1				
10-3	ZW323728	Screw, binding head 3x5	3				
Capacitor, Vertical Type							
10-C1,2,3	EC456041	Elect. 33 μ F 25WV	3				
10-C4,5,6	EC220994	Elect. 10 μ F 25WV	3				
10-C7, 8	EC220432	Elect. 2.2 μ F 25WV	2				
10-C9	EC220612	Elect. 33 μ F 25WV	1				
10-C10	EC220994	Elect. 10 μ F 25WV	1				
10-C11	EC324538	Elect. 330 μ F 25WV	1				
10-C12	EC331705	Elect. 22 μ F 16WV	1				
10-C13	EC350684	Elect. 22 μ F 25WV	1				
10-C14 to 17	EC220432	Elect. 2.2 μ F 25WV	4				
10-C18	EC251155	Mylar 0.033 μ F(K) 50WV	1				
10-C19	EC251190	Mylar 0.056 μ F(K) 50WV	1				
Resistor, Stopper Type							
10-R1, 2	ER336442	Carbon RD1/4 10k(J)	2				
10-R3, 4	ER324641	Carbon RD1/4 1k(J) (Insu. type)	2				
10-R5	ER336442	Carbon RD1/4 10k(J)	1				
10-R6	ER357535	Carbon RD1/4 39k(J)	1				
10-R7	ER211465	Carbon RD1/4 1k(J)	1				
10-R8	ER362485	Carbon RD1/4 330k(J)	1				
10-R9	ER357570	Carbon RD1/4 150k(J)	1				
10-R10, 11	ER212883	Carbon RD1/4 4.7k(J)	1				
10-R12, 13	ER336442	Carbon RD1/4 10k(J)	2				
10-R14 to 18	ER212883	Carbon RD1/4 4.7k(J)	5				
10-R19	ER515125	Metal Oxide Film 2W 680(K)	1				
10-R20,21,22	ER212883	Carbon RD1/4 4.7k(J)	3				
10-R23, 24	ER357456	Carbon RD1/4 2.2k(J)	2				
10-R25, 26	ER211465	Carbon RD1/4 1k(J)	2				
10-R27, 28	ER213030	Carbon RD1/4 5.6k(J)	2				
10-R29, 30	ER211465	Carbon RD1/4 1k(J)	2				
10-R31	ER213030	Carbon RD1/4 5.6k(J)	1				
10-R32, 33	ER212883	Carbon RD1/4 4.7k(J)	2				
10-R34	ER357456	Carbon RD1/4 2.2k(J)	1				
10-R35	ER211465	Carbon RD1/4 1k(J)	1				
10-R36	ER336442	Carbon RD1/4 10k(J)	1				
10-R37	ER349907	Carbon RD1/4 33k(J)	1				
10-R38	ER212883	Carbon RD1/4 4.7k(J)	1				
10-R39, 40	ER211465	Carbon RD1/4 1k(J)	2				
10-R41	ER213030	Carbon RD1/4 5.6k(J)	1				
10-R42	ER211465	Carbon RD1/4 1k(J)	1				

When ordering parts, please describe Parts Number, Serial Number, and Model Number in detail.

FIG. 11 PHOTO OF SYS. CON. P.C. BOARD (TW-1201) (PRO)

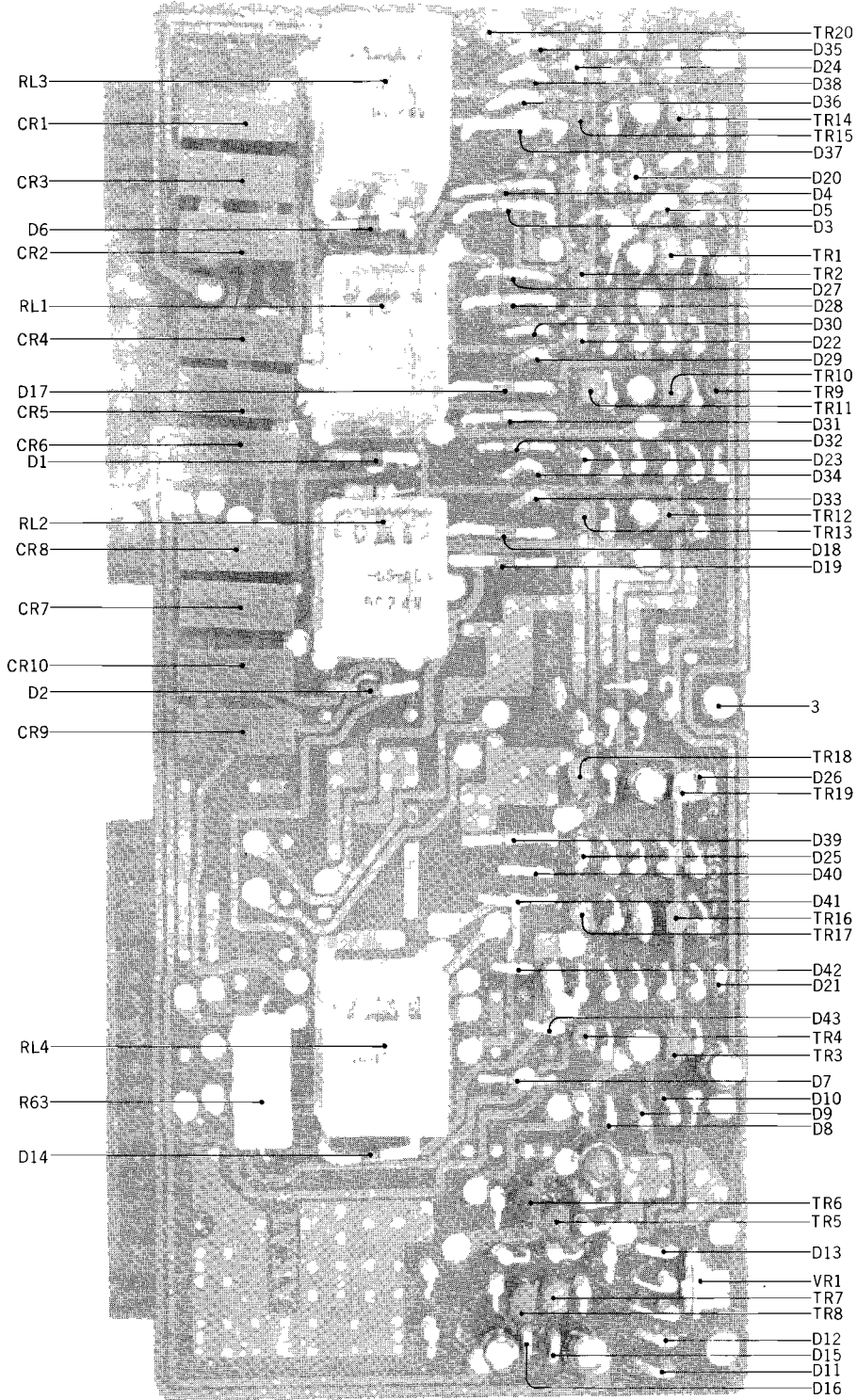

**SYS. CON. P.C. BOARD (TW-1201) BLOCK
(PRO)**

Symbol No.	Parts No.	Description	Q'ty	Symbol No.	Parts No.	Description	Q'ty
11-1x	BA552284	Sys. Con. P.C. Board Comp. (TW-1201) (PRO)	1	11-R27	ER336442	Carbon RD1/4 10k(J)	1
11-RL1 to 4	EP344136	Relay MY4-O-US-AD4-24V	4	11-R28	ER212883	Carbon RD1/4 4.7k(J)	1
11-TR1,2,3	ET453486	Transistor 2SC711(E)(F)	3	11-R29	ER357456	Carbon RD1/4 2.2k(J)	1
11-TR4	ET511920	Transistor 2SC1247A(B)(V)	2	11-R30 to 35	ER212883	Carbon RD1/4 4.7k(J)	6
11-TR5 to 8	ET453486	Transistor 2SC711(E)(F)	4	11-R36	ER357456	Carbon RD1/4 2.2k(J)	1
11-TR9	ET538110	Transistor 2SA628(D)(E)	1	11-R37, 38	ER212883	Carbon RD1/4 4.7k(J)	2
11-TR10,11,12	ET453486	Transistor 2SC711(E)(F)	3	11-R39	ER213030	Carbon RD1/4 5.6k(J)	1
11-TR13	ET430907	Transistor 2SC1211(C)(D)	1	11-R40	ER211465	Carbon RD1/4 1k(J)	1
11-TR14,15,16	ET453486	Transistor 2SC711(E)(F)	3	11-R41	ER213030	Carbon RD1/4 5.6k(J)	1
11-TR17	ET511920	Transistor 2SC1247A(B)(V)	1	11-R42	ER211465	Carbon RD1/4 1k(J)	1
11-TR18, 19	ET453486	Transistor 2SC711(E)(F)	2	11-R43	ER213030	Carbon RD1/4 5.6k(J)	1
11-TR20	ET538110	Transistor 2SA628(D)(E)	1	11-R44	ER211465	Carbon RD1/4 1k(J)	1
11-D1, 2	ED494583	Silicon Diode 10D05	2	11-R45	ER213030	Carbon RD1/4 5.6k(J)	1
11-D3,4,5	ED557447	Silicon Diode 1S1588	3	11-R46	ER211465	Carbon RD1/4 1k(J)	1
11-D6	ED494583	Silicon Diode 10D05	1	11-R47	ER213030	Carbon RD1/4 5.6k(J)	1
11-D7 to 13	ED557447	Silicon Diode 1S1588	7	11-R48	ER211465	Carbon RD1/4 1k(J)	1
11-D14	ED494583	Silicon Diode 10D05	1	11-R49	ER213030	Carbon RD1/4 5.6k(J)	1
11-D15, 16	ED557447	Silicon Diode 1S1588	2	11-R50	ER211465	Carbon RD1/4 1k(J)	1
11-D17,18,19	ED494583	Silicon Diode 10D05	3	11-R51	ER213030	Carbon RD1/4 5.6k(J)	1
11-D20 to 39	ED557447	Silicon Diode 1S1588	20	11-R52	ER211465	Carbon RD1/4 1k(J)	1
11-D42, 43	ED557447	Silicon Diode 1S1588	2	11-R53	ER213030	Carbon RD1/4 5.6k(J)	1
11-D44	ED555895	Zener Diode WZ-065	1	11-R54	ER346601	Carbon RD1/4 47k(J)	1
11-VR1	EV513562	Semi-fixed Volume V10K8-1-5 100 kB(4US)	1	11-R55	ER211465	Carbon RD1/4 1k(J)	1
11-CR1 to 10	ER376424	Spark Quencher U/L 0.1μ+120 500WV	10	11-R56	ER212883	Carbon RD1/4 4.7k(J)	1
11-2x	EZ534014	P.C. Board Angle	1	11-R57	ER336442	Carbon RD1/4 10k(J)	1
11-3	ZW323728	Screw, binding head 3x5	3	11-R58	ER212883	Carbon RD1/4 4.7k(J)	1
		Capacitor, Vertical Type		11-R59	ER336442	Carbon RD1/4 10k(J)	1
11-C1	EC220994	Elect. 10μF 25WV	1	11-R60	ER212264	Carbon RD1/4 22k(J)	1
11-C2	EC220432	Elect. 2.2μF 25WV	1	11-R61	ER336442	Carbon RD1/4 10k(J)	1
11-C3	EC331705	Elect. 22μF 16WV	1	11-R62	ER212883	Carbon RD1/4 4.7k(J)	1
11-C4	EC350684	Elect. 22μF 25WV	1	11-R63	ER551924	Cement 5W 68(K) (Wire-wound type)	1
11-C5	EC456041	Elect. 33μF 25WV	1				
11-C6, 7	EC220994	Elect. 10μF 25WV	2				
11-C8,9,10	EC220432	Elect. 2.2μF 25WV	3				
11-C11	EC251155	Mylar 0.033μF(K) 50WV	1				
11-C12	EC220994	Elect. 10μF 25WV	1				
11-C14	EC250885	Mylar 0.01μF(K) 50WV	1				
11-C15	EC251190	Mylar 0.056μF(K) 50WV	1				
11-C16	EC250885	Mylar 0.01μF(K) 50WV	1				
		Resistor, Stopper Type					
11-R1 to 5	ER212883	Carbon RD1/4 4.7k(J)	5				
11-R6	ER324641	Carbon RD1/4 1k(J)(Insu. type)	1				
11-R7,8,9	ER212883	Carbon RD1/4 4.7k(J)	3				
11-R10, 11	ER357456	Carbon RD1/4 2.2k(J)	2				
11-R12	ER211465	Carbon RD1/4 1k(J)	1				
11-R13	ER213030	Carbon RD1/4 5.6k(J)	1				
11-R14	ER211465	Carbon RD1/4 1k(J)	1				
11-R15	ER213030	Carbon RD1/4 5.6k(J)	1				
11-R16	ER211465	Carbon RD1/4 1k(J)	1				
11-R17	ER213030	Carbon RD1/4 5.6k(J)	1				
11-R18, 19	ER211465	Carbon RD1/4 1k(J)	2				
11-R20	ER336442	Carbon RD1/4 10k(J)	1				
11-R21	ER357535	Carbon RD1/4 39k(J)	1				
11-R22	ER211465	Carbon RD1/4 1k(J)	1				
11-R23	ER362485	Carbon RD1/4 330k(J)	1				
11-R24	ER357570	Carbon RD1/4 150k(J)	1				
11-R25	ER336442	Carbon RD1/4 10k(J)	1				
11-R26	ER212883	Carbon RD1/4 4.7k(J)	1				

When ordering parts, please describe Parts Number, Serial Number, and Model Number in detail.

FIG. 12 PHOTO OF P.B. AMP. P.C. BOARD (TW-5032)

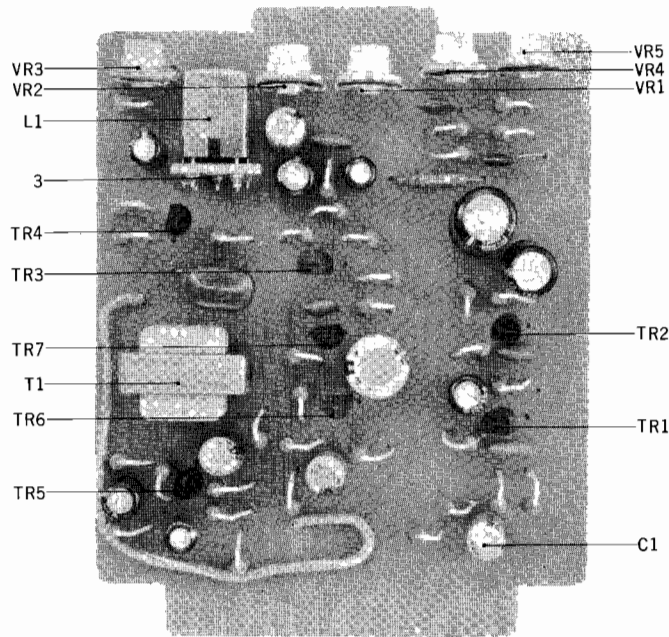

P.B. AMP. P.C. BOARD (TW-5032) BLOCK

Symbol No.	Parts No.	Description	Q'ty	Symbol No.	Parts No.	Description	Q'ty
12-1x	BA552532	P.B. Amp. P.C. Board Comp. (TW-5032)	1	Resistor, Stopper Type			
12-2x	BA552543	P.B. Amp. P.C. Board Comp. (TW-5032) (PRO)	1	12-R1	ER346601	Carbon RD1/4 47k(J)	1
12-TR1	ET459810	Transistor 2SC1222(E)(F)	1	12-R1	ER361528	Carbon RD1/4 56k(J) (PRO)	1
12-TR2	ET460912	Transistor 2SA640(L)(M)	1	12-R2	ER538413	Carbon RD1/4 1.3M(J)NL	1
12-TR3	ET459810	Transistor 2SC1222(E)(F)	1	12-R3	ER212477	Carbon RD1/4 3.3k(J)	1
12-TR4, 5	ET398788	Transistor 2SC945(R)	2	12-R4	ER427083	Carbon RD1/4 330k(J)NL	1
12-TR6	ET520277	Transistor 2SC1247A(B)	1	12-R5	ER424855	Carbon RD1/4 150k(J)NL	1
12-TR7	ET460912	Transistor 2SA640(L)(M)	1	12-R6	ER538424	Carbon RD1/4 120k(J)NL	1
12-VR1, 2	EV497687	Semi-fixed Volume V10K8-1-5 50 kΩ(4US)	2	12-R7	ER361563	Carbon RD1/4 180(J)	1
12-VR3	EV498060	Semi-fixed Volume V10K8-1-5 2 kΩ(4US)	1	12-R8	ER211858	Carbon RD1/4 12k(J)	1
12-VR4, 5	EV538402	Semi-fixed Volume V10K8-1-5 30 kΩ(4US)	2	12-R9	ER349942	Carbon RD1/4 8.2k(J)	1
12-L1	EO346230	Inductor RX 22MH	1	12-R10	ER427083	Carbon RD1/4 330k(J)NL	1
12-T1	BT247746	Head Phone Trans. N19-228S	1	12-R11	ER212883	Carbon RD1/4 4.7k(J)	1
12-3	EA496258	Inductor P.C. Board	1	12-R12	ER211757	Carbon RD1/4 100k(J)	1
Capacitor, Vertical Type				12-R13	ER426857	Carbon RD1/4 270k(J)	1
12-C1	EC557166	Solid Aluminum 3.3μF 25WV	1	12-R14	ER212477	Carbon RD1/4 3.3k(J)	1
12-C2	EC220590	Elect. 33μF 10WV	1	12-R15, 16	ER346601	Carbon RD1/4 47k(J)	2
12-C3	EC220105	Elect. 100μF 10WV	1	12-R17	ER357456	Carbon RD1/4 2.2k(J)	1
12-C4	EC220994	Elect. 10μF 25WV	1	12-R18	ER450011	Carbon RD1/4 120k(J)	1
12-C5	EC220151	Elect. 100μF 25WV	1	12-R19	ER213030	Carbon RD1/4 5.6k(J)	1
12-C6	EC450527	Elect. 4.7μF 25WV	1	12-R20	ER346994	Carbon RD1/4 18k(J)	1
12-C7	EC220590	Elect. 33μF 10WV	1	12-R21	ER211320	Carbon RD1/4 1.5k(J)	1
12-C8	EC336126	Elect. 47μF 25WV	1	12-R22	ER336442	Carbon RD1/4 10k(J)	1
12-C9	EC220994	Elect. 10μF 25WV	1	12-R23, 24	ER357456	Carbon RD1/4 2.2k(J)	2
12-C10	EC450527	Elect. 4.7μF 25WV	1	12-R25, 26	ER211757	Carbon RD1/4 100k(J)	2
12-C11	EC220432	Elect. 2.2μF 25WV	1	12-R27	ER357456	Carbon RD1/4 2.2k(J)	1
12-C12	EC220994	Elect. 10μF 25WV	1	12-R28	ER212477	Carbon RD1/4 3.3k(J)	1
12-C13	EC220590	Elect. 33μF 10WV	1	12-R29, 30	ER211757	Carbon RD1/4 100k(J)	2
12-C14	EC250841	Mylar 0.01μF(J) 50WV	1	12-R31	ER211320	Carbon RD1/4 1.5k(J)	1
12-C15	EC538435	Mylar 0.22μF(J) 50WV	1	12-R32	ER213096	Carbon RD1/4 510(J)	1
12-C16	EC336194	VFM 270PF(J) 50WV	1	12-R33	ER357456	Carbon RD1/4 2.2k(J)	1
12-C17	EC392332	VFM 82PF(J) 50WV	1	12-R34	ER346994	Carbon RD1/4 18k(J)	1
12-C18	EC399565	VFM 22PF(J) 50WV	1	12-R35	ER364961	Carbon RD1/4 1.2k(J)(Insu. type)	1
12-C19	EC350875	Mylar 0.001μF(J) 50WV	1	12-R36	ER550607	Carbon RD1/4 470k(J)NL	1
12-C19	EC389474	Mylar 0.0015μF(J) 50WV (PRO)	1				
12-C20	EC290520	VFM 100PF(J) 50WV	1				
12-C20	EC350616	VFM 50PF(J) 50WV (PRO)	1				

When ordering parts, please describe Parts Number, Serial Number, and Model Number in detail.

FIG. 13 PHOTO OF REC. & ADR P.C. BOARD (TW-5206)

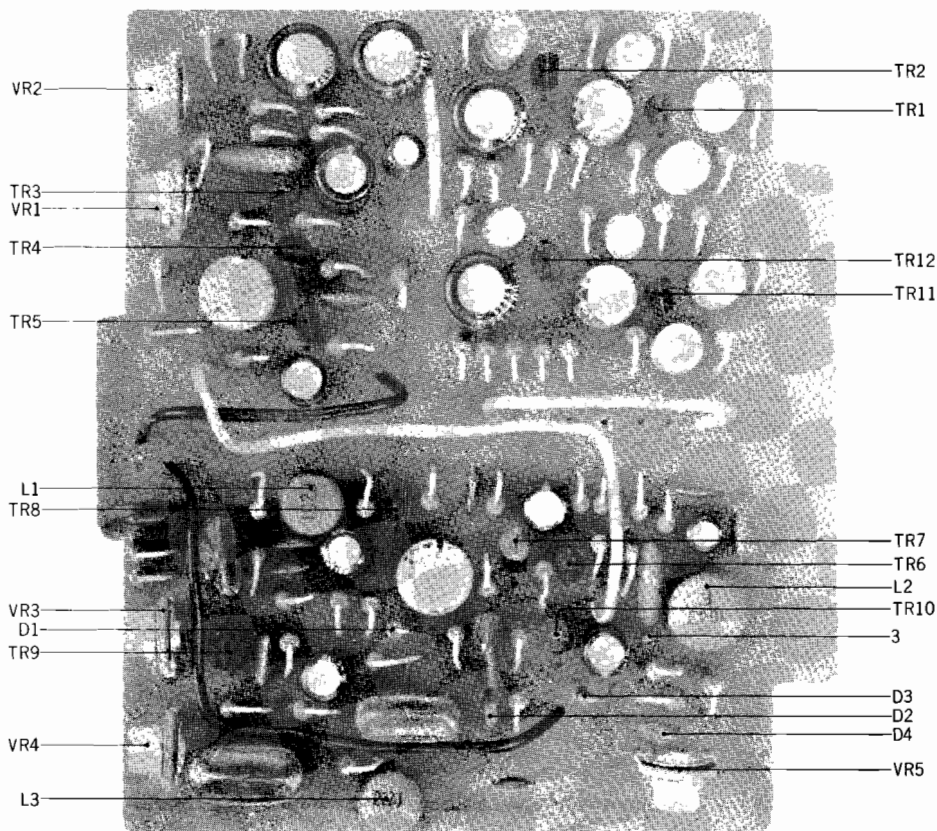

REC. & ADR P.C. BOARD (TW-5206) BLOCK

Symbol No.	Parts No.	Description	Q'ty	Symbol No.	Parts No.	Description	Q'ty
13-1x	BA552510	Rec. & ADR P.C. Board Comp. (TW-5206)	1	Capacitor, Vertical Type			
13-2x	BA552521	Rec. & ADR P.C. Board Comp. (TW-5206) (PRO)	1	13-C1, 2	EC517138	Elect. 10µF 25WVNL	2
13-TR1	ET495437	Transistor 2SC1222(F)	1	13-C3	EC514708	Elect. 4.7µF 25WVNL	1
13-TR2	ET444003	Transistor 2SA640(L)	1	13-C4	EC220364	Elect. 100µF 6.3WV	1
13-TR3	ET495437	Transistor 2SC1222(F)	1	13-C5	EC220151	Elect. 100µF 25WV	1
13-TR4	ET444003	Transistor 2SA640(L)	1	13-C6	EC514708	Elect. 4.7µF 25WVNL	1
13-TR5	ET495437	Transistor 2SC1222(F)	1	13-C7, 8	EC220151	Elect. 100µF 25WV	2
13-TR6	ET398788	Transistor 2SC945(R)	1	13-C9	EC350706	Elect. 4.7µF 16WV	1
13-TR7	ET538378	Transistor 2SA733(R)	1	13-C10	EC336216	VFM 330PF(J) 50WV	1
13-TR8	ET520277	Transistor 2SC1247A(B)	1	13-C11	EC450066	Elect. 33µF 16WV	1
13-TR9	ET234854	Transistor 2SC458LG(C)	1	13-C12	EC336126	Elect. 47µF 25WV	1
13-TR10	ET550798	FET 2SK30A	1	13-C13	EC290520	VFM 100PF(J) 50WV	1
13-TR11	ET495437	Transistor 2SC1222(F)	1	13-C14	EC220994	Elect. 10µF 25WV	1
13-TR12	ET444003	Transistor 2SA640(L)	1	13-C15	EC350706	Elect. 4.7µF 16WV	1
13-D1	ED219464	Germanium Diode 1N34A	1	13-C16	EC220994	Elect. 10µF 25WV	1
13-D2	ED515790	Silicon Diode WG713	1	13-C17	EC336126	Elect. 47µF 25WV	1
13-D3	ED491130	Zener Diode WZ085	1	13-C18	EC250683	Mylar 0.0022µF(J) 50WV	1
13-D4	ED219464	Germanium Diode 1N34A	1	13-C19	EC220994	Elect. 10µF 25WV	1
13-VR1, 2	EV538380	Semi-fixed Volume V10K8-1-5 10 kB(4US)	2	13-C20	EC337500	Mylar 0.0047µF(J) 50WV	1
13-VR2	EV538380	Semi-fixed Volume V10K8-1-5 10 kB(4US) (PRO)	1	13-C20	EC329883	Mylar 0.0056µF(J) 50WV(PRO)	1
13-VR3, 4	EV497698	Semi-fixed Volume V10K8-1-5 20 kB(4US)	2	13-C21	EC379765	Mylar 0.0027µF(J) 50WV	1
13-VR5	EV497700	Semi-fixed Volume V10K8-1-5 5 kB(4US)	1	13-C21	EC350875	Mylar 0.001µF(J) 50WV(PRO)	1
13-L1	EO443722	Ferri Inductor FL9H 1MH(J)	1	13-C22	EC379170	Mylar 0.1µF(J) 50WV	1
13-L2	EO538391	Ferri Inductor FL11H 100MH(J)	1	13-C23	EC290520	VFM 100PF(J) 50WV	1
13-L3	EO455883	Ferri Inductor FL9H 2.2MH(J)	1	13-C24	EC336521	Mylar 0.47µF(K) 50WV	1
13-3	EJ350447	Test Terminal	1	13-C25	EC220994	Elect. 10µF 25WV	1
				13-C26	EC454961	Elect. 0.33µF(J) 50WV	1
				13-C27	EC379170	Mylar 0.1µF(J) 50WV	1
				13-C28	EC220994	Elect. 10µF 25WV	1
				13-C29, 30	EC517138	Elect. 10µF 25WVNL	2
				13-C31	EC514708	Elect. 4.7µF 25WVNL	1
				13-C32	EC220364	Elect. 100µF 6.3WV	1
				13-C33	EC220151	Elect. 100µF 25WV	1
				13-C34	EC514708	Elect. 4.7µF 25WVNL	1
				13-C35	EC379787	Mylar 0.0039µF(J) 50WV	1

When ordering parts, please describe Parts Number, Serial Number, and Model Number in detail.

Symbol No.	Parts No.	Description	Q'ty
13-C36	EC290520	VFM 100PF(J) 50WV	1
13-C37	EC379170	Mylar 0.1 μ F(J) 50WV	1
13-C38	EC379721	Mylar 0.0012 μ F(J) 50WV	1
13-C38	EC516868	Styrol 430PF(J) 50WV (PRO)	1
13-C39	EC350717	VFM 390PF(J) 50WV	1
13-C40	EC379765	Mylar 0.0027 μ F(J) 50WV (PRO)	1
Resistor, Stopper Type			
13-R1	ER361563	Carbon RD1/4 180(J)	1
13-R2	ER346601	Carbon RD1/4 47k(J)	1
13-R3	ER561611	Carbon RD1/4 82k(J)NL	1
13-R4	ER212264	Carbon RD1/4 22k(J)	1
13-R5	ER349942	Carbon RD1/4 8.2k(J)	1
13-R6	ER352045	Carbon RD1/4 3.9k(J)	1
13-R7	ER429794	Carbon RD1/4 68(J)	1
13-R8	ER212264	Carbon RD1/4 22k(J)	1
13-R9	ER357491	Carbon RD1/4 82k(J)	1
13-R10	ER352045	Carbon RD1/4 3.9k(J)	1
13-R11	ER349942	Carbon RD1/4 8.2k(J)	1
13-R12	ER429794	Carbon RD1/4 68(J)	1
13-R13	ER211757	Carbon RD1/4 100k(J)	1
13-R14	ER357570	Carbon RD1/4 150k(J)	1
13-R15	ER212477	Carbon RD1/4 3.3k(J)	1
13-R16	ER538424	Carbon RD1/4 120k(J)NL	1
13-R17	ER306887	Carbon RD1/4 15k(J)	1
13-R18	ER450011	Carbon RD1/4 120k(J)	1
13-R19	ER211858	Carbon RD1/4 12k(J)	1
13-R20	ER357535	Carbon RD1/4 39k(J)	1
13-R21	ER352045	Carbon RD1/4 3.9k(J)	1
13-R22, 23	ER304402	Carbon RD1/4 470(J)	2
13-R24	ER211465	Carbon RD1/4 1k(J)	1
13-R25	ER212883	Carbon RD1/4 4.7k(J)	1
13-R26	ER306360	Carbon RD1/4 6.8k(J)	1
13-R27	ER362485	Carbon RD1/4 330k(J)	1
13-R28	ER450011	Carbon RD1/4 120k(J)	1
13-R29	ER212477	Carbon RD1/4 3.3k(J)	1
13-R30, 31	ER336442	Carbon RD1/4 10k(J)	2
13-R32, 33	ER357456	Carbon RD1/4 2.2k(J)	2
13-R34	ER306360	Carbon RD1/4 6.8k(J)	1
13-R35	ER211465	Carbon RD1/4 1k(J)	1
13-R36	ER336442	Carbon RD1/4 10k(J)	1
13-R37	ER306843	Carbon RD1/4 1.2k(J)	1
13-R38	ER213030	Carbon RD1/4 5.6k(J)	1
13-R39	ER211465	Carbon RD1/4 1k(J)	1
13-R40	ER450011	Carbon RD1/4 120k(J)	1
13-R41	ER346601	Carbon RD1/4 47k(J)	1
13-R42	ER343078	Carbon RD1/4 2.7k(J)	1
13-R43	ER363644	Carbon RD1/4 560(J)	1
13-R44	ER211465	Carbon RD1/4 1k(J)	1
13-R45	ER380913	Carbon RD1/4 33(J)	1
13-R46	ER306887	Carbon RD1/4 15k(J)	1
13-R47, 48	ER426857	Carbon RD1/4 270k(J)	2
13-R49	ER380711	Carbon RD1/4 220k(J)	1
13-R50	ER357456	Carbon RD1/4 2.2k(J)	1
13-R51	ER349942	Carbon RD1/4 8.2k(J)	1
13-R52	ER306843	Carbon RD1/4 1.2k(J)	1
13-R53	ER361563	Carbon RD1/4 180(J)	1
13-R54	ER346601	Carbon RD1/4 47k(J)	1
13-R55	ER561611	Carbon RD1/4 82k(J)NL	1
13-R56	ER212264	Carbon RD1/4 22k(J)	1
13-R57	ER349942	Carbon RD1/4 8.2k(J)	1
13-R58	ER352045	Carbon RD1/4 3.9k(J)	1
13-R59	ER429794	Carbon RD1/4 68(J)	1
13-R60	ER212264	Carbon RD1/4 22k(J)	1
13-R61	ER357491	Carbon RD1/4 82k(J)	1
13-R62	ER352045	Carbon RD1/4 3.9k(J)	1
13-R63	ER349942	Carbon RD1/4 8.2k(J)	1
13-R64	ER429794	Carbon RD1/4 68(J)	1
13-R65	ER346601	Carbon RD1/4 47k(J)	1
13-R66	ER211465	Carbon RD1/4 1k(J)	1
13-R67	ER346994	Carbon RD1/4 18k(J)	1
13-R68	ER361528	Carbon RD1/4 56k(J)	1
13-R69	ER212883	Carbon RD1/4 4.7k(J) (PRO)	1
13-R70	ER336442	Carbon RD1/4 10k(J) (PRO)	1

When ordering parts, please describe Parts Number, Serial Number, and Model Number in detail.

**FIG. 14 PHOTO OF
OSC. P.C. BOARD (TW-5033)**

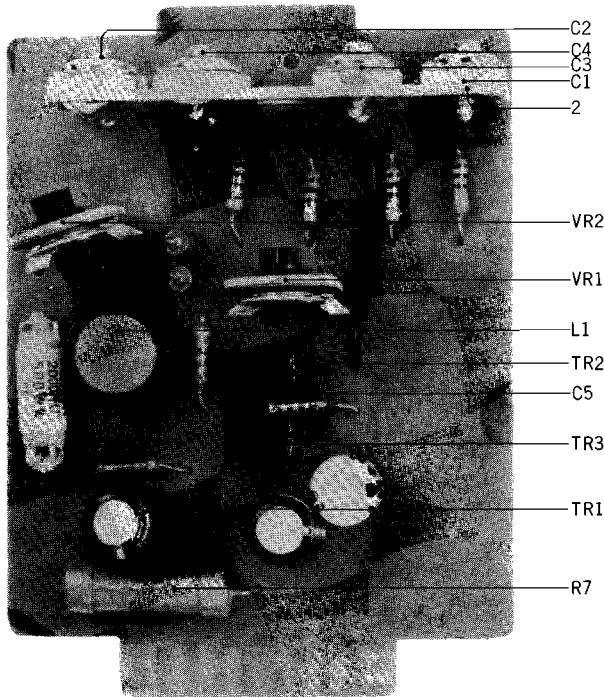

**FIG. 15 PHOTO OF OSC. P.C. BOARD
(TW-5204) (PRO)**

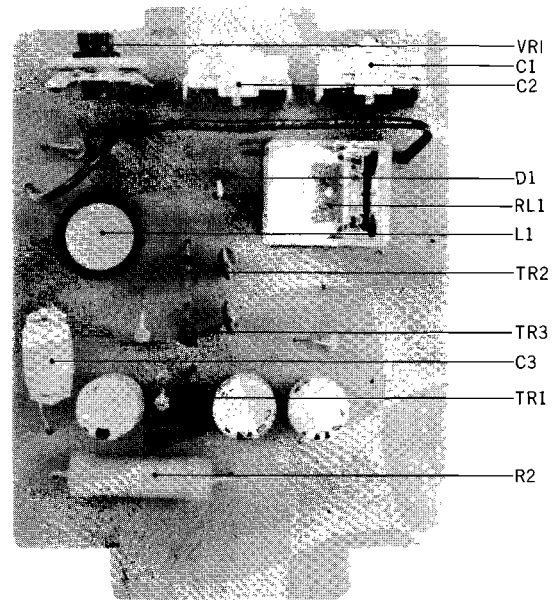

OSC. P.C. BOARD (TW-5033) BLOCK

Symbol No.	Parts No.	Description	Q'ty
14-1x	BA552497	OSC. P.C. Board Comp. (TW-5033)	1
14-TR1,2,3	ET520288	Transistor 2SC1247A(V)	3
14-L1	EO383365	OSC. Coil OT-204	1
14-VR1, 2	EV496271	Semi-fixed Volume V18K32 2 kB(4US)	2
14-2	EA534148	Trimmer P.C. Board	1
Capacitor, Vertical Type			
14-C1 to 4	EC398878	Trimmer C-1P-2 50 to 70PF	4
14-C5	EC246137	Plastic Film 2000PF(J) 500WV	1
14-C6, 7	EC335452	Elect. 100μF 25WV	2
14-C8	EC336126	Elect. 37μF 25WV	1
14-C9, 10	EC250841	Mylar 0.01μF(J) 50WV	2
Resistor, Insulator Type			
14-R1 to 4	ER324808	Carbon RD1/4 100(J)	4
14-R5, 6	ER538301	Solid RC1/2 56(K)	2
14-R7	ER538345	Metal Oxide Film 3W 150(K)	1
14-R8	ER329264	Carbon RD1/4 2.2k(J)	1
14-R9	ER324685	Carbon RD1/4 33k(J)	1
14-R10	ER430200	Carbon RD1/4 3.3(J)	1

OSC. P.C. BOARD (TW-5204) BLOCK (PRO)

Symbol No.	Parts No.	Description	Q'ty
15-1x	BA552508	OSC. P.C. Board Comp. (TW-5204) (PRO)	1
15-TR1,2,3	ET520288	Transistor 2SC1247A(V)	3
15-VR1	EV496271	Semi-fixed Volume V18K32 2 kB(4US)	1
15-RL1	EP383321	Relay TECK-36 DC22V1000	1
15-L1	EO383365	OSC. Coil OT-204	1
15-D1	ED224526	Silicon Diode 10D1	1
Capacitor, Vertical Type			
15-C1, 2	EC425250	Trimmer A-1P3-3 70PF	2
15-C3	EC446242	Plastic Film 1500PF(J) 500WV	1
15-C4, 5	EC335452	Elect. 100μF 25WV	2
15-C6	EC336126	Elect. 47μF 25WV	1
15-C7, 8	EC250841	Mylar 0.01μF(J) 50WV	2
Resistor, Stopper Type			
15-R1	ER538301	Solid RC1/2 56(K)	1
15-R2	ER538345	Metal Oxide Film 3W 150(K)	1
15-R3	ER357456	Carbon RD1/4 2.2k(J)	1
15-R4	ER349907	Carbon RD1/4 33k(J)	1
15-R5	ER315944	Carbon RD1/4 3.3(J)	1

FIG. 16 PHOTO OF DIRECTION
P.C. BOARD (TW-2057)

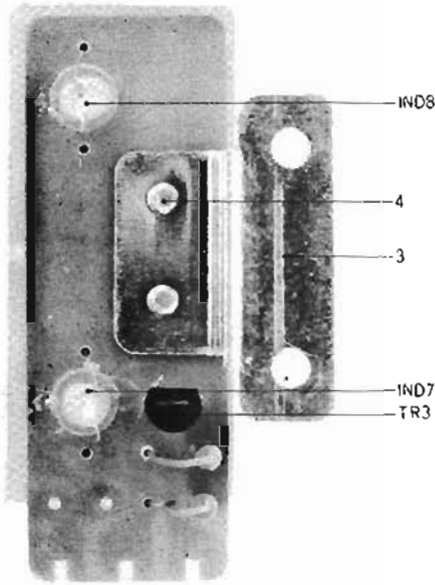
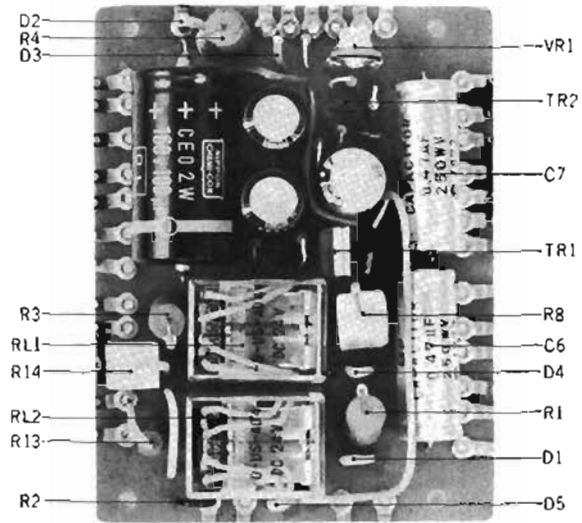

FIG. 17 PHOTO OF POWER SUPPLY
P.C. BOARD (TW-2018)



DIRECTION P.C. BOARD (TW-2057) BLOCK

Symbol No.	Parts No.	Description	Q'ty
16-1x	BA552352	Direction P.C. Board Comp. (TW-2057)	1
16-TR3	ET379462	Transistor 2SC711(D)(E)	1
16-IND7, 8	EL390576	Pilot Lamp RM6-24V-50MA (Lead type)	1
16-2x	EZ534892	Direction House	1
16-3	EZ534870	Direction Table	1
16-4	ZW417194	Screw, binding head 3x10	2
Resistor, Stopper Type			
16-R3	ER213030	Carbon RD1/4 5.6k(J)	1
16-R4	ER211465	Carbon RD1/4 1k(J)	1

**POWER SUPPLY P.C. BOARD (TW-2018)
BLOCK**

Symbol No.	Parts No.	Description	Q'ty
17-1x	BA552262	Power Supply P.C. Board Comp. (TW-2018)	1
17-TR1	ET418871	Transistor 2SC1014(C)(D)	1
17-TR2	ET511920	Transistor 2SC1247A(B)(V)	1
17-D1, 2	ED224550	Silicon Diode 10D4	2
17-D3	ED538042	Zener Diode RD-7A(L)	1
17-D4, 5	ED224526	Silicon Diode 10D1	2
17-VR1	.EV498071	Semi-fixed Volume V10K8-1-5 1 k(4US)	1
17-RL1, 2	EP344136	Relay MY4-O-US-AD4-24V	2
Capacitor, Vertical Type			
17-C1	EC372148	Elect. 220μF 35WV	1
17-C2	EC316091	Elect. 100μF 160WV(Tub. type)	1
17-C3	EC372148	Elect. 220μF 35WV	1
17-C4	EC350875	Mylar 0.001μF(J) 50WV	1
17-C5	EC336115	Elect. 220μF 25WV	1
17-C6, 7	EC350987	MP 0.47μF(M) 250VAC(Tub. type)	2
Resistor, Stopper Type			
17-R1	ER538086	Wire-wound 3W 2.2(K)(P type)	1
17-R2	ER551878	Metal Oxide Film 1W 27(K)	1
17-R3	ER539010	Metal Oxide Film 3W 33(K)	1
17-R4	ER538086	Wire-wound 3W 2.2(K)(P type)	1
17-R5	ER306843	Carbon RD1/4 1.2k(J)	1
17-R6	ER211465	Carbon RD1/4 1k(J)	1
17-R7	ER212681	Carbon RD1/4 330(J)	1
17-R8	ER538097	Cement SW 2.5k(K) (Metal Ox. Film type)	1
17-R9	ER336442	Carbon RD1/4 10k(J)	1
17-R10	ER211465	Carbon RD1/4 1k(J)	1
17-R11	ER213096	Carbon RD1/4 510(J)	1
17-R12	ER362441	Carbon RD1/4 1.8k(J)	1
17-R13	ER550596	Metal Oxide Film 2W 27(K)	1
17-R14	ER554556	Cement SW 39(K) (Wire-wound type)	1

When ordering parts, please describe Parts Number, Serial Number, and Model Number in detail.

FIG. 18 PHOTO OF EQUALIZER SWITCH P.C. BOARD (TW-5028)

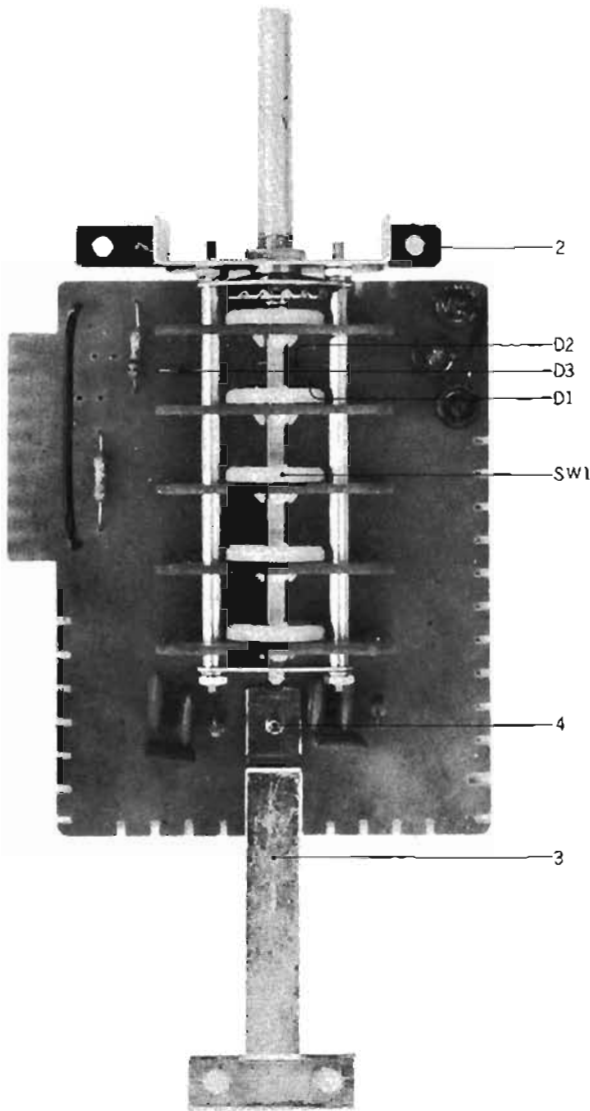

EQUALIZER SWITCH P.C. BOARD (TW-5028) BLOCK

Symbol No.	Parts No.	Description	Q'ty
18-1x	BA552576	Equalizer Switch P.C. Board Comp. (TW-5028)	1
18-D1,2,3	ED515790	Silicon Diode WG713	3
18-SW1	ES538446	Rotary Switch EP-5203	1
18-2	EZ535331	Equalizer Switch Retaining Plate	1
18-3	EZ534172	T type Angle	1
18-4	ZW447772	Tapping Screw #2 3x6(BR)	1
Capacitor, Vertical Type			
18-C1,2,3	EC456041	Elect. 33 μ F 25WV	3
18-C5	EC350638	VFM 180PF(J) 50WV	1
18-C6	EC389237	VFM 200PF(J) 50WV	1
18-C7, 8	EC350638	VFM 180PF(J) 50WV	2
18-C9	EC389237	VFM 200PF(J) 50WV	1
18-C10	EC350638	VFM 180PF(J) 50WV	1
Resistor, Insulator Type			
18-R1	ER345712	Carbon RD1/4 22k(J)	1
18-R2	ER324641	Carbon RD1/4 1k(J)	1
18-R3, 4	ER347073	Carbon RD1/4 200(J) (Stopper Type)	2

FIG. 19 PHOTO OF T.S. P.C. BOARD (TW-5026)

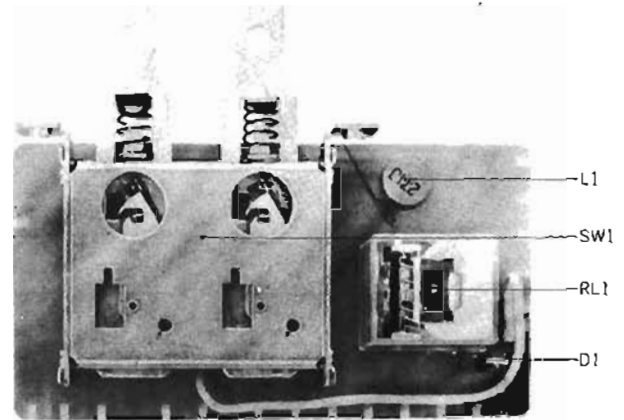

T.S. P.C. BOARD (TW-5026) BLOCK

Symbol No.	Parts No.	Description	Q'ty
19-1x	BA552442	T.S. P.C. Board Comp. (TW-5026)	1
19-SW1	ES538323	Push Switch SPM-025D	1
19-RL1	EP383321	Relay TECK-3 ϕ DC22V1000	1
19-L1	EO488430	Ferri Inductor FL9H 270 μ H(J)	1
19-D1	ED224526	Silicon Diode 10D1	1

FIG. 20 PHOTO OF P.B. MODE P.C. BOARD (TW-5203)

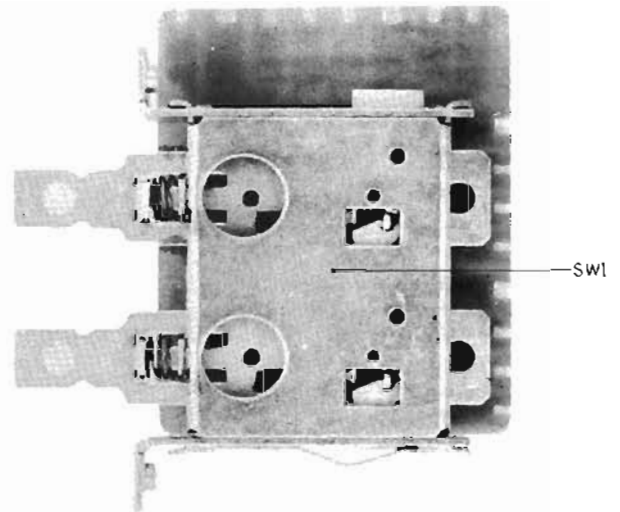

P.B. MODE P.C. BOARD (TW-5203) BLOCK

Symbol No.	Parts No.	Description	Q'ty
20-1x	BA552453	P.B. Mode P.C. Board Comp. (TW-5203)	1
20-SW1	ES538312	Push Switch SPM-025A21	1

FIG. 21 PHOTO OF MONITOR SWITCH
P.C. BOARD (TW-5027)

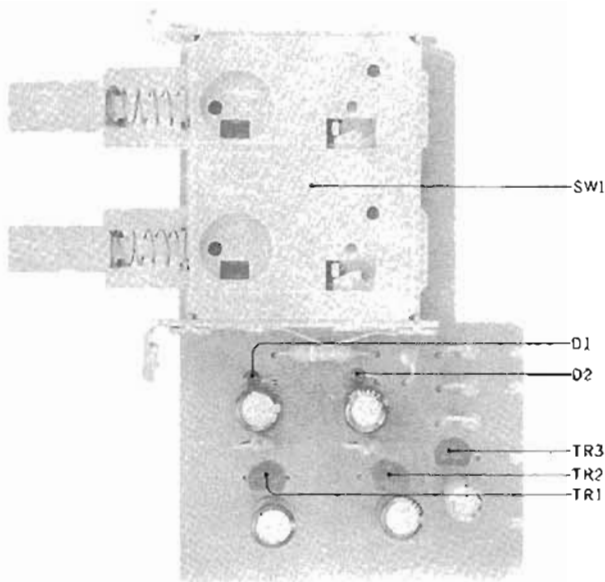
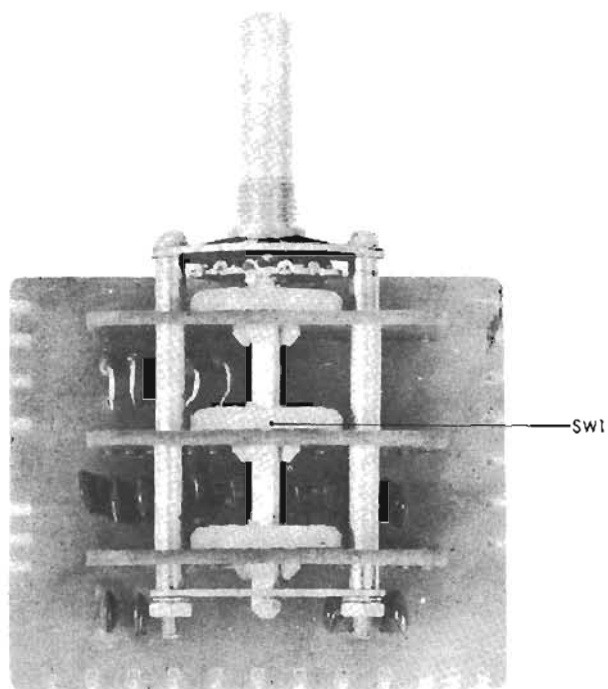

FIG. 22 PHOTO OF SRT SWITCH
P.C. BOARD (TW-5029)



MONITOR SWITCH P.C. BOARD
(TW-5027) BLOCK

Symbol No.	Parts No.	Description	Q'ty
21-1x	BA552431	Monitor Switch P.C. Board Comp. (TW-5027)	1
21-SW1	ES538312	Push Switch SPM-025A21	1
21-TR1,2,3	ET380834	Transistor 2SC711(E)	3
21-D1, 2	ED384096	Zener Diode RD-9A	2
		Capacitor, Vertical Type	
21-C1, 2	EC220612	Elect. 33 μ F 25WV	2
21-C3, 4	EC220994	Elect. 10 μ F 25WV	2
21-C5	EC450527	Elect. 4.7 μ F 25WV	1
		Resistor, Stopper Type	
21-R1, 2	ER429996	Carbon RD1/4 470k(J)	2
21-R3	ER211465	Carbon RD1/4 1k(J)	1
21-R4	ER213030	Carbon RD1/4 5.6k(J)	1
21-R5	ER357456	Carbon RD1/4 2.2k(J)	1
21-R6	ER357535	Carbon RD1/4 39k(J)	1
21-R7	ER364994	Carbon RD1/4 39k(J)	1

SRT SWITCH P.C. BOARD (TW-5029) BLOCK

Symbol No.	Parts No.	Description	Q'ty
22-1x	BA552464	SRT Switch P.C. Board Comp. (TW-5029)	1
22-2x	BA552475	SRT Switch P.C. Board Comp. (TW-5029)(PRO)	1
22-SW1	ES538334	Rotary Switch EP-3122A	1
		Capacitor, Vertical Type	
22-C1, 2	EC350875	Mylar 0.001 μ F(J) 50WV	2
22-C1, 2	EC389474	Mylar 0.0015 μ F(J) 50WV(PRO)	2
22-C3, 4	EC350875	Mylar 0.001 μ F(J) 50WV	2
22-C3, 4	EC379721	Mylar 0.0012 μ F(J) 50WV(PRO)	2
22-C5, 6	EC250683	Mylar 0.0022 μ F(J) 50WV	2
22-C5, 6	EC424708	Mylar 0.0018 μ F(J) 50WV(PRO)	2
22-C7, 8	EC337500	Mylar 0.0047 μ F(J) 50WV	2
22-C7, 8	EC250683	Mylar 0.0022 μ F(J) 50WV(PRO)	2
22-C9, 10	EC329883	Mylar 0.0056 μ F(J) 50WV	2
22-C9, 10	EC379765	Mylar 0.0027 μ F(J) 50WV(PRO)	2
22-C11, 12	EC350875	Mylar 0.001 μ F(J) 50WV(PRO)	2
		Resistor, Stopper Type	
22-R1, 2	ER213120	Carbon RD1/4 56(J)	2
22-RJ, 4	ER433877	Carbon RD1/4 120(J)	2

FIG. 23 PHOTO OF CHASSIS P.C. BOARD (TW-5025)

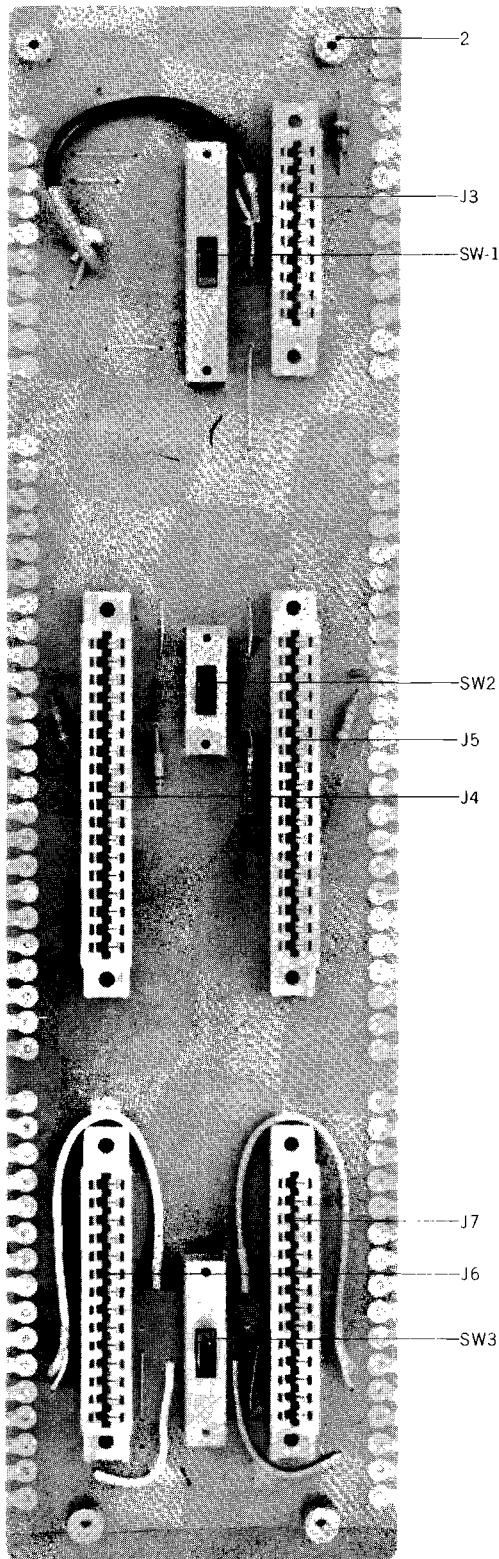

CHASSIS P.C. BOARD (TW-5025) BLOCK

Symbol No.	Parts No.	Description	Q'ty
23-1x	BA552486	Chassis P.C. Board Comp. (TW-5025)	1
23-SW1	ES538277	Slide Switch SSB08204	1
23-SW2	ES538255	Slide Switch SSB04208	1
23-SW3	ES538266	Slide Switch SSB06204	1
23-J1	EJ293084	14P Multi-jack-1 3250-014-098	1
23-J2	EJ292926	10P Multi-jack 3250-014-098	1
23-J3	EJ482793	10P Multi-jack 3250-010-001	1
23-J4, 5	EJ310871	18P Multi-jack J-2 3250-018-001	2
23-J6, 7	EJ368785	14P Multi-jack 3250-014-001	2
23-2	MH534183	Connector Prop.	4
23-3x	ZW413741	Screw, binding head 3x8	4
23-C1, 2	EC379765	Mylar Capacitor 0.0027μF(J) 50WV	2
Resistor, Insulator Type			
23-R1, 2	ER214290	Carbon RD1/4 4.7k(J)	2
23-R3, 4	ER213647	Carbon RD1/4 10k(J)	2
23-R5	ER538301	Solid RC1/2 56(K)	1

FIG. 24 PHOTO OF AMPLIFIER ASSEMBLY BLOCK

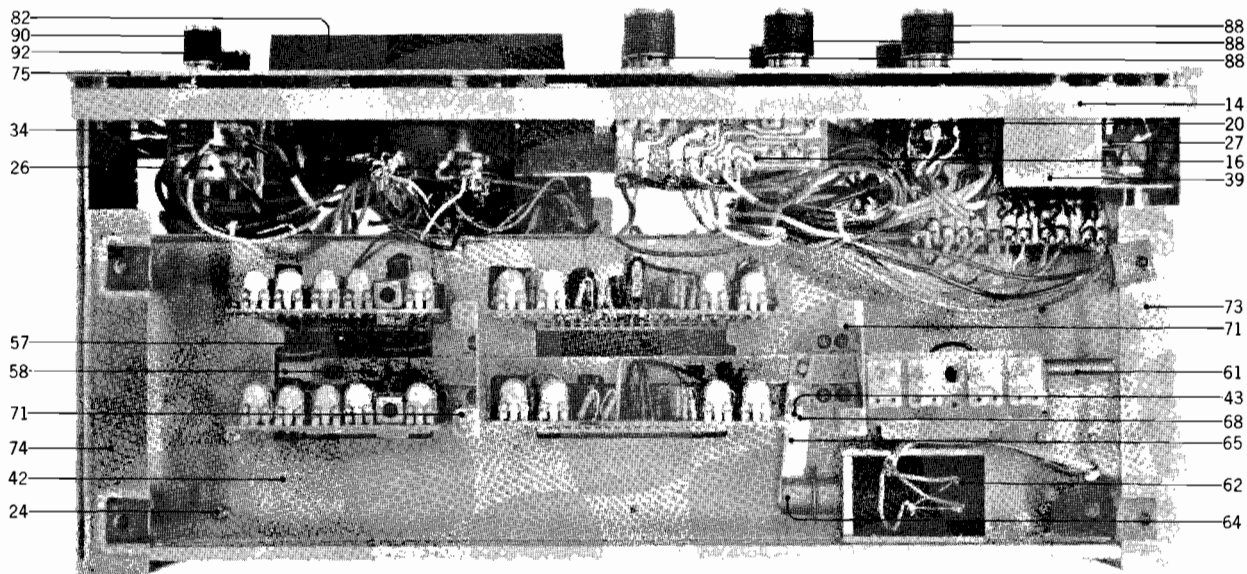
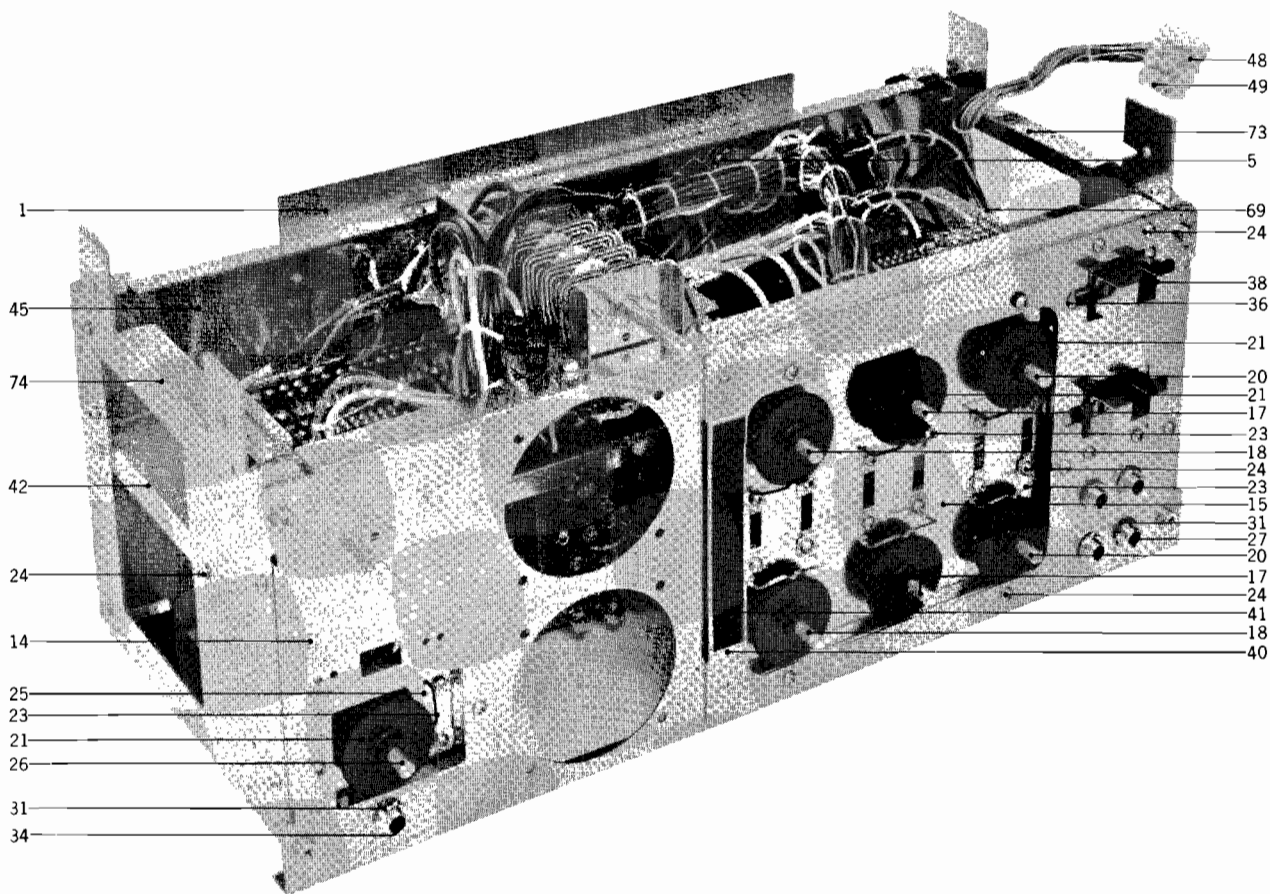

AMPLIFIER ASSEMBLY BLOCK

Ref. No.	Parts No.	Description	Schematic No.	Q'ty	Ref. No.	Parts No.	Description	Schematic No.	Q'ty	
JACK PLATE BLOCK										
24-1	BZ552554	Jack Plate Block Comp.	TW-1	1	24-54x	MH534183	Connector Prop	TW-5039	2	
24-2x	BZ552565	Jack Plate Block Comp.			24-55x	ZW413741	Screw, binding head 3x8		2	
		(PRO)	TW-2	1	24-56x	EJ255115	Lug Plate VB2L2	33-4-3	1	
24-3x	EJ457661	Terminal A (PRO)	55-5032	1	24-57	EZ535364	Lever A, w/pin	TW-5011	1	
24-4x	EJ457637	Terminal B (PRO)	55-5033	1	24-58	ZW553983	Screw, pan head 2.6x6		2	
24-5	ES539177	Rotary Switch SR-25N			24-59x	ZW535397	Graduated Washer	TW-5014	2	
		1-2-3 12.5S	25-6-60	1	24-60x	ZW550697	Washer (SPC)D2.9x7.5x0.5t		2	
24-6x	SK245182	Brake Change Knob	RD-622	1	24-61	ZG535443	Return Spring	TW-5019	1	
24-7x	ER364948	Carbon/R. RD1/4 3.3k(J)			24-62	EP538468	Plunger Solenoid 1660PHT	44-1-55	1	
		(Insu. type)	35-9-5	2	24-63x	ED224550	Silicon Diode 10D4	45-2-16	2	
24-8x	ER324685	Carbon/R. RD1/4 33k(J)			24-64	ZW533913	Connecting Pin	TW-2010	1	
		(Insu. type)	35-9-5	4	24-65	EZ535375	Lever B	TW-5012	1	
24-9x	ER345756	Carbon/R. RD1/4 68k(J)			24-66x	ZW270088	'E' Ring 1.9M	6-1-9	1	
		(Insu. type)	35-9-5	4	24-67x	ZW394086	Washer (Nylon)D4.1x7x1t		1	
24-10x	ER213647	Carbon/R. RD1/4 10k(J)			24-68	ZW290283	'U' Ring 2.85M	6-1-1	1	
		(Insu. type)	35-9-5	6	24-69	EZ328320	Nylon Clip HP-5N	2-7-39	1	
24-11x	ES564748	Slide Switch #101 S-J0282		1	24-70x	EJ315101	Nylon Clip HP-4N	2-7-38	1	
24-12x	EJ255115	Lug Plate VB2L2	33-4-3	1	24-71	EZ535342	P.C. Board Retaining Table	TW-5009	2	
24-13x	ZW419782	Screw, binding head 2.6x5		2	24-72x	EZ535353	P.C. Board Retainer	TW-5010	1	
AMP. ASSEMBLY BLOCK										
24-14	EZ532293	Amp. Chassis A, w/prop	TW-5001	1	24-73	EZ535285	Amp. Side Plate (R)	TW-5004	1	
24-15	EZ535410	Volume Chassis A	TW-5016	1	24-74	EZ535296	Amp. Side Plate (L)	TW-5004	1	
24-16	EA534137	Volume P.C. Board	TW-5030	2	24-75	SP546895	Amp. Panel C	TW-5021	1	
24-17	EV538492	Co-axial 2-throw/Vol.			24-76x	SP535465	Amp. Panel A (black)	TW-5021	1	
		G24R-50kAx2	36-1-30	2	24-77x	SP535476	Amp. Panel B (PRO)	TW-5021	1	
24-18	EV538503	Volume V24R-50 kA	36-2-35	2	24-78x	SE535487	Push Button Escutcheon	TW-5023	2	
24-19x	ER329308	Carbon/R. RD1/4 47k(J)			24-79x	EZ535498	Escutcheon Holder	TW-5024	1	
		(Insu. type)	35-9-5	6	24-80x	ZW339502	Tapping Screw #2 3x5(round)		2	
24-20	EV538514	Volume V24E-50 kB	36-2-36	2	24-81x	ZW553972	Washer(Nylon)D6.2x1 3x0.8t		17	
24-21	EZ535432	Click Gear	TW-5018	7	24-82	EM550721	VU Meter R-65-438B10-1	(yellow)	46-2-18	2
24-22x	ZW434160	Set Screw, hexagon socket			24-83x	EM550710	VU Meter R-65-438B6-1 (blue)	46-2-17	2	
		3x3(cup)		14	24-84x	ZW203174	Screw, oval countersunk		4	
24-23	ZG535454	Click Spring	TW-5020	7			head 4x8(black)		4	
24-24	ZW447772	Tapping Screw #2 3x6(BR)		56	24-85x	ZW301184	Screw, oval countersunk		4	
24-25	EZ535421	Volume Chassis B	TW-5017	1			head 4x8		4	
24-26	EV538481	Co-axial 2-throw/Vol.			24-86x	SZ534385	Panel Washer A	TW-6021	4	
		G24N-50kAx2	36-1-27	1	24-87x	SZ534396	Panel Washer B (black)	TW-6021	4	
24-27	EJ437310	Mic. Jack 2PMJ1P	31-2-37	4	24-88	SK534431	Amp. Knob A	TW-6025	6	
24-28x	ER364948	Carbon/R. RD1/4 3.3k(J)			24-89x	ZW433001	Set Screw, hexagon socket		6	
		(Insu. type)	35-9-5	2			3x5(cup)		6	
24-29x	ER324641	Carbon/R. RD1/4 1k(J)			24-90	SK534442	Amp. Knob B	TW-6026	1	
		(Insu. type)	35-9-5	2	24-91x	ZW434160	Set Screw, hexagon socket		2	
24-30x	EZ225180	Nylon Collar, Jack	LD-520	4			3x3(cup)		2	
24-31	ZW561655	E Jack Nut		5	24-92	SK534418	Selector Knob B	TW-6023	1	
24-32x	EZ436217	Collar, Jack	MC-5006	5	24-93x	ZW462194	Tapping Screw #2 3x8(pan),		2	
24-33x	ZW455275	Washer (Fiber)D9.1x18x0.5t		5			w/washer		2	
24-34	EJ437321	3-P Molded-jack 3PMJ1P	31-2-38	1						
24-35x	ZW272722	M9 Toothed Lock Washer								
		D9.3x1 3x0.5t		1						
24-36	EZ535318	Switch Retaining Plate	TW-5006	1						
24-37x	ZW371856	ISO Screw, binding head 3x5		8						
24-38	SK534161	Push Knob	TW-5037	4						
24-39	EZ531854	Shield Box	TW-5040	1						
24-40	EZ535307	Panel Support	TW-5005	1						
24-41	EZ541451	Amp. Panel Cloth	TW-5051	1						
24-42	EZ532304	Amp. Chassis B	TW-5002	1						
24-43	ZW535320	Pin A	TW-5007	1						
24-44x	ZW273756	Nut M3		1						
24-45	EZ535274	Amp. Chassis C	TW-5003	1						
24-46x	ZW447805	Tapping Screw #2 3x12(BR)		20						
24-47x	ZW323728	Screw, binding head 3x5		6						
24-48	EJ293062	12P Mate-N-Lock Cap								
		Housing 1-480278-0	52-1-1	1						
24-49	EJ373623	Pin Contact 61116-1	52-1-1	10						
24-50x	EJ373691	9P Mate-N-Lock Cap								
		Housing 1-480277-0(PRO)	52-1-2	1						
24-51x	EJ368785	14P Multi-jack								
		3250-014-001 (PRO)	31-4-14	3						
24-52x	EJ310871	18P Multi-jack J-2								
		3250-018-001 (PRO)	31-4-11	2						
24-53x	EJ482793	10P Multi-jack								
		3250-010-001 (PRO)	31-4-21	1						

When ordering parts, please describe Parts Number, Serial Number, and Model Number in detail.

FIG. 25 PHOTO OF FINAL ASSEMBLY BLOCK

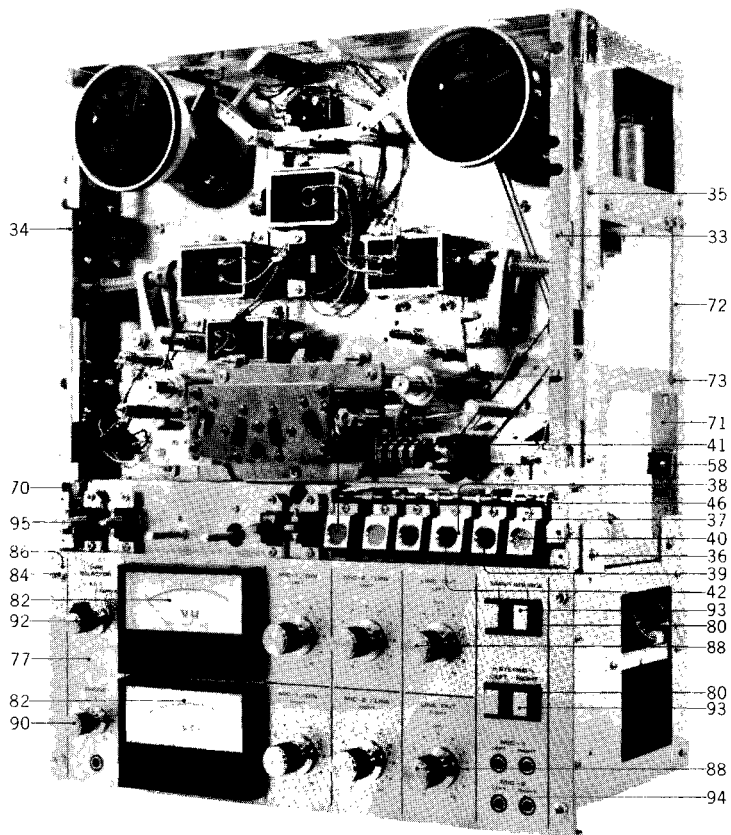
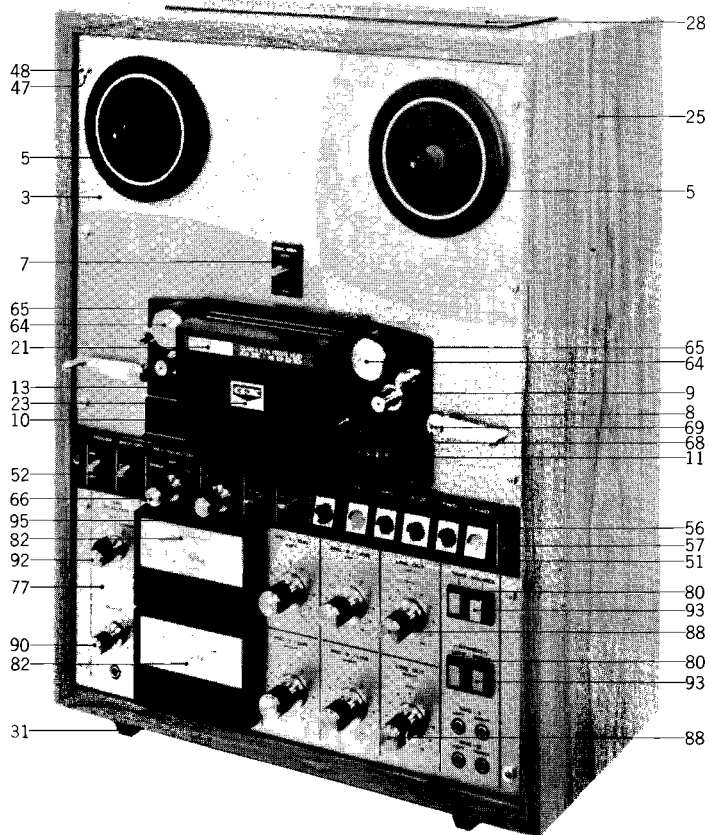

FINAL ASSEMBLY BLOCK

Ref. No.	Parts No.	Description	Schematic No.	Q'ty	Ref. No.	Parts No.	Description	Schematic No.	Q'ty
MECH. PANEL BLOCK					25-59x	SZ377190	LM Rubber Foot	LM-404	4
25-1x	BZ552071	Mech. Panel Block Comp.	TW-1	1	25-60x	ZW419646	Washer (SPC)D4.5x9.8x0.5t		4
25-2x	BZ552082	Mech. Panel Block Comp. (PRO)	TW-2	1	25-61x	ZW448288	Tapping Screw #1 4x35(truss)		4
25-3	SP532315	Mech. Panel A	TW-6001	1	25-62x	ZW560902	Tapping Screw #1 4x50(truss), w/washer		4
25-4x	SP532326	Mech. Panel B (PRO)	TW-6001	1	25-63x	ZW488327	Tapping Screw #1 4x25(truss), w/washer		2
25-5	SE534194	Roel Table Escutcheon	TW-6002	2	25-64	SK534374	Pinch Roller Cap	TW-6019	2
25-6x	ZW323728	Screw, binding head 3x5		8	25-65	MP533744	Pinch Roller TW D=36	TW-1040	2
25-7	SE534205	RS Escutcheon	TW-6003	1	25-66	SK534418	Selector Knob B	TW-6023	2
25-8	SE534216	Tension Arm Escutcheon	TW-6004	2	25-67x	ZW434160	Set Screw, hexagon socket 3x3(cup)		2
25-9	SC534227	Head Cover Base	TW-6005	1	25-68	SZ535094	Decorative Washer	TW-2077	2
25-10	SE534238	DL Escutcheon	TW-6006	2	25-69	ZW408690	Screw, oval countersunk head 3x10		2
25-11	SE534240	Counter Lens	TW-6007	1	25-70	MZ533823	Mech. Side Plate C (Left)	TW-1047	1
25-12x	ZW413155	Screw, binding head 3x6		5	25-71	MZ533834	Mech. Side Plate D (Right)	TW-1047	1
25-13	SC534251	Head Cover	TW-6008	1	25-72	MZ533801	Reinforcement Angle	TW-1045	2
25-14x	SZ534317	Hinge Rod, w/angle	TW-6012	1	25-73	ZW416687	Screw, binding head 4x8		8
25-15x	MV269965	Steel Ball D=4		1	25-74x	MZ533812	Servo Shield	TW-1046	1
25-16x	ZG249107	Ball Retaining Spring	RD-632	1	25-75x	EJ419760	Nylon Clip HP-7N	2-7-41	1
25-17x	ZW383883	Set Screw 5x4(flat)		1	25-76x	EJ205986	Cramp Terminal 2-SD	32-1-8	15
25-18x	SZ534306	Hinge Angle C, w/sleeve	TW-6011	1	25-77	SP546895	Amp. Panel C	TW-5021	1
25-19x	ZW355511	Screw, binding head 3x6		2	25-78x	SP535465	Amp. Panel A (black)	TW-5021	1
25-20x	SZ534543	Cushion Rubber C D6x1t	TW-6039	2	25-79x	SP535476	Amp. Panel B (PRO)	TW-5021	1
25-21	SM534273	Name Plate GX-400D	TW-6009	1	25-80	SE535487	Push Button Escutcheon	TW-5023	2
25-22x	SM534262	Name Plate GX-400DPRO	TW-6009	1	25-81x	EZ535498	Escutcheon Holder	TW-5024	1
25-23	SZ382285	GX Symbol Plate	RD-A633	1	25-82	EM550721	VU Meter R-6.5-438B10-1 (yellow)	46-2-18	2
25-24x	SM540101	PRO Name Plate	TW-6202	1	25-83x	EM550710	VU Meter R-6.5-438B6-1 (blue)	46-2-17	2
CASE BLOCK					25-84	ZW301184	Screw, oval countersunk head 4x8		4
25-25	BC552060	Case Block Comp.	TW	1	25-85x	ZW203174	Screw, oval countersunk head 4x8(black)		4
25-26x	SZ382217	Fan Grill	RD-A 402	1	25-86	SZ534385	Panel Washer A	TW-6021	4
25-27x	ZW324448	Tapping Screw #1 3x10(truss)		3	25-87x	SZ534396	Panel Washer B (black)	TW-6021	4
25-28	SP535241	Ventilator A	TW-4002	1	25-88	SK534431	Amp. Knob A	TW-6025	6
25-29x	SZ535252	Ventilator Support	TW-4004	3	25-89x	ZW433001	Set Screw, hexagon socket 3x5(cup)		6
25-30x	ZW553994	Tapping Screw #1 3x8(round)		6	25-90	SK534442	Amp. Knob B	TW-6026	1
25-31	SZ275850	RD Square Foot	RD-402	2	25-91x	ZW434160	Set Screw, hexagon socket 3x3(cup)		2
25-32x	ZW479305	Screw, countersunk head 4x20		4	25-92	SK534418	Selector Knob B	TW-6023	1
ASSEMBLY BLOCK					25-93	SK534161	Push Knob	TW-5037	4
25-33	ML533777	Panel Support C (Right)	TW-1043	1	25-94	EZ436217	Collar, Jack	MC-5006	5
25-34	ML533788	Panel Support D (Left)	TW-1043	1	25-95	ES537873	Lever Switch JLO5, w/knob	25-4-14	4
25-35	ZW323728	Screw, binding head 3x5		8	25-96x	EF424811	Fuse ST-2 2.5A	39-1-26	1
25-36	ZW419736	Screw, binding head 4x6		4	25-97x	EF444183	Fuse 1.5A 250V	39-1-41	1
25-37	SB534071	Operation Button A	TW-2022	5	25-98x	SK534453	Amp. Knob A Rubber	TW-6027	6
25-38	SB534082	Operation Button B	TW-2022	1	25-99x	SK534464	Amp. Knob B Rubber	TW-6027	1
25-39	SE534093	Operate Lamp Escutcheon A (green)	TW-2023	2	25-100x	SK534475	Selector Knob Rubber	TW-6027	3
25-40	SE532517	Operate Lamp Escutcheon B (orange)	TW-2023	2					
25-41	SE532528	Operate Lamp Escutcheon C (red)	TW-2023	1					
25-42	SE532552	Operate Lamp Escutcheon D (black)	TW-2023	1					
25-43x	SB540022	Operation Button C (PRO)	TW-2203	3					
25-44x	SB540033	Operation Button D (Stop) (PRO)	TW-2203	1					
25-45x	SB540044	Operation Button E (Rec.) (PRO)	TW-2203	1					
25-46	ZW447840	Tapping Screw #2 3x8(BR)		6					
25-47	SZ534385	Panel Washer A	TW-6021	6					
25-48	ZW550631	Screw, oval countersunk head 4x10		6					
25-49x	ZW408835	Cap Nut M4(1 type #1)		2					
25-50x	SZ548695	Button Guide	TW-6047	1					
25-51	SP534341	Control Panel 1	TW-6015	1					
25-52	SE534352	Pilot Lamp Escutcheon	TW-6017	1					
25-53x	SP540055	Control Panel 2 (PRO)	TW-6201	1					
25-54x	SZ482681	Selector Lamp Mold B (PRO)	DF-6026	1					
25-55x	SE436151	Lamp Escutcheon (Rec.) (PRO)	DF-6025	1					
25-56	SZ534396	Panel Washer B	TW-6021	2					
25-57	ZW538470	Screw, oval countersunk head 4x10(black)		2					
25-58	ZW290250	U type Speed Nut M4 #1(large)	6-3-2	6					

When ordering parts, please describe Parts Number, Serial Number, and Model Number in detail.

INDEX

Parts No.	Ref. No. & Symbol No.	Parts No.	Ref. No. & Symbol No.	Parts No.	Ref. No. & Symbol No.	Parts No.	Ref. No. & Symbol No.	Parts No.	Ref. No. & Symbol No.
BA552262	17-1x	EC220994	11-C12	EC379765	13-C21	ED557447	11-D3,4,5	ER211465	10-R39,40
BA552273	10-1x	EC220994	12-C4	EC379765	13-C40	ED557447	11-D7to13	ER211465	10-R42
BA552284	11-1x	EC220994	12-C9	EC379765	22-C9, 10	ED557447	11-D15,16	ER211465	10-R44,45
BA552352	7-60	EC220994	12-C12	EC379765	23-C1, 2	ED557447	11-D20to39	ER211465	10-R58,59
BA552352	16-1x	EC220994	13-C14	EC379787	13-C35	ED557447	11-D42,43	ER211465	10-R62,63
BA552407	9-1x	EC220994	13-C16	EC389237	18-C6	EF424811	8-52	ER211465	10-R66,67
BA552431	21-1x	EC220994	13-C19	EC389237	18-C9	EF424811	25-96x	ER211465	10-R70,71
BA552442	19-1x	EC220994	13-C25	EC389474	12-C19	EF444183	25-97x	ER211465	10-R74,75
BA552453	20-1x	EC220994	13-C28	EC389474	22-C1, 2	EJ205986	8-51x	ER211465	11-R12
BA552464	22-1x	EC220994	21-C3, 4	EC392332	12-C17	EJ205986	25-76x	ER211465	11-R14
BA552475	22-2x	EC246137	14-C5	EC398878	14-C1 to 4	EJ222748	8-46	ER211465	11-R16
BA552486	23-1x	EC250604	9-C2	EC399565	12-C18	EJ233370	8-39	ER211465	11-R18,19
BA552497	14-1x	EC250604	9-C7, 8	EC406800	9-C10	EJ255093	4-26x	ER211465	11-R22
BA552508	15-1x	EC250683	13-C18	EC424708	22-C5, 6	EJ255115	24-12x	ER211465	11-R40
BA552510	13-1x	EC250683	22-C5, 6	EC425250	15-C1, 2	EJ255115	24-56x	ER211465	11-R42
BA552521	13-2x	EC250683	22-C7, 8	EC446242	15-C3	EJ292926	23-J2	ER211465	11-R44
BA552532	12-1x	EC250841	12-C14	EC450055	9-C16	EJ293062	24-48	ER211465	11-R46
BA552543	12-2x	EC250841	14-C9, 10	EC450066	13-C11	EJ293073	8-48x	ER211465	11-R48
BA552576	18-1x	EC250841	15-C7, 8	EC450527	12-C6	EJ293084	23-J1	ER211465	11-R50
BC552060	25-25	EC250885	11-C14	EC450527	12-C10	EJ310871	23-J4, 5	ER211465	11-R52
BF552330	4-1x	EC250885	11-C16	EC450527	21-C5	EJ310871	24-52x	ER211465	11-R55
BH552172	1-1x	EC251087	9-C21	EC454961	13-C26	EJ315101	24-70x	ER211465	13-R24
BH552183	1-2x	EC251155	9-C3	EC456041	10-C1,2,3	EJ347670	8-44x	ER211465	13-R35
BL552150	4-8x	EC251155	10-C18	EC456041	11-C5	EJ350447	13-3	ER211465	13-R39
BL552161	4-9x	EC251155	11-C11	EC456041	18-C1,2,3	EJ364915	8-45x	ER211465	13-R44
BL552363	5-1x	EC251190	9-C4	EC514708	13-C3	EJ368785	23-J6, 7	ER211465	13-R66
BL552374	5-2x	EC251190	10-C19	EC514708	13-C6	EJ368785	24-51x	ER211465	16-R4
BM552137	3-1	EC251190	11-C15	EC514708	13-C31	EJ368796	8-50x	ER211465	17-R6
BM552148	2-1	EC290520	12-C20	EC514708	13-C34	EJ368853	5-8	ER211465	17-R10
BP552227	8-1x	EC290520	13-C13	EC516868	13-C38	EJ368853	6-9	ER211465	21-R3
BP552238	8-3x	EC290520	13-C23	EC517138	13-C1, 2	EJ373623	24-49	ER211757	9-R34
BP552240	8-2x	EC290520	13-C36	EC517138	13-C29,30	EJ373634	8-49x	ER211757	9-R58
BP552251	8-4x	EC316091	17-C2	EC537884	8-53	EJ373691	24-50x	ER211757	9-R61
BR552317	3-6x	EC320051	9-C11,12	EC538018	8-11	EJ378944	8-15	ER211757	12-R12
BR552328	3-5x	EC324538	10-C11	EC538211	9-C6	EJ419760	25-75x	ER211757	12-R25,26
BT247746	12-T1	EC329883	13-C20	EC538244	9-C13	EJ437310	24-27	ER211757	12-R29,30
BT538020	8-12	EC329883	22-C9, 10	EC538244	9-C15	EJ437321	24-34	ER211757	13-R13
BZ552071	25-1x	EC331705	10-C12	EC538435	12-C15	EJ457637	24-4x	ER211858	12-R8
BZ552082	25-2x	EC331705	11-C3	EC557155	9-C20	EJ457661	24-3x	ER211858	13-R19
BZ552295	6-1x	EC335452	14-C6, 7	EC557166	12-C1	EJ482793	23-J3	ER212016	9-R63
BZ552306	6-2x	EC335452	15-C4, 5	ED219464	13-D1	EJ482793	24-53x	ER212264	9-R15
BZ552341	5-24x	EC336104	9-C17	ED219464	13-D4	EL390576	6-6	ER212264	9-R17
BZ552385	4-39x	EC336115	9-C19	ED224526	9-D2,3,4	EL390576	6-39x	ER212264	9-R19,20
BZ552396	4-28x	EC336115	17-C5	ED224526	9-D6	EL390576	7-61	ER212264	9-R50
BZ552554	24-1	EC336126	12-C8	ED224526	15-D1	EL390576	16-IND7,8	ER212264	9-R59
BZ552565	24-2x	EC336126	13-C12	ED224526	17-D4, 5	EL443520	6-26x	ER212264	11-R60
BZ556694	2-12	EC336126	13-C17	ED224526	19-D1	EM550710	24-83x	ER212264	13-R4
EA222096	1-34x	EC336126	14-C8	ED224550	4-21x	EM550710	25-83x	ER212264	13-R8
EA382713	1-33x	EC336126	15-C6	ED224550	7-21x	EM550721	24-82	ER212264	13-R56
EA496258	12-3	EC336194	12-C16	ED224550	7-48x	EM550721	25-82	ER212264	13-R60
EA534036	8-31	EC336216	13-C10	ED224550	17-D1, 2	EO346230	12-L1	ER212477	9-R3
EA534137	24-26	EC336521	13-C24	ED224550	24-63x	EO383365	14-L1	ER212477	9-R10
EA534148	14-2	EC337500	13-C20	ED224572	8-6	EO383365	15-L1	ER212477	9-R29
EA534622	6-5	EC337500	22-C7, 8	ED350471	9-D1	EO443722	13-L1	ER212477	9-R52
EA535048	5-40	EC350616	12-C20	ED384096	21-D1, 2	EO455883	13-L3	ER212477	9-R55
EA549472	6-38x	EC350638	18-C5	ED491130	13-D3	EO488430	19-L1	ER212477	12-R3
EC220105	12-C3	EC350638	18-C7, 8	ED494583	10-D5	EO538391	13-L2	ER212477	12-R14
EC220151	9-C9	EC350638	18-C10	ED494583	10-D8, 9	EP344136	9-RL1	ER212477	12-R28
EC220151	12-C5	EC350684	10-C13	ED494583	10-D14	EP344136	10-RL1to5	ER212477	13-R15
EC220151	13-C5	EC350684	11-C4	ED494583	10-D16	EP344136	11-RL1to4	ER212477	13-R29
EC220151	13-C7, 8	EC350706	13-C9	ED494583	10-D23to26	EP344136	17-RL1,2	ER212681	9-R2
EC220151	13-C33	EC350706	13-C15	ED494583	11-D1, 2	EP383321	15-RL1	ER212681	9-R45
EC220364	13-C4	EC350717	13-C39	ED494583	11-D6	EP383321	19-RL1	ER212681	17-R7
EC220364	13-C32	EC350875	12-C19	ED494583	11-D14	EP537895	7-45	ER212883	9-R18
EC220432	10-C7, 8	EC350875	13-C21	ED494583	11-D17,18,19	EP537906	7-18	ER212883	9-R33
EC220432	10-C14to17	EC350875	17-C4	ED515790	13-D2	EP538457	4-20	ER212883	10-R10,11
EC220432	11-C2	EC350875	22-C1, 2	ED515790	18-D1,2,3	EP538468	24-62	ER212883	10-R14to18
EC220432	11-C8,9,10	EC350875	22-C3, 4	ED538042	9-D5	ER211320	9-R5	ER212883	10-R20,21,22
EC220432	12-C11	EC350875	22-C11, 12	ED538042	17-D3	ER211320	9-R25	ER212883	10-R32,33
EC220590	12-C2	EC350987	17-C6, 7	ED538165	9-D7	ER211320	9-R30	ER212883	10-R38
EC220590	12-C7	EC362125	9-C5	ED538176	9-D8	ER211320	12-R21	ER212883	10-R46 to 55
EC220590	12-C13	EC362125	9-C18	ED555895	11-D44	ER211320	12-R31	ER212883	11-R1to 5
EC220612	10-C9	EC368695	8-9	ED557190	8-8	ER211465	9-R1	ER212883	11-R7,8,9
EC220612	21-C1, 2	EC372148	17-C1	ED557201	9-TH1	ER211465	9-R27	ER212883	11-R26
EC220994	9-C1	EC372148	17-C3	ED557447	10-D1 to 4	ER211465	9-R47	ER212883	11-R28
EC220994	9-C14	EC379170	13-C22	ED557447	10-D6, 7	ER211465	9-R53,54	ER212883	11-R30to35
EC220994	10-C4,5,6	EC379170	13-C27	ED557447	10-D10to13	ER211465	10-R7	ER212883	11-R37,38
EC220994	10-C10	EC379170	13-C37	ED557447	10-D15	ER211465	10-R25,26	ER212883	11-R56
EC220994	11-C1	EC379721	13-C38	ED557447	10-D17to22	ER211465	10-R29,30	ER212883	11-R58
EC220994	11-C6, 7	EC379721	22-C3, 4	ED557447	10-D27to63	ER211465	10-R35	ER212883	11-R62

INDEX

Parts No.	Ref. No. & Symbol No.	Parts No.	Ref. No. & Symbol No.	Parts No.	Ref. No. & Symbol No.	Parts No.	Ref. No. & Symbol No.	Parts No.	Ref. No. & Symbol No.
ER212883	12-R11	ER336442	13-R70	ER376424	6-36	ET398788	12-TR4, 5	EZ432088	1-32x
ER212883	13-R25	ER336442	17-R9	ER376424	10-CR1to15	ET398788	13-TR6	EZ432088	1-35x
ER212883	13-R69	ER343078	9-R4	ER376424	11-CR1to10	ET399881	9-TR14	EZ436217	24-32x
ER213030	9-R24	ER343078	13-R42	ER376435	9-CR1, 2	ET418871	17-TR1	EZ436217	25-94
ER213030	9-R26	ER345712	18-R1	ER380711	9-R51	ET430907	10-TR18	EZ531854	24-39
ER213030	9-R43	ER345756	24-9x	ER380711	13-R49	ET430907	11-TR13	EZ532293	24-14
ER213030	10-R27, 28	ER346544	9-R31	ER380913	13-R45	ET444003	13-TR2	EZ532304	24-42
ER213030	10-R31	ER346601	9-R23	ER419040	9-R65	ET444003	13-TR4	EZ534003	8-43x
ER213030	10-R41	ER346601	9-R49	ER424855	12-R5	ET444003	13-TR12	EZ534014	10-2x
ER213030	10-R43	ER346601	9-R60	ER426857	12-R13	ET453486	10-TR1to 7	EZ534014	11-2x
ER213030	10-R56,57	ER346601	10-R79	ER426857	13-R47,48	ET453486	10-TR10	EZ534025	8-27
ER213030	10-R60,61	ER346601	11-R54	ER427083	12-R4	ET453486	10-TR13	EZ534172	18-3
ER213030	10-R64,65	ER346601	12-R1	ER427083	12-R10	ET453486	10-TR15,16,17	EZ534870	7-63
ER213030	10-R68,69	ER346601	12-R15,16	ER427241	9-R57	ET453486	10-TR19to23	EZ534870	16-3
ER213030	10-R72,73	ER346601	13-R2	ER429794	13-R7	ET453486	11-TR1,2,3	EZ534892	7-62
ER213030	11-R13	ER346601	13-R41	ER429794	13-R12	ET453486	11-TR5 to 8	EZ534892	16-2x
ER213030	11-R15	ER346601	13-R54	ER429794	13-R59	ET453486	11-TR10,11,12	EZ535274	24-45
ER213030	11-R17	ER346601	13-R65	ER429794	13-R64	ET453486	11-TR14,15,16	EZ535285	24-73
ER213030	11-R39	ER346994	12-R20	ER429996	6-35x	ET453486	11-TR18, 19	EZ535296	24-74
ER213030	11-R41	ER346994	12-R34	ER429996	21-R1, 2	ET459810	12-TR1	EZ535307	24-40
ER213030	11-R43	ER346994	13-R67	ER430007	9-R42	ET459810	12-TR3	EZ535318	24-36
ER213030	11-R45	ER347073	18-R3, 4	ER430108	9-R8	ET460912	12-TR2	EZ535331	18-2
ER213030	11-R47	ER349907	9-R7	ER430200	14-R10	ET460912	12-TR7	EZ535342	24-71
ER213030	11-R49	ER349907	9-R16	ER433877	22-R3, 4	ET495437	13-TR1	EZ535353	24-72x
ER213030	11-R51	ER349907	10-R37	ER450011	12-R18	ET495437	13-TR3	EZ535364	24-57
ER213030	11-R53	ER349907	15-R4	ER450011	13-R18	ET495437	13-TR5	EZ535375	24-65
ER213030	12-R19	ER349942	12-R9	ER450011	13-R28	ET395437	13-TR11	EZ535410	24-15
ER213030	13-R38	ER349942	13-R5	ER450011	13-R40	ET511920	10-TR8, 9	EZ535421	24-25
ER213030	16-R3	ER349942	13-R11	ER515125	10-R19	ET511920	10-TR14	EZ535432	24-21
ER213030	21-R4	ER349942	13-R51	ER538086	17-R1	ET511920	10-TR24	EZ535498	24-79x
ER213096	12-R32	ER349942	13-R57	ER538086	17-R4	ET511920	11-TR4	EZ535498	25-81x
ER213096	17-R11	ER349942	13-R63	ER538097	17-R8	ET511920	11-TR17	EZ541451	24-41
ER213120	22-R1, 2	ER352045	9-R28	ER538301	14-R5, 6	ET511920	17-TR2	HE552914	1-19x
ER213647	23-R3, 4	ER352045	13-R6	ER538301	15-R1	ET520277	12-TR6	HP552194	1-15
ER213647	24-10x	ER352045	13-R10	ER538301	23-R5	ET520277	13-TR8	HP552205	1-17x
ER214290	23-R1, 2	ER352045	13-R21	ER538345	14-R7	ET520288	14-TR1,2,3	HR552216	1-18x
ER304290	9-R11	ER352045	13-R58	ER538345	15-R2	ET520288	15-TR1,2,3	HR556582	1-16
ER304402	9-R37	ER352045	13-R62	ER538413	12-R2	ET537300	10-TR11,12	HZ532664	1-3
ER304402	9-R62	ER357456	9-R9	ER538424	12-R6	ET538007	8-22	HZ532675	1-4
ER304402	13-R22,23	ER357456	9-R32	ER538424	13-R16	ET538110	10-TR25,26,27	HZ532686	1-13
ER306360	13-R26	ER357456	9-R44	ER539010	17-R3	ET538110	11-TR9	HZ532697	1-11
ER306360	13-R34	ER357456	9-R46	ER550596	17-R13	ET538110	11-TR20	HZ532708	1-10
ER306843	9-R40	ER357456	9-R48	ER550607	12-R36	ET538143	9-TR10,11	HZ532710	1-12
ER306843	13-R37	ER357456	10-R23,24	ER551878	17-R2	ET538154	9-TR4	HZ532721	1-14
ER306843	13-R52	ER357456	10-R34	ER551924	10-R80	ET538154	9-TR9	HZ532732	1-9
ER306843	17-R5	ER357456	10-R76,77,78	ER551924	11-R63	ET538154	9-TR13	HZ532743	1-7
ER306887	9-R22	ER357456	11-R10,11	ER554556	17-R14	ET538378	13-TR7	HZ532754	1-8
ER306887	13-R17	ER357456	11-R29	ER554681	9-R64	ET550798	13-TR10	HZ532765	1-6
ER306887	13-R46	ER357456	11-R36	ER560744	6-30	EV484863	9-VR1	HZ532776	1-5
ER315944	15-R5	ER357456	12-R17	ER561611	13-R3	EV496271	14-VR1, 2	HZ533597	1-20x
ER324641	10-R3, 4	ER357456	12-R23,24	ER561611	13-R55	EV496271	15-VR1	HZ533608	1-21x
ER324641	11-R6	ER357456	12-R27	ES250064	5-5	EV497687	10-VR1	HZ540573	1-23x
ER324641	18-R2	ER357456	12-R33	ES250064	7-14	EV497687	12-VR1, 2	MB314987	7-30
ER324641	24-29x	ER357456	13-R32, 33	ES250075	6-14	EV497698	13-VR3, 4	MB533057	3-23
ER324685	14-R9	ER357456	13-R50	ES479485	8-17	EV497700	13-VR5	MB533057	7-39
ER324685	24-8x	ER357456	15-R3	ES537873	6-28	EV498060	12-VR3	MB533068	3-24x
ER324808	14-R1 to 4	ER357456	21-R5	ES537873	7-54	EV498071	17-VR1	MB533068	7-52
ER329264	14-R8	ER357491	13-R9	ES537873	25-95	EV513562	10-VR2	MB533070	4-63
ER329308	24-19x	ER357491	13-R61	ES538132	6-31	EV513562	11-VR1	MC399521	7-51
ER336442	9-R6	ER357535	10-R6	ES538255	23-SW2	EV538187	9-VR2	MH532912	7-2
ER336442	9-R12,13,14	ER357535	11-R21	ES538266	23-SW3	EV538198	9-VR3	MH532923	7-4
ER336442	9-R21	ER357535	13-R20	ES538277	23-SW1	EV538200	9-VR4	MH532934	7-5
ER336442	9-R35	ER357535	21-R6	ES538312	20-SW1	EV538380	13-VR1, 2	MH532945	7-6
ER336442	9-R36	ER357570	10-R9	ES538312	21-SW1	EV538380	13-VR2	MH532967	4-57
ER336442	9-R38, 39	ER357570	11-R24	ES538323	19-SW1	EV538402	12-VR4, 5	MH532978	7-9
ER336442	9-R41	ER357570	13-R14	ES538334	22-SW1	EV538481	24-26	MH534183	23-2
ER336442	9-R56	ER361528	12-R1	ES538446	18-SW1	EV538492	24-17	MH534183	24-54x
ER336442	10-R1, 2	ER361528	13-R68	ES539177	24-5	EV538503	24-18	MI534734	4-2
ER336442	10-R5	ER361563	12-R7	ES551935	6-32x	EV538514	24-20	ML237418	7-22
ER336442	10-R12,13	ER361563	13-R1	ES564748	24-11x	EW524845	8-36x	ML533035	7-13
ER336442	10-R36	ER361563	13-R53	ET234854	13-TR9	EW540112	8-34x	ML533046	7-53
ER336442	11-R20	ER362441	17-R12	ET334383	9-TR1	EZ225180	24-30x	ML533081	7-44
ER336442	11-R25	ER362485	10-R8	ET379462	9-TR2, 3	EZ246936	8-38x	ML533092	7-40
ER336442	11-R27	ER362485	11-R23	ET379462	9-TR5 to 8	EZ315448	8-35x	ML533103	7-41
ER336442	11-R57	ER362485	13-R27	ET379462	9-TR12	EZ328320	24-69	ML533114	7-42
ER336442	11-R59	ER363644	13-R43	ET379462	9-TR15	EZ382263	8-37	ML533610	6-37x
ER336442	11-R61	ER364948	24-7x	ET379462	16-TR3	EZ397124	8-20	ML533621	7-47
ER336442	12-R22	ER364948	24-28x	ET380834	21-TR1,2,3	EZ397304	8-16	ML533632	7-28
ER336442	13-R30,31	ER364961	12-R35	ET393557	8-29	EZ409836	8-30x	ML533643	7-35
ER336442	13-R36	ER364994	21-R7	ET398711	9-TR16,17	EZ428117	6-25	ML533654	7-23

INDEX

Parts No.	Ref. No. & Symbol No.	Parts No.	Ref. No. & Symbol No.	Parts No.	Ref. No. & Symbol No.	Parts No.	Ref. No. & Symbol No.	Parts No.	Ref. No. & Symbol No.
ML533665	7-27	MZ534791	5-26	SP546895	24-75	ZW323728	10-3	ZW447805	24-46x
ML533687	7-36	MZ534802	5-29	SP546895	25-77	ZW323728	11-3	ZW447840	6-51
ML533777	7-66	MZ534813	5-33	SZ275850	25-31	ZW323728	24-47x	ZW447840	25-46
ML533777	25-33	MZ534835	5-35	SZ377190	25-59x	ZW323728	25-6x	ZW448288	25-61x
ML533788	7-67x	MZ534857	5-36	SZ382217	25-26x	ZW323728	25-35	ZW455275	24-33x
ML533788	25-34	MZ534868	5-31	SZ382285	25-23	ZW324448	25-27x	ZW459033	2-11
ML533845	4-11	MZ534958	5-11	SZ450720	2-15	ZW327835	8-19x	ZW459033	4-68
ML533856	4-10	MZ535072	5-43	SZ482681	25-54x	ZW330412	7-56x	ZW459167	2-2
ML533878	4-13	MZ535083	5-41	SZ534306	25-18x	ZW330412	4-65	ZW459167	3-3
ML533924	4-22	MZ535116	4-29	SZ534317	25-14x	ZW330423	4-66x	ZW462194	24-93x
ML533924	7-19	MZ535116	4-40	SZ534385	24-86x	ZW330423	7-57x	ZW462205	4-62
ML534633	6-27	MZ535138	4-31	SZ534385	25-47	ZW330445	4-67x	ZW477876	1-22
ML534903	5-4	MZ535140	4-32	SZ534385	25-86	ZW330445	7-58x	ZW479305	25-32x
ML534914	5-3	MZ535206	4-35	SZ534396	24-87x	ZW334653	2-14x	ZW488327	25-63x
ML534960	5-17	MZ535217	4-37	SZ534396	25-56	ZW339502	24-80x	ZW494741	2-4
ML534971	5-16	MZ535217	4-44	SZ534396	25-87x	ZW355511	25-19x	ZW516993	1-36
ML535037	5-38	MZ535228	4-30	SZ534543	25-20x	ZW371856	6-29	ZW532462	2-9
ML543025	7-29	MZ535228	4-41	SZ535094	5-46	ZW371856	7-55	ZW533766	4-55
MP533744	4-53	MZ540000	6-20x	SZ535094	25-68	ZW371856	8-18	ZW533891	4-15
MP533744	25-65	MZ540011	6-16x	SZ535252	25-29x	ZW371856	24-37x	ZW533902	4-16
MR532440	2-10	MZ802980	4-18	SZ548695	25-50x	ZW372025	8-40	ZW533913	4-24
MR533002	7-38	MZ810191	5-7	VM360090	4-7	ZW382162	7-34	ZW533913	7-24
MR534690	3-20	MZ810191	7-43	ZG243257	4-17	ZW383883	25-17x	ZW533913	24-64
MS342000	3-9	SB534071	6-42	ZG249107	25-16x	ZW384131	2-3	ZW534982	5-14
MS532956	4-46	SB534071	25-37	ZG317496	3-19	ZW384131	3-4	ZW535015	5-12
MS532956	7-7	SB534082	6-43	ZG364656	1-29	ZW384131	5-32	ZW535320	24-43
MS532980	7-12	SB534082	25-38	ZG382757	1-30x	ZW391476	2-16	ZW535397	24-59x
MS533147	5-39	SB540022	6-48x	ZG466312	1-31	ZW394086	24-67x	ZW536490	1-25
MS533867	4-12	SB540022	25-43x	ZG533700	4-49	ZW396000	1-26	ZW537006	1-24
MS534600	6-11	SB540033	6-49x	ZG533711	4-48	ZW408690	5-47	ZW537930	3-2
MS534723	4-3	SB540033	25-44x	ZG533733	7-49	ZW408690	25-69	ZW537941	2-6
MS534778	5-25	SB540044	6-50x	ZG534824	5-28	ZW408835	25-49x	ZW537974	2-13
MS534936	5-9	SB540044	25-45x	ZG534846	5-34	ZW413155	4-23x	ZW538470	25-57
MS534947	5-10	SC534227	25-9	ZG535026	5-13	ZW413155	5-19	ZW550631	25-48
MS535050	5-44	SC534251	25-13	ZG535105	5-20	ZW413155	7-20x	ZW550642	5-22
MS535061	5-42	SE436151	25-55x	ZG535151	4-33	ZW413155	25-12x	ZW550697	24-60x
MS535173	4-43	SE532517	6-45	ZG535162	4-42	ZW413201	4-59	ZW553972	24-81x
MS535184	4-36	SE532517	25-40	ZG535443	24-61	ZW413223	7-50	ZW553983	24-58
MS535195	4-34	SE532528	6-46	ZG535454	24-23	ZW413278	4-47x	ZW553994	25-30x
MT436860	3-18	SE532528	25-41	ZG540090	7-33	ZW413278	7-8x	ZW554005	5-15x
MT473433	3-13	SE532552	6-47	ZG540584	1-28	ZW413741	8-7	ZW560215	4-51x
MT473444	3-14x	SE532552	25-42	ZG540617	3-10	ZW413741	8-32x	ZW560226	4-52x
MT534666	3-7	SE534093	6-44	ZW201150	8-21	ZW413741	23-3x	ZW560902	25-62x
MT534677	3-8	SE534093	25-39	ZW201150	8-28	ZW413741	24-55x	ZW561486	7-26
MT534688	3-12	SE534194	25-5	ZW203084	4-38	ZW413785	7-16	ZW561655	24-31
MV269965	4-60	SE534205	25-7	ZW203084	4-45	ZW416687	4-58x		
MV269965	25-25x	SE534216	25-8	ZW203174	24-84x	ZW416687	4-64		
MZ250413	7-15	SE534238	25-10	ZW203174	25-85x	ZW416687	7-10x		
MZ302400	8-47	SE534240	25-11	ZW243516	4-50	ZW416687	8-13		
MZ314998	7-31	SE534352	25-52	ZW257477	7-46	ZW416687	25-73		
MZ453767	4-61	SE535487	24-78x	ZW259773	7-37	ZW416698	1-37		
MZ532271	7-1	SE535487	25-80	ZW260245	4-6	ZW416698	4-19		
MZ532383	2-5	SK245182	24-6x	ZW270088	3-11	ZW417148	5-6		
MZ532451	2-7	SK534161	24-38	ZW270088	4-25	ZW417148	5-45		
MZ532563	6-18	SK534161	25-93	ZW270088	5-23	ZW417194	7-64		
MZ532574	6-13	SK534374	4-56	ZW270088	6-12	ZW417194	8-23		
MZ532574	6-19	SK534374	25-64	ZW270088	7-25	ZW417194	16-4		
MZ532585	6-15	SK534418	24-92	ZW270088	24-66x	ZW417227	6-40x		
MZ533676	5-21	SK534418	25-66	ZW272722	24-35x	ZW419646	25-60x		
MZ533698	7-59	SK534418	25-92	ZW273745	8-25x	ZW419736	25-36		
MZ533801	25-72	SK534431	24-88	ZW273756	6-34x	ZW419782	24-13x		
MZ533812	25-74x	SK534431	25-88	ZW273756	7-3x	ZW424056	2-8		
MZ533823	25-70	SK534442	24-90	ZW273756	8-26x	ZW425002	5-18		
MZ533834	25-71	SK534442	25-90	ZW273756	24-44x	ZW425103	3-17		
MZ533880	4-14	SK534453	25-98x	ZW273778	3-15x	ZW425981	3-16x		
MZ533935	8-5	SK534464	25-99x	ZW273778	6-33x	ZW430402	4-54		
MZ533946	8-41x	SK534475	25-100x	ZW273778	8-24x	ZW430863	1-27		
MZ533957	8-42	SK534745	4-5	ZW273914	7-11x	ZW433001	24-89x		
MZ533968	8-14	SM534262	25-22x	ZW290250	25-58	ZW433001	25-89x		
MZ534047	6-3	SM534273	25-21	ZW290283	7-32	ZW433315	3-21		
MZ534058	6-21	SM540101	25-24x	ZW290283	24-68	ZW434160	24-22x		
MZ534060	6-22	SP532315	25-3	ZW301184	24-85x	ZW434160	24-91x		
MZ534587	6-10	SP532326	25-4x	ZW301184	25-84	ZW434160	25-67x		
MZ534598	6-17	SP534341	25-51	ZW323728	4-27x	ZW434160	25-91x		
MZ534611	6-4	SP535241	25-28	ZW323728	4-69	ZW435273	3-22		
MZ534644	6-23	SP535465	24-76x	ZW323728	5-37	ZW447772	6-7		
MZ534655	6-24	SP535465	25-78x	ZW323728	6-8	ZW447772	6-41x		
MZ534701	4-4	SP535476	24-77x	ZW323728	7-17	ZW447772	8-10		
MZ534756	5-30	SP535476	25-79x	ZW323728	7-65	ZW447772	18-4		
MZ534767	5-27	SP540055	25-53x	ZW323728	8-33x	ZW447772	24-24		

SECTION 3

CONNECTION DIAGRAM

1. GX-400D AMPLIFIER BLOCK
2. GX-400D MECHANISM BLOCK
3. GX-400D·PRO AMPLIFIER BLOCK
4. GX-400D·PRO MECHANISM BLOCK

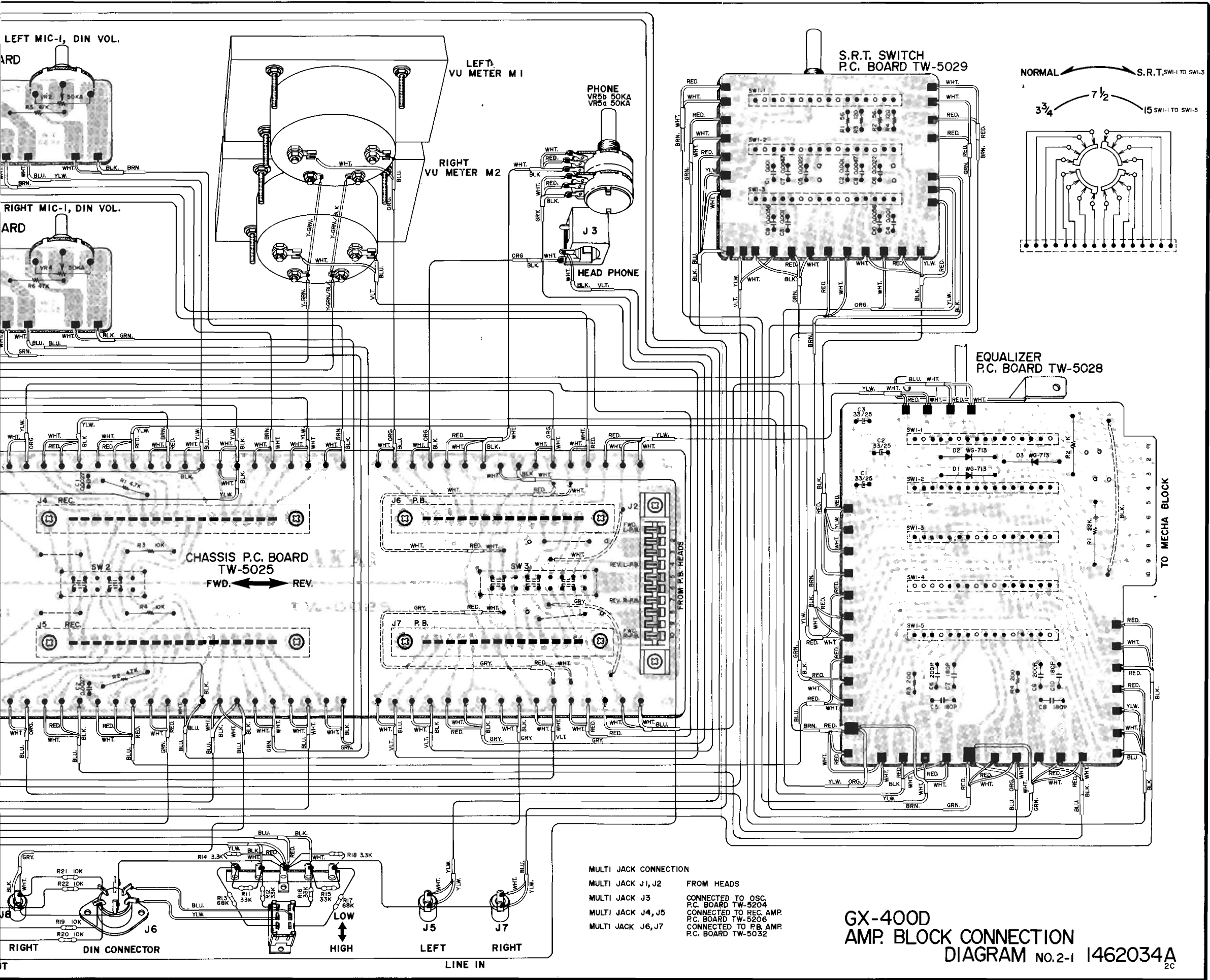

MULTI JACK CONNECTION
 MULTI JACK J1, J2 FROM HEADS
 MULTI JACK J3 CONNECTED TO OSC. P.C. BOARD TW-5204
 MULTI JACK J4, J5 CONNECTED TO REC. AMP. P.C. BOARD TW-5206
 MULTI JACK J6, J7 CONNECTED TO P.B. AMP. P.C. BOARD TW-5032

GX-400D
 AMP. BLOCK CONNECTION
 DIAGRAM NO.2-1 1462034A
 2C

SERVO CONTROL P.C. BOARD TW-1049

TR1	C1	210V
TR2	C2	240V
TR3	C3	21.6V
TR4	C4	7.8V
TR5	C5	6.2V
TR6	C6	20.2V
TR7	C7	20.8V
TR8	C8	8.3V
TR9	C9	1.6V
TR10	C10	0.4V
TR11	C11	15.1V
TR12	C12	1.1V
TR13	C13	2.3V
TR14	C14	3.0V
TR15	C15	1.8V
TR16	C16	2.2V
TR17	C17	3.9V
TR18	C18	1.8V
TR19	C19	2.5V
TR20	C20	1.6V
TR21	C21	1.9V
TR22	C22	1.5V
TR23	C23	2.2V
TR24	C24	3.9V
TR25	C25	0.9V
TR26	C26	1.8V
TR27	C27	3.9V
TR28	C28	1.8V
TR29	C29	1.8V
TR30	C30	0.4V
TR31	C31	0.4V
TR32	C32	2.1V
TR33	C33	0.6V
TR34	C34	1.8V
TR35	C35	1.3V

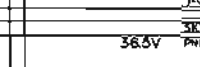
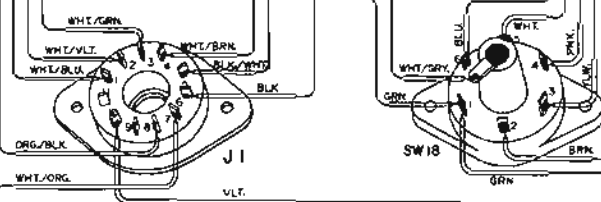
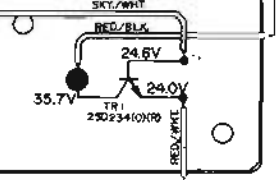
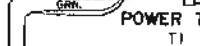
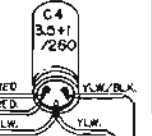
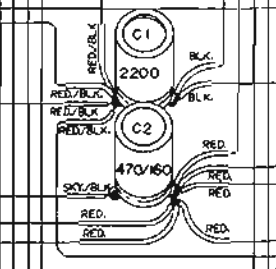
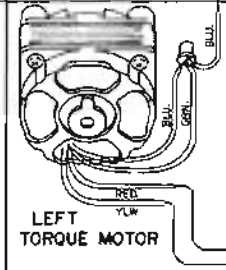
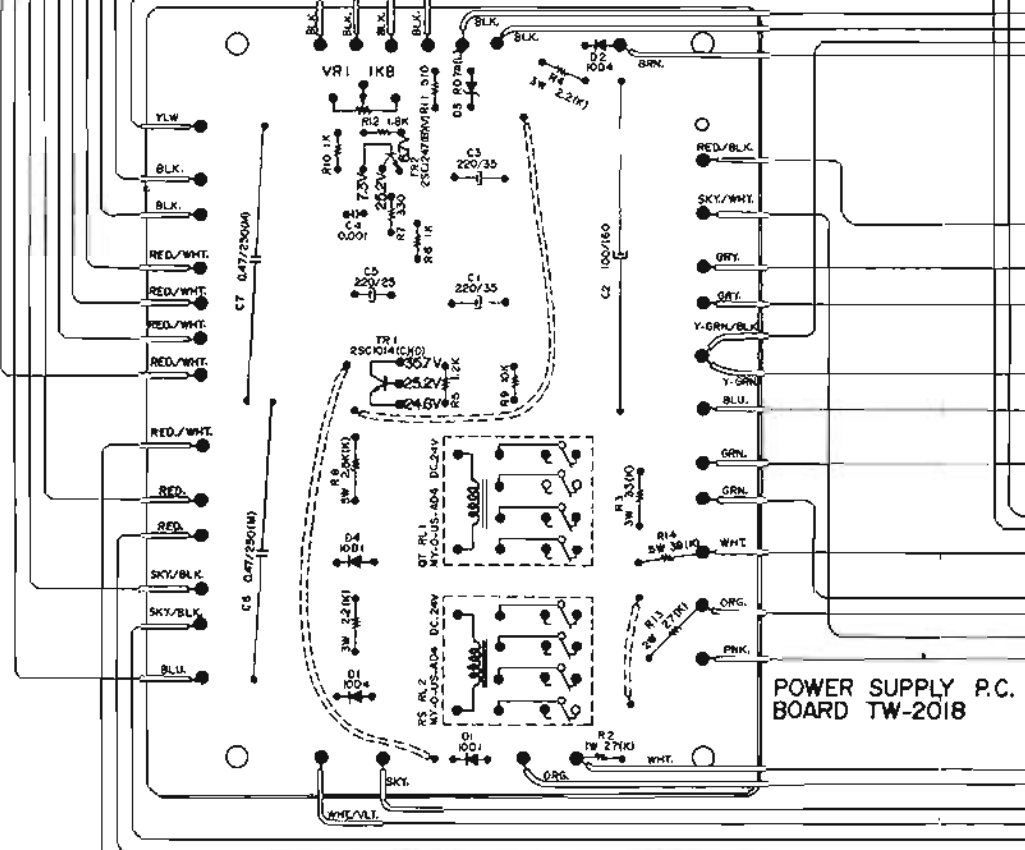
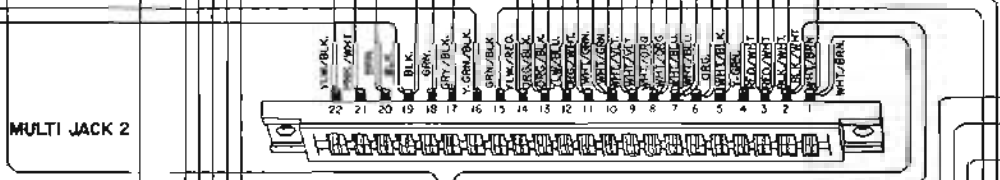
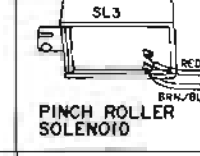
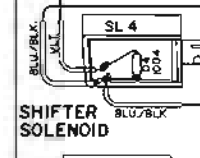
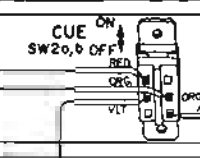
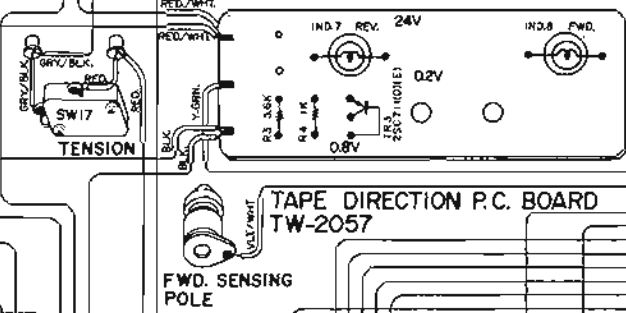
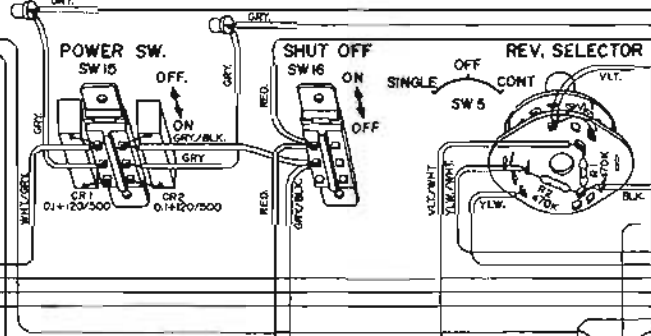
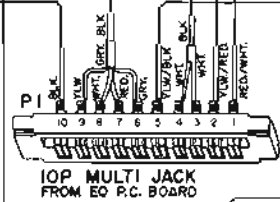
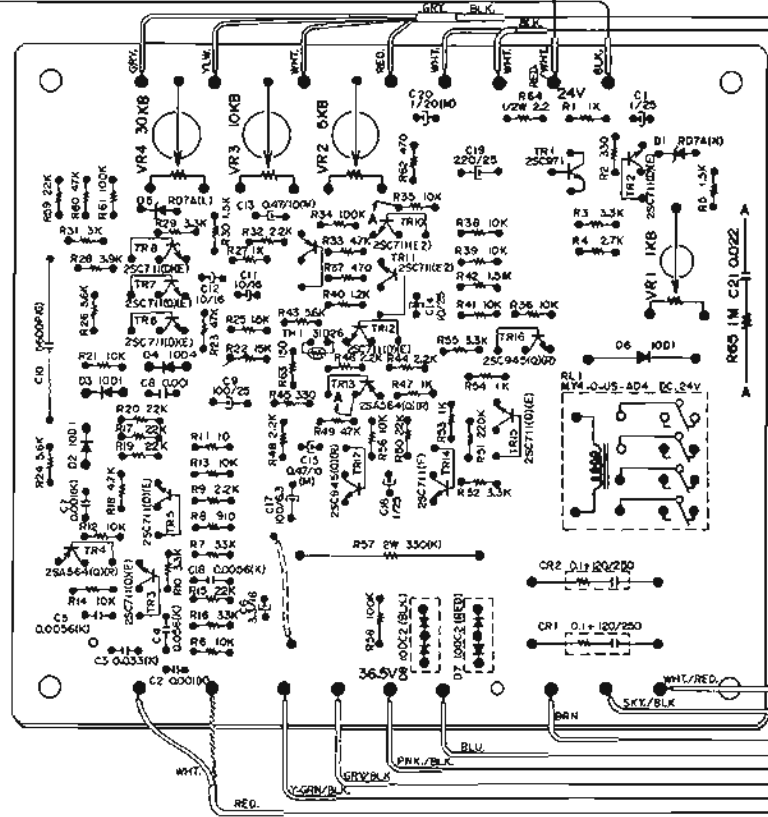

REMO-CON JACK

VOLTAGE SELECTOR & FUSE POST

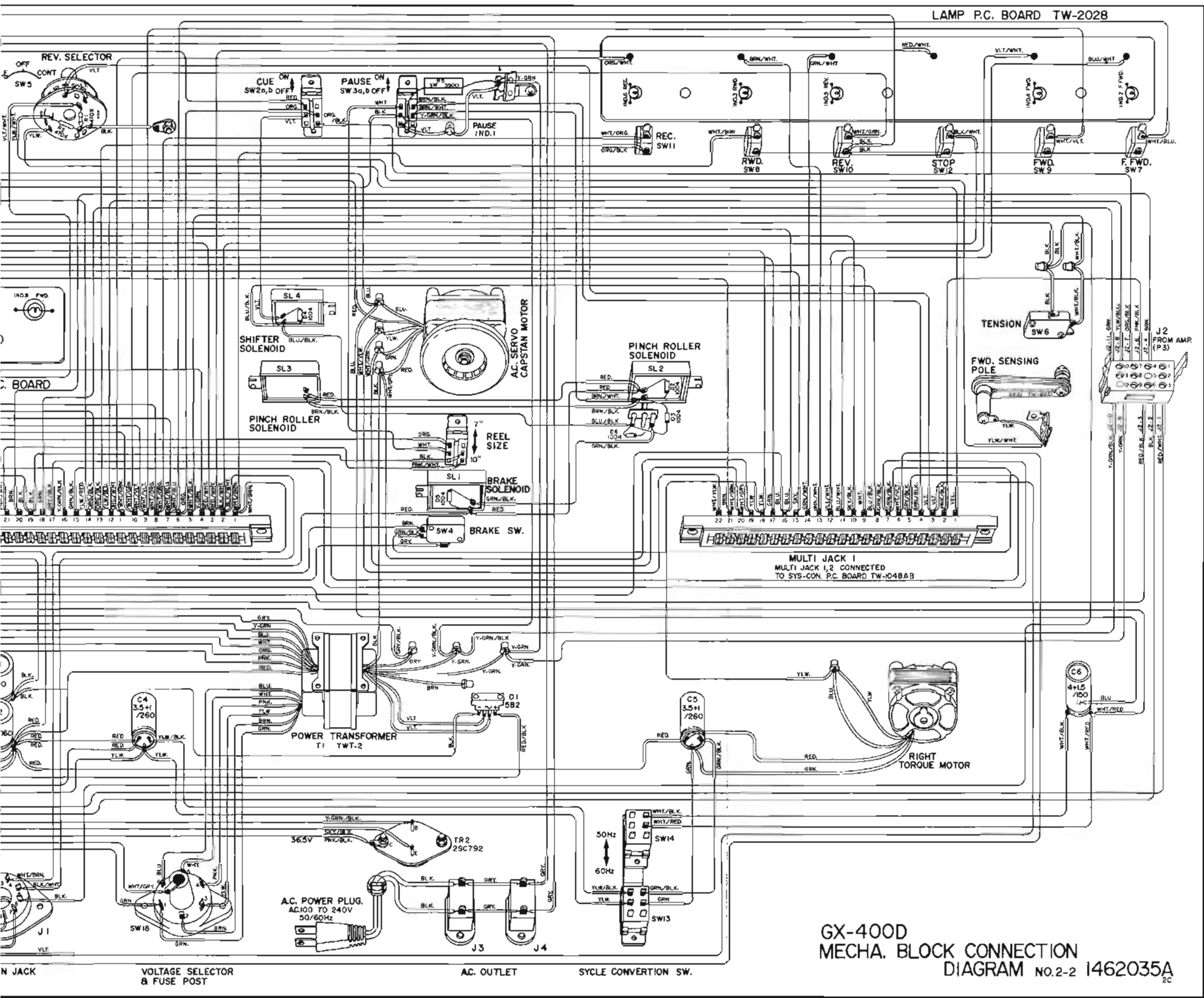

GX-400D MECHA. BLOCK CONNECTION DIAGRAM NO.2-2 1462035A

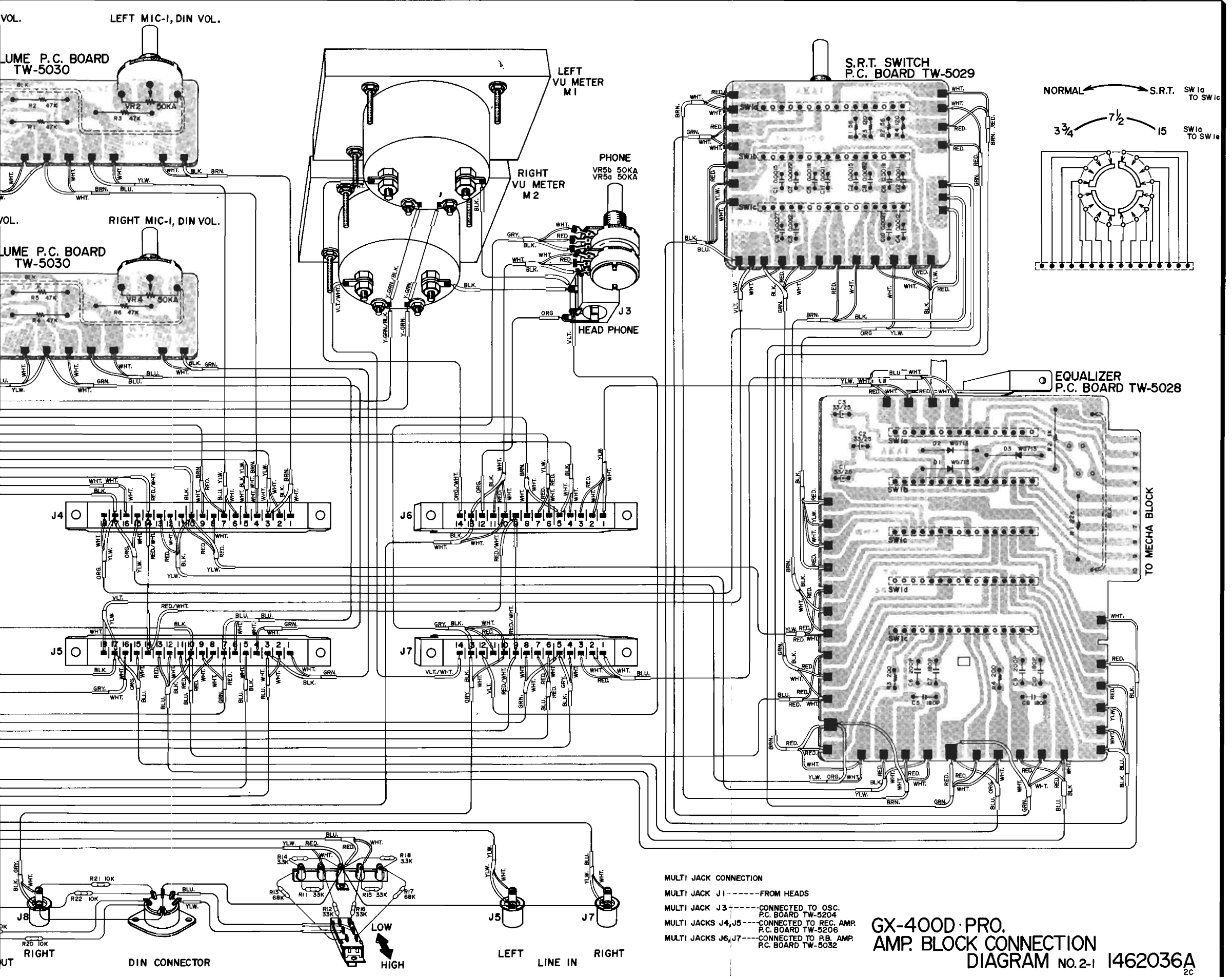

MULTI JACK CONNECTION
 MULTI JACK J1 -----FROM HEADS
 MULTI JACK J3 -----CONNECTED TO OSC.
 P.C. BOARD TW-5204
 MULTI JACKS J4, J5 -----CONNECTED TO REC. AMP.
 P.C. BOARD TW-5206
 MULTI JACKS J6, J7 -----CONNECTED TO P.B. AMP.
 P.C. BOARD TW-5032

GX-400 · PRO.
AMP. BLOCK CONNECTION
DIAGRAM NO. 2-1 1462036A
 2C

TR1	F	21.0V
	C	24.0V
	B	21.6V
	C	7.2V
	B	21.6V
	C	7.8V
	B	6.2V
	C	20.2V
	B	6.6V
	C	20.8V
	B	8.3V
TR4		
TR5	F	6.6V
	C	0.4V
	B	7.0V
	C	13.1V
	B	3.2V
	C	1.1V
	B	3.0V
	C	7.7V
	B	1.8V
	C	18.9V
	B	5.1V
	C	14.7V
	B	3.0V
	C	9.3V
	B	1.6V
	C	2.3V
	B	2.6V
	C	1.1V
	B	3.9V
	C	2.2V
	B	3.9V
	C	0.9V
	B	19.1V
	C	3.9V
	B	18.4V
	C	0.9V
	B	19.1V
	C	3.9V
	B	18.4V
TR14	F	0.3V
	C	0.4V
	B	0
	C	21.0V
	B	0.6V
	C	21.0V
	B	0.3V
TR16	F	21.0V
	C	0
	B	19.9V
	C	1.3V

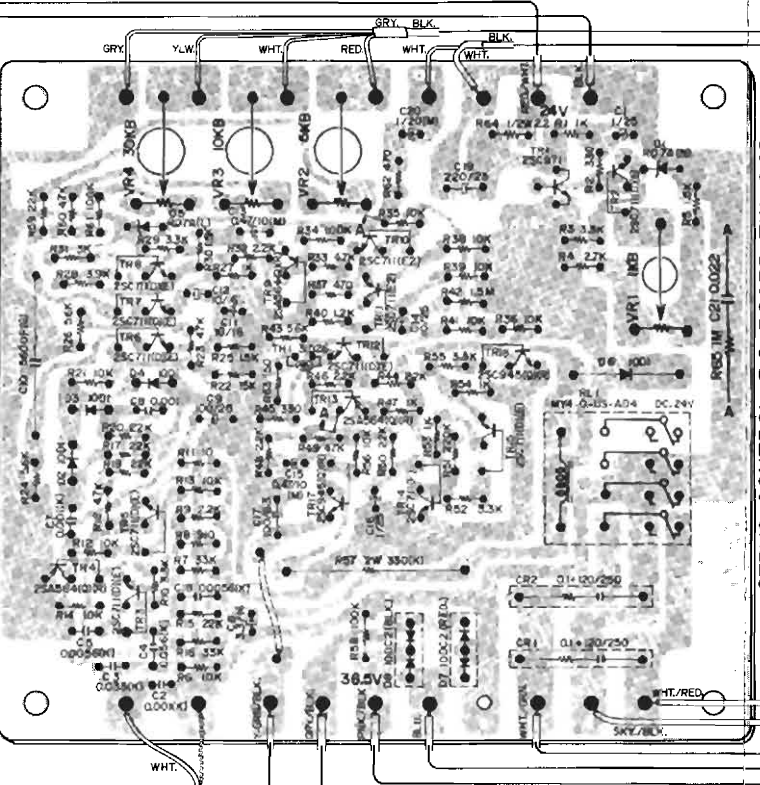

SERVO CONTROL P.C. BOARD TW-1049

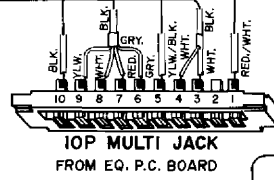

TOP MULTI JACK FROM EQ. P.C. BOARD

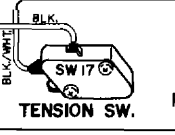
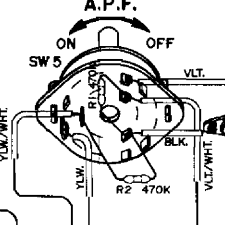
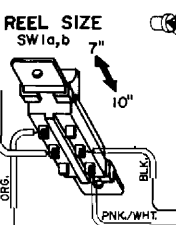
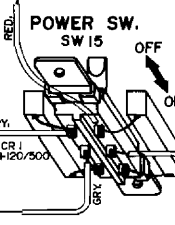

TENSION SW. RWD. SENSING POLE

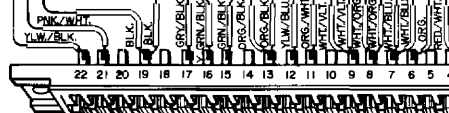

MULTI JACK 2

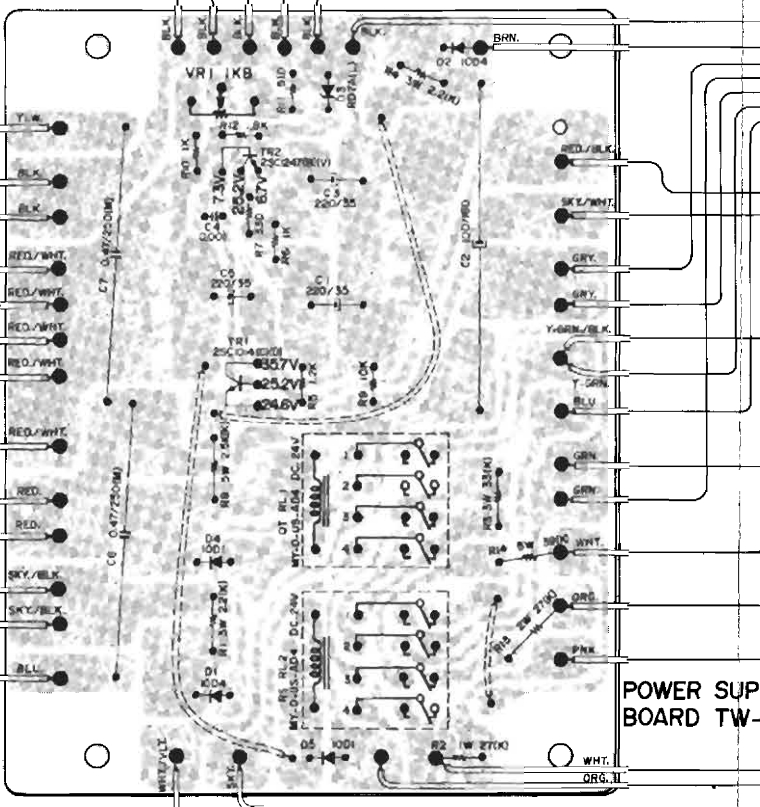

POWER SUPPLY P.C. BOARD TW-2018

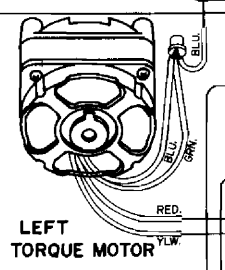

LEFT TORQUE MOTOR

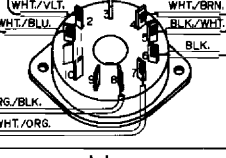
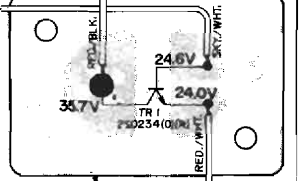
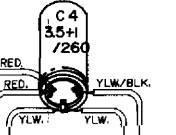
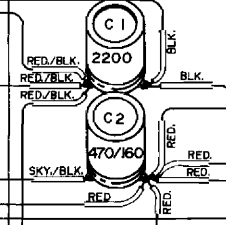

J1 REMO-CON JACK

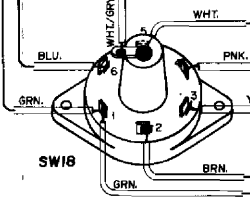

VOLTAGE SELECTOR & FUSE POST

GX-400D

LEFT REC. AMP. P.C. BOARD TW-5206

LEFT P.B. AMP. P.C. BOARD TW-5032

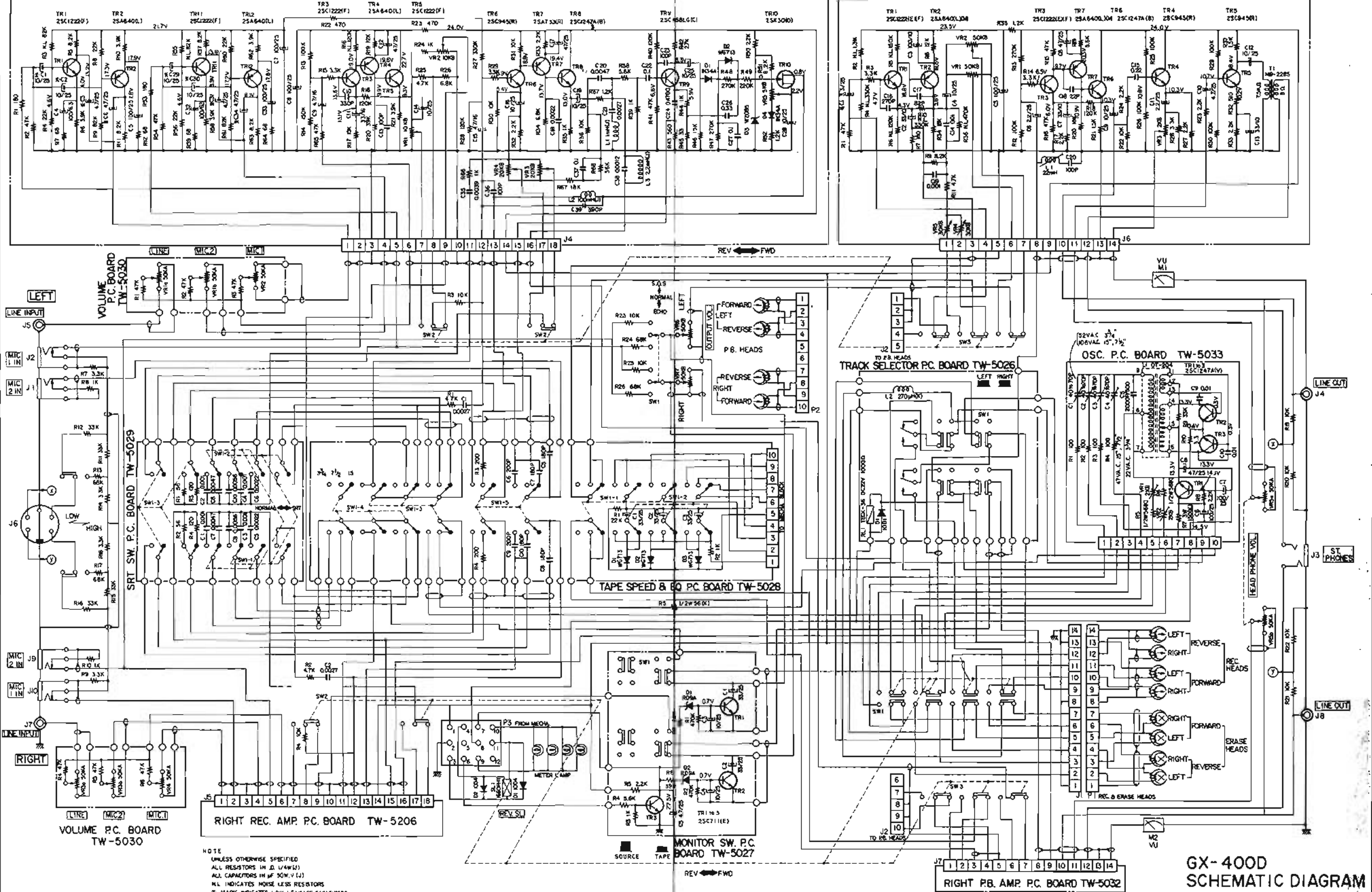

NOTE
 UNLESS OTHERWISE SPECIFIED
 ALL RESISTORS IN Ω, Ω/W/Ω(S)
 ALL CAPACITORS IN μF, 50WV (U)
 ML INDICATES NOISE LESS RESISTORS
 X MARK INDICATES LOW LEAKAGE CAPACITORS

GX-400D
 SCHEMATIC DIAGRAM
 No. 2-1 1461250A

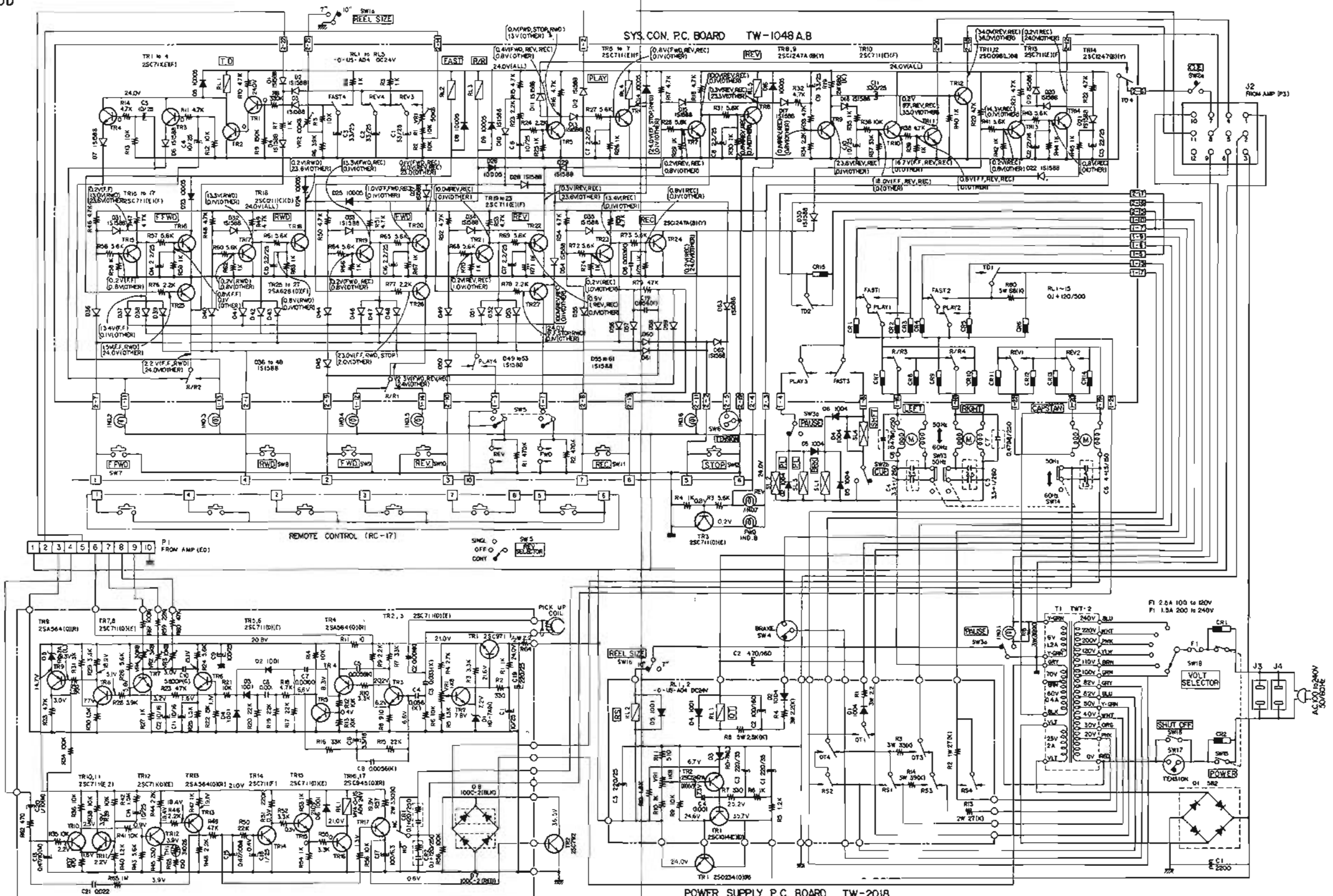

SERVO CONTROL P.C. BOARD TW-1049

POWER SUPPLY P.C. BOARD TW-2018

NOTE
 UNLESS OTHERWISE SPECIFIED
 ALL RESISTORS IN Ω (1/4W 1%)
 ALL CAPACITORS IN μF (50V V.C.I.)
 —□— MARK INDICATES SPARK QUENCHER
 0.1μF = 100Ω/500V

GX-400D·PRO

LEFT REC AMP. P.C. BOARD TW-5206

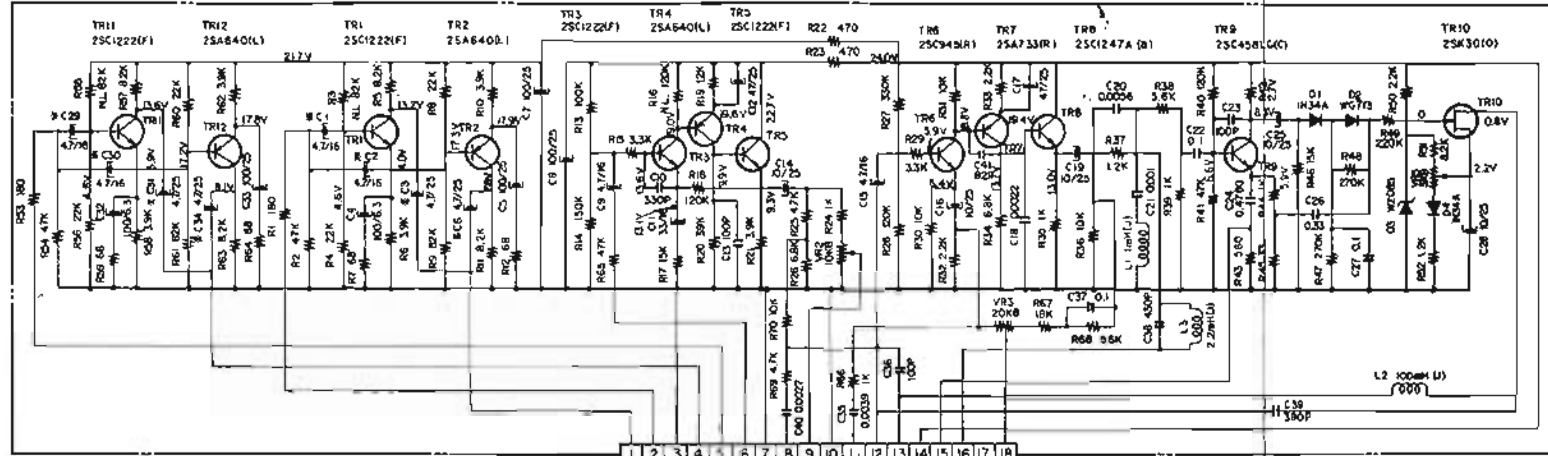

LEFT P8. AMP. P.C. BOARD TW-5032

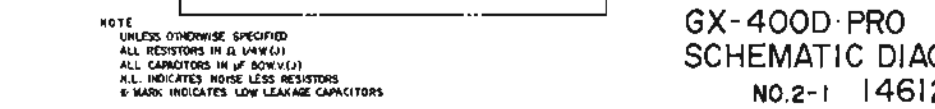
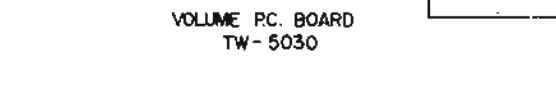
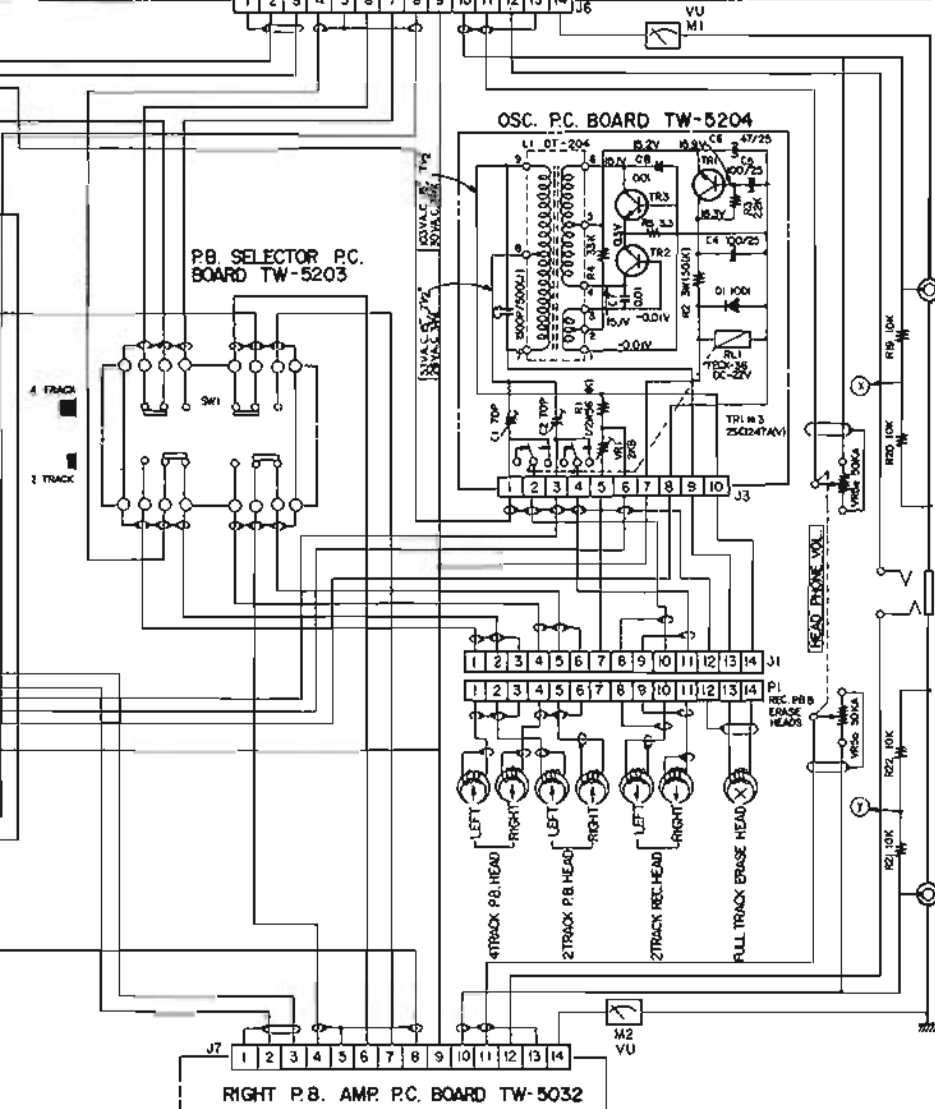
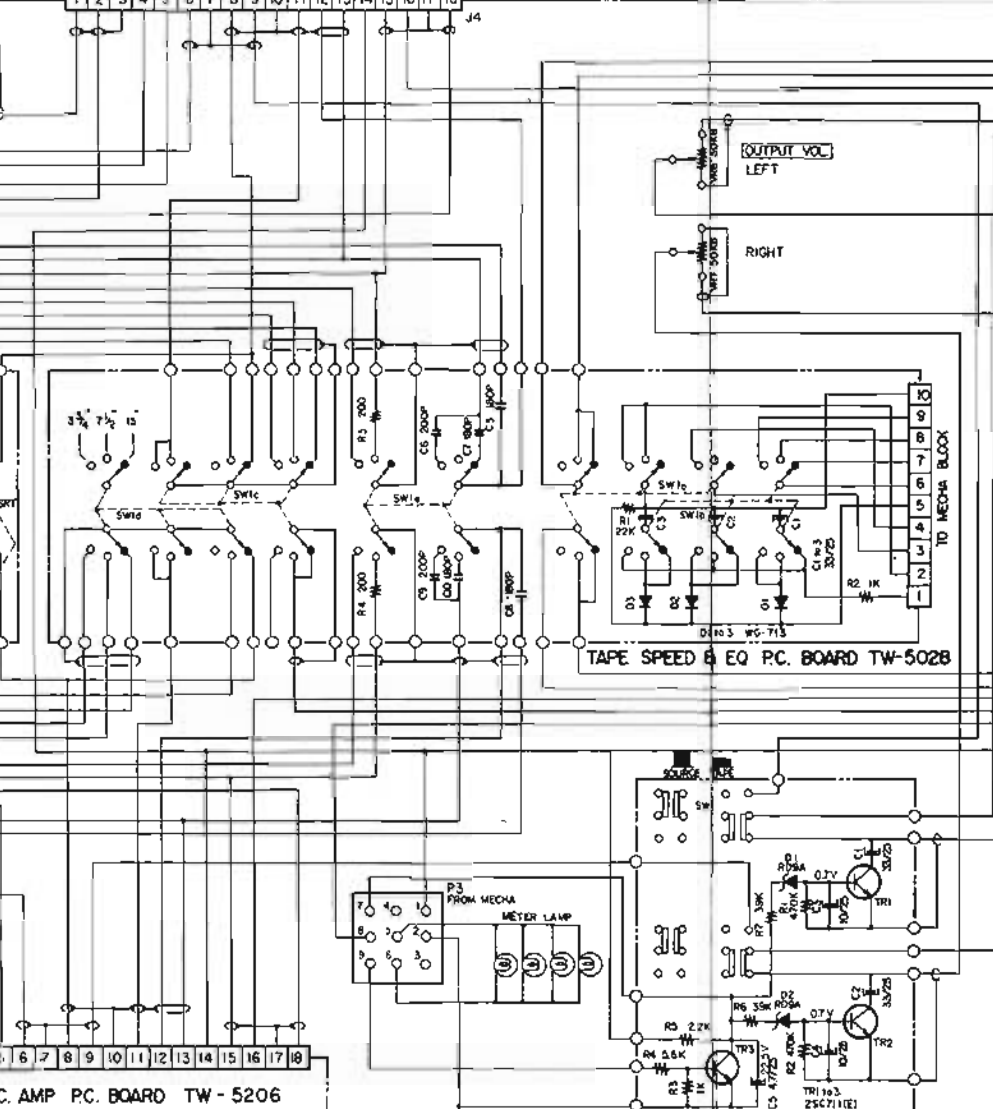
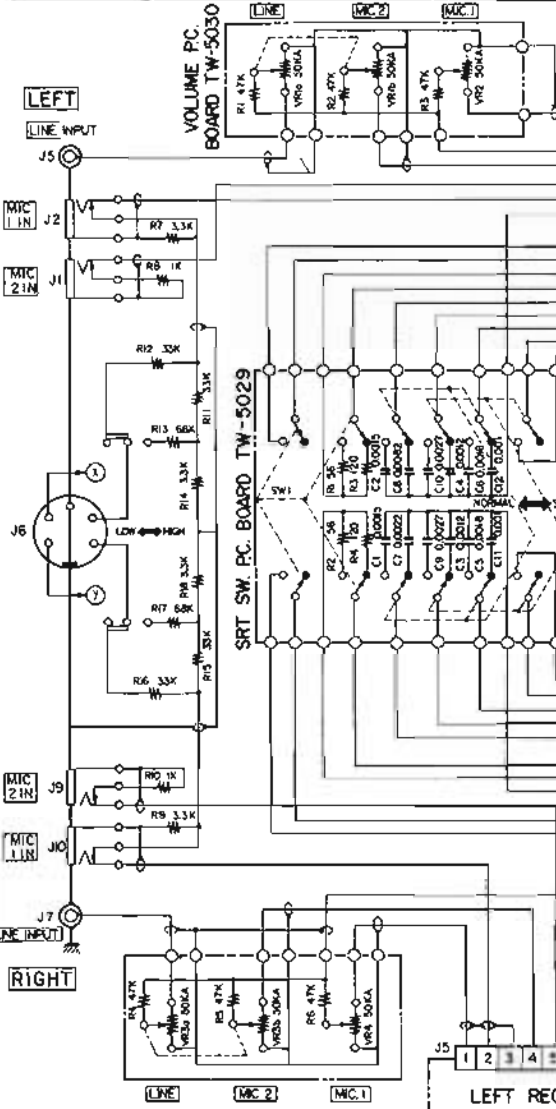
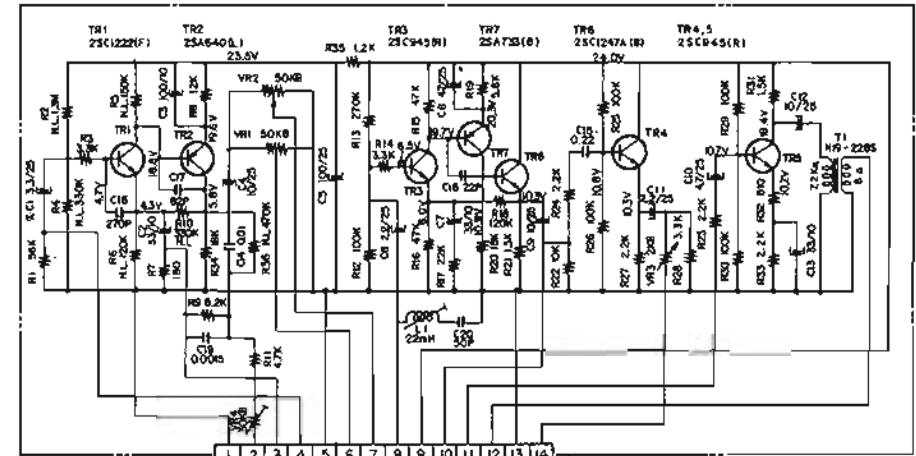

NOTE
UNLESS OTHERWISE SPECIFIED
ALL RESISTORS IN Ω UNLESS (Ω)
ALL CAPACITORS IN µF UNLESS (µ)
N.L. INDICATES NOISE LESS RESISTORS
& MARK INDICATES LOW LEAKAGE CAPACITORS

GX-400D·PRO
SCHEMATIC DIAGRAM
NO.2-1 1461252A
2C

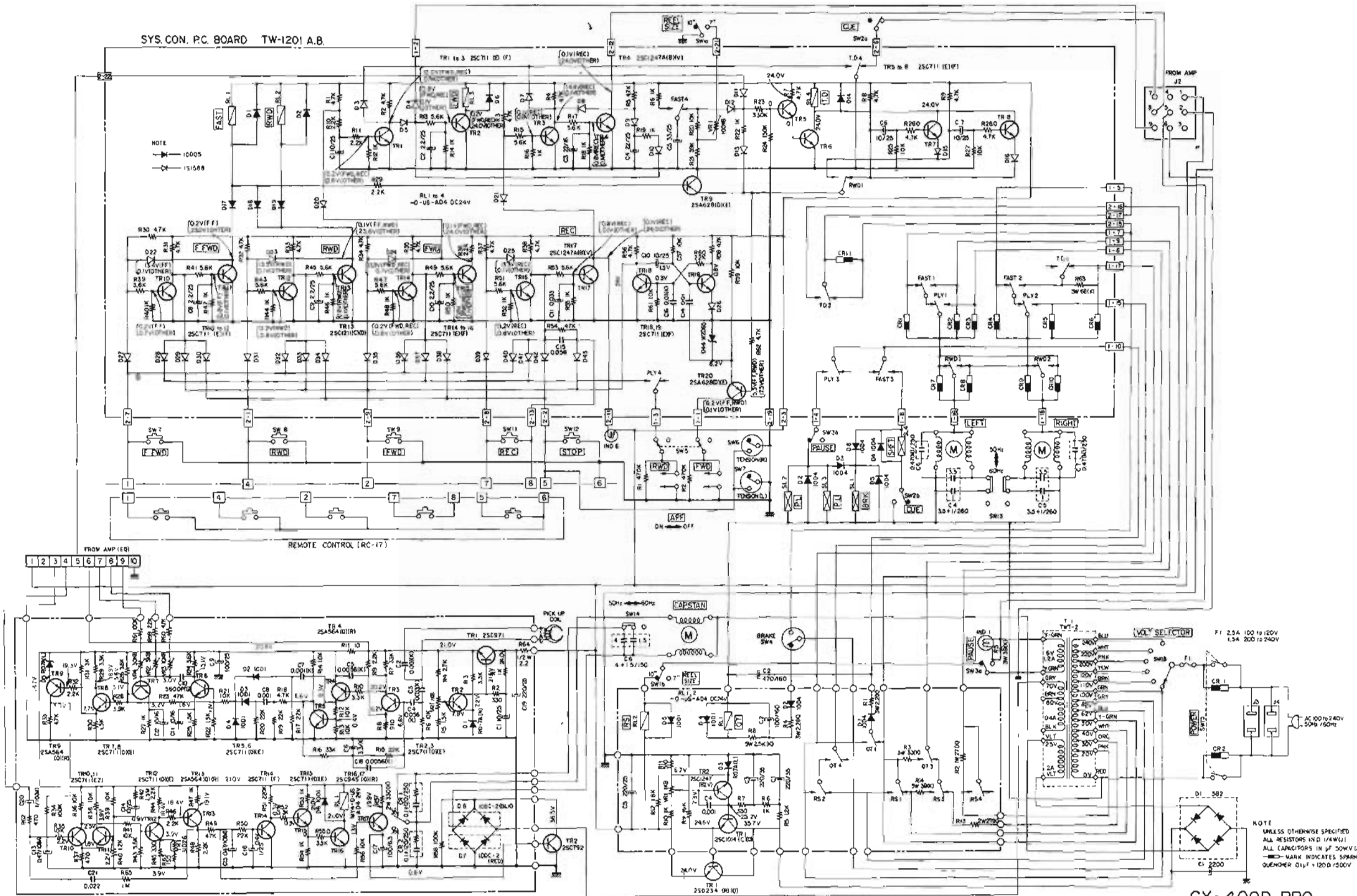

NOTE
 UNLESS OTHERWISE SPECIFIED
 ALL RESISTORS IN Ω (4W/1/1)
 ALL CAPACITORS IN μF (50WV/10)
 — MARK INDICATES 50W/10
 QUENCHER 0.1μF 120V/500V

GX-400D-PRO
 SCHEMATIC DIAGRAM
 NO.2-2 1461253A_{2c}

A AKAI ELECTRIC CO., LTD.
AKAI TRADING CO., LTD.

(P.O. BOX 21, Tokyo International Airport, Japan)
12-14, 2-chome, Higashi-Kojiya, Ohta-ku, Tokyo, Japan

TELEPHONE: TOKYO (742) 5111

CABLE: HIFIAKAI TOKYO TELEEX: J26261

Printed No. 1462062 Printed in Japan Price \$15.00